

## User Replaceable Parts

### FX-880+

Reference number	User replaceable part	Parts price list name	Part number
107	Front cover	Cover, front assembly	1090495
108	Knob	Knob	1039337
120	Logo plate	Logo plate	1090266
115	Optional interface cover	Upper connector cover	1037223
106	Paper guide	Sheet guide assembly, rear	1040399
135	Paper guide support frame	Support frame, sheet guide	1039332
585	Paper thickness lever cap	Lever cap	1039412
104	Printer cover	Cover assembly, printer	1066760
	Ribbon cartridge	Ribbon cartridge	8750
541	Tractor	Tractor assembly	1040231
105	Rear wing	Wing	1039434
101	Rubber foot	Foot	1004605

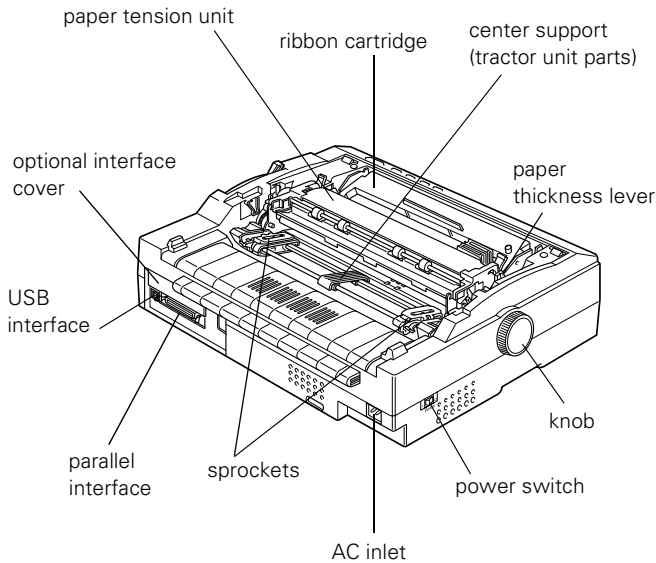

### FX-1180+

Reference number	User replaceable part	Parts price list name	Part number
TBD	Front cover	Cover, front	TBD
TBD	Knob	Knob	TBD
TBD	Logo plate	Logo plate	TBD
TBD	Optional interface cover	Upper connector cover	TBD
TBD	Paper guide	Sheet guide assembly, rear	TBD
TBD	Paper guide support frame	Support frame, sheet guide	TBD
TBD	Paper thickness lever cap	Cap cover	TBD
TBD	Printer cover	Cover assembly, printer	TBD
	Ribbon cartridge	Ribbon cartridge	8755
TBD	Tractor	Tractor assembly	TBD

## Options

### Paper Handling Options

**High-capacity cut-sheet feeder (C806381 for FX-880+, C806401 for FX-1180+)**

Feeds up to 150 sheets of paper or 25 plain bond envelopes into the printer without reloading. You can load single sheets, single-sheet multi-part forms, or envelopes.

**Single-bin cut-sheet feeder (C806371 for FX-880+, C806391 for FX-1180+)**

Feeds up to 50 sheets of paper into the printer without reloading. Load only ordinary single sheets in this feeder.

**Additional tractor unit (C800201 for FX-880+, C800211 for FX-1180+)**

Use the additional tractor in the pull position along with your standard tractor installed in the front or rear push position to improve paper handling and reduce the chance of paper jams. This setup is especially useful with continuous multi-part forms.

**Roll paper holder (8310)**

Allows you to use your printer with 8.5-inch roll paper like that used with telex machines.

**Front sheet guide (C814001 for FX-880+, C814011 for FX-1180+)**

Allows you to load single sheets and carbonless single-sheet multi-part forms of up to 6 parts.

**Front paper guide (C814021 for FX-880+, C814031 for FX-1180+)**

Allows you to load single sheets and carbonless single-sheet multi-part forms of up to 6 parts without removing the tractor from the front push position.

### Optional Interface Cards

You can install an optional interface card to supplement your printer's built-in USB and parallel interfaces and provide added network compatibility. The EPSON interface cards in the table below are compatible with your printer.

Card type	Model number
Serial interface	C823051
32 KB intelligent serial interface	C823071
Coax interface	C823141
Twinax interface	C823151
IEEE-1284 parallel interface	C823452
EpsonNet 10/100 Base TX Internal Print Server	C823912



Other network interface cards (such as the C823622A, C823632A, and C823642A) are also supported on this printer. Check with EPSON for more information.

### System Compatibility

The printer supports the following versions of Microsoft Windows:

- ❑ Windows 3.1, 95, and NT: parallel interface only.
- ❑ Windows 98, Me, 2000: parallel and USB interfaces.

## Printer Specifications

### Mechanical

Printing method	9-pin impact dot matrix
Printing speed	Ultra speed draft 494 cps at 10 cpi 564 cps at 12 cpi High-speed draft 440 cps at 10 cpi 493 cps at 12 cpi Draft 330 cps at 10 cpi 396 cps at 12 cpi Near letter quality 82.5 cps at 10 cpi 99 cps at 12 cpi
Printing direction	Bidirectional logic seeking for text and graphics printing. Unidirectional text or graphics printing can be selected using software commands.
Line spacing	1/6-inch or programmable in 1/432-inch increments
Printable columns	FX-880+: 80 columns (at 10 cpi) FX-1180+: 136 columns (at 10 cpi)
Resolution	240 × 144 dpi (near letter quality)
Paper feed methods	Friction (front, rear) Push tractor (front, rear) Pull tractor (front, bottom, rear) Push and pull tractor (additional tractor is required) (front, rear) Cut-sheet feeders (optional) Roll paper holder (optional)
Paper feed speed	Continuous 5 inches (127 mm)/second Normal mode 62 msec/line at 1/6-inch line spacing

**Paper capacity**

Single-bin cut-sheet feeder  
up to 50 sheets of 22 lb (82 g/m<sup>2</sup>) paper

*Note*  The total thickness of the paper stack can be up to 0.20 inch (5 mm).

High-capacity cut-sheet feeder  
up to 150 sheets of 22 lb (82 g/m<sup>2</sup>) paper  
up to 25 plain or bond envelopes  
up to 30 airmail envelopes

*Note*  The total thickness of the paper stack can be up to 0.59 inch (15 mm).

**Reliability**

Total print volume  
26 million lines (except print head)

MTBF  
12,500 POH (25% duty)

Print head life  
400 million strokes per wire;  
approximately 200 million characters  
(Draft, 10 cpi, 14 dots/character)

**Acoustic noise**  
Approx. 53 dB (A) (ISO 7779 pattern)

**Dimensions and weight**

Height  
6.1 inches (154 mm)

Width  
FX-880+: 16.3 inches (415 mm)  
FX-1180+: 23.2 inches (590 mm)

Depth  
13.8 inches (350 mm)

Weight  
FX-880+: 16.8 lb (7.6 kg)  
FX-1180+: 21.2 lb (9.6 kg)

**Ribbon**

Black ribbon cartridge  
FX-880+: 8750  
FX-1180+: 8755

Ribbon life  
approximately 5 million characters  
(Draft, 10 cpi, 14 dots/character)

**Electronic**

**Interfaces** One standard bidirectional 8-bit parallel interface with IEEE 1284 nibble mode support, one USB (ver 1.1) interface, and one optional Type B interface slot

**Buffer** 96KB

**Built-in fonts** Bitmap fonts:  
EPSON Draft 10, 12, 15 cpi  
EPSON Roman 10, 12, 15 cpi, proportional  
EPSON Sans Serif 10, 12, 15 cpi, proportional

Bar code fonts:  
EAN-13, EAN-8, Interleaved 2 of 5, UPC-A, UPC-E, Code 39, Code 128, POSTNET

**Character tables** Standard version: 13 character tables  
NLSP version: 36 character tables

**Character sets** 13 international character sets

**Electrical**

	120 V	220 to 240 V	Universal (UPS)
<b>Rated voltage range</b>	120 V	220 to 240 V	100 to 120 V/ 220 to 240 V
<b>Input voltage range</b>	103.5 to 132 V	198 to 264 V	90 to 132 V/ 198 to 264 V
<b>Rated frequency range</b>	50 to 60 Hz		
<b>Input frequency range</b>	49.5 to 60.5 Hz		
<b>Rated current</b>	0.7 A (maximum 2.1 A depending on the character type)	0.4 A (maximum 1.2 A depending on the character type)	0.8 A (maximum 2.4 A depending on the character type)/ 0.5 A (maximum 1.2 A depending on the character type)
<b>Power consumption</b>	Approx. 40W (ISO/IEC 10561 letter pattern)		Approx. 42 W (ISO/IEC 10561 letter pattern)

## Environmental

	Temperature	Humidity (without condensation)
<b>Operation (plain paper)</b>	41 to 95 °F (5 to 35 °C)	10 to 80% RH
<b>Operation (recycled paper, envelopes, labels or roll paper)</b>	59 to 77 °F (15 to 25 °C)	30 to 60% RH
<b>Storage</b>	-22 to 140 °F (-30 to 60 °C)	0 to 85% RH

## Paper



Use recycled paper, multipart paper, labels, envelopes, and roll paper only under normal temperature and humidity conditions, as follows:

Temperature 59 to 77 °F (15 to 25 °C)  
Humidity 30 to 60% RH

Do not load paper that has been folded or is damaged, wrinkled, or curled.

### Single sheets, front or rear entry

	Minimum	Maximum	
<b>Width*</b> (inch) (mm)	3.9 100	FX-880+: 10.1 257	FX-1180+: 16.5 420
<b>Length**</b> (inch) (mm)	3.9 100	14.3 364	
<b>Thickness***</b> (inch) (mm)	0.0025 0.065	0.0055 0.14	
<b>Weight</b> (lb) (g/m <sup>2</sup> )	14 52	24 90	
<b>Quality</b>	Plain paper and recycled paper		

\* 7.2 to 8.5 inches (182 to 216 mm) for the optional cut-sheet feeder for FX-880+.  
7.2 to 16.5 inches (182 to 420 mm) for the optional cut-sheet feeder for FX-1180+.

\*\* 8.3 to 14.3 inches (210 to 364 mm) for the optional cut-sheet feeder.

\*\*\*0.0028 to 0.0055 inch (0.07 to 0.14 mm) for the optional cut-sheet feeder.

### Single-sheet multipart forms (for the optional front sheet or front paper guide only):

	Minimum	Maximum	
<b>Width</b> (inch) (mm)	3.9 100	FX-880+: 10.1 257	FX-1180+: 16.5 420
<b>Length</b> (inch) (mm)	3.9 100	14.3 364	
<b>Copies</b>	1 original + 5 copies		
<b>Total thickness</b> (inch) (mm)	0.0047 0.12	0.018 0.46	
<b>Weight per sheet of multipart</b> (lb) (g/m <sup>2</sup> )	12 40	15 58	
<b>Quality</b>	Carbonless multipart forms with a line of glue at the top or one side of the form		

### Continuous paper (ordinary and multipart):

	Minimum	Maximum	
<b>Width</b> (inch) (mm)	4.0 101.6	FX-880+: 10.0 254.0	FX-1180+: 16.0 406.4
<b>Length, one page</b> (inch) (mm)	4.0 101.6	22.0 558.8	
<b>Copies</b>	1 original + 5 copies		
<b>Total thickness</b> (inch) (mm)	0.0025 0.065	0.018 0.46	
<b>Weight, ordinary paper</b> (lb) (g/m <sup>2</sup> )	14 52	22 82	
<b>Weight per sheet of multipart</b> (lb) (g/m <sup>2</sup> )	12 40	15 58	
<b>Quality</b>	Plain paper, recycled paper, and carbonless multipart forms with point gluing or paper stapling on both sides		



Do not load thick paper, such as multipart forms with five or six parts, in the rear slot.

The ratio of the cut/uncut length at the perforation should be between 3:1 and 5:1.

The thickness of the perforation part when extended should be 1 mm or less.

The perforation between pages should not extend all the way to the edges of the paper. Uncut length on the edges should be 1 mm or more.

The horizontal and vertical perforation cuts should not cross.

**Continuous labels (front and bottom entry only):**

*Note* Use only labels mounted on continuous backing sheets.

	Minimum	Maximum	
<b>Label size</b>	See the figure below.		
<b>Width, backing sheet</b> (inch) (mm)	4.0 101.6	FX-880+: 10.0 254.0	FX-1180+: 16.0 406.4
<b>Length, backing sheet</b> (inch) (mm)	4.0 101.6	22.0 558.8	
<b>Thickness, backing sheet</b> (inch) (mm)	0.0028 0.07	0.0035 0.09	
<b>Total thickness</b> (inch) (mm)	0.0063 0.16	0.0075 0.19	
<b>Label weight</b> (lb) (g/m <sup>2</sup> )	17 64		
<b>Quality</b>	Plain paper		

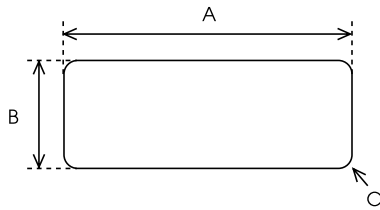

- A 2.5 inches (63.5 mm) min.
- B 15/16 inch (23.8 mm) min.
- C Corner radius = 0.1 inch (2.5 mm) min.

**Envelopes (rear entry only):**

		Minimum	Maximum
<b>Envelope size (No. 6)</b>	<b>Width</b> (inch) (mm)	6.5 165	
	<b>Length</b> (inch) (mm)	3.6 92	
<b>Envelope size (No. 10)</b>	<b>Width</b> (inch) (mm)	9.5 241	
	<b>Length</b> (inch) (mm)	4.1 105	
<b>Total thickness</b> (inch) (mm)		0.0063 0.16	0.0205 0.52
	Differences in thickness within the printable area must be less than 0.0098 inch (0.25 mm).		
<b>Weight</b> (lb) (g/m <sup>2</sup> )		12 45	24 90
	<b>Quality</b>	Bond envelopes, plain envelopes, and airmail envelopes without glue on the flap	

**Roll paper (rear entry with optional roll paper holder only):**

	Minimum	Maximum
<b>Width</b> (inch) (mm)	8.5 216	
<b>Length</b> (inch) (mm)	—	
<b>Thickness</b> (inch) (mm)	0.0028 0.07	0.0035 0.09
<b>Weight</b> (lb) (g/m <sup>2</sup> )	14 52	22 82
<b>Quality</b>	Plain paper	

## Printable Area

### Single sheets

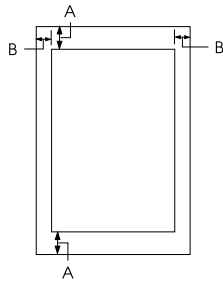

A The minimum top and bottom margins are 0.17 inch (4.2 mm).

B FX-880+:  
The minimum left and right margins are 0.12 inch (3 mm).  
The maximum printable width is 8.0 inches (203.2 mm).

FX-1180+:  
The minimum left and right margins are 0.12 inch (3 mm).  
The maximum printable width is 13.6 inches (345.4 mm).

### Continuous paper

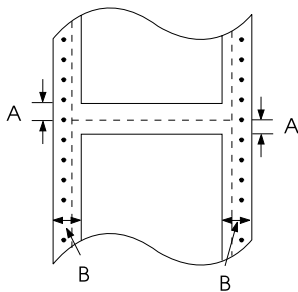

A The minimum top and bottom margins above and below the perforation are 0.17 inch (4.2 mm).

B FX-880+:  
The minimum left and right margins are 0.51 inch (13 mm).  
The maximum printable width is 8.0 inches (203.2 mm). For paper wider than 9.0 inches (229.2 mm), the side margins increase to match the width of the paper.

FX-1180+:  
The minimum left and right margins are 0.51 inch (13 mm).  
The maximum printable width is 13.60 inches (345.4 mm). For paper wider than 14.6 inches (371.4 mm), the side margins increase to match the width of the paper.

### Envelopes

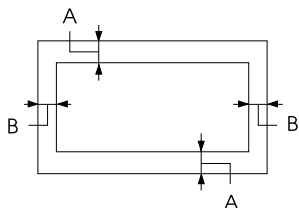

A The minimum top and bottom margins are 0.17 inch (4.2 mm).

B The minimum left and right margins are 0.12 inch (3 mm).

### Roll paper

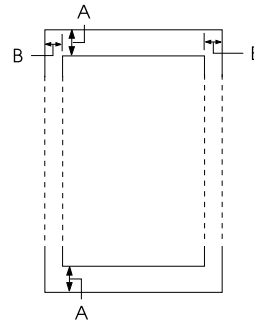

A The minimum top and bottom margins are 0.17 inch (4.2 mm).

B The minimum left and right margins are 0.12 inch (3 mm). The maximum printable width is 8.0 inches (203.2 mm).

## Standards and Approvals

### 120 V (US model)

#### Safety standards

UL 1950  
CSA C22.2 No. 950

EMI FCC part 15 subpart B class B  
CSA C108.8 class B

### 230 V (European model)

#### Safety standard

EN 60950

EMI EN 55022 (CISPR pub. 22) class B  
AS/NZS 3548 class B

### Universal (UPS) model

#### Safety standards

UL 1950  
CSA C22.2 No. 950  
EN 60950

EMI FCC part 15 subpart B class B  
CSA C108.8 class B  
EN 55022 (CISPR pub. 22) class B  
AS/NZS 3548 class B

## Control Panel Buttons and Lights

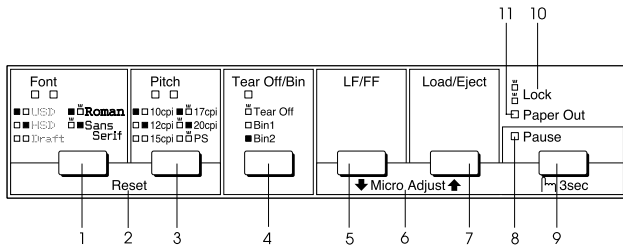

Button/Light	Function
1 Font button Font lights	Selects one of the fonts. Indicate which font is selected.
2 Reset	When you press both the Font and Pitch buttons simultaneously, the printer clears the buffer and restores its default settings.
3 Pitch button Pitch lights	Selects one of the pitch settings. Indicates which pitch is selected.
4 Tear Off/Bin button Tear Off/Bin light	Feeds continuous paper forward to the tear-off position. Feeds continuous paper backward from the tear-off position to the top-of-form position. Selects a cut-sheet feeder bin when the cut-sheet feeder is installed. Flashes when continuous paper is in the tear-off position. On when bin 1 of the optional cut-sheet feeder is selected. Off when bin 2 of the optional cut-sheet feeder is selected.
5 Lf/FF button	Feeds paper line by line when pressed quickly. Ejects a single sheet or advances continuous paper to the next top-of-form position when held down.
6 Micro Adjust	When you hold down the Pause button for three seconds, the printer enters Micro Adjust mode. In this mode, you can press the Lf/FF $\blacktriangledown$ and Load/Eject $\blacktriangle$ buttons to adjust the top-of-form or tear-off position.
7 Load/Eject button	Loads a single sheet of paper. Ejects a single sheet of paper. Loads continuous paper from the standby position. Feeds continuous paper backward to the standby position if a sheet is loaded.
8 Pause light	On when the printer is paused. Flashes when the printer is in Micro Adjust mode.

- 9 Pause button  
Stops printing temporarily, and resumes printing when pressed again.  
When held down for three seconds, enters Micro Adjust mode. When pressed again, exits Micro Adjust mode.
- 10 Lock  
When Lock-out mode is on, the Paper Out and Pause lights flash if a locked button is pressed.
- 11 Paper Out light  
On when no paper is loaded in the selected paper source or paper is not loaded correctly.  
Flashes when paper has not been fully ejected or a paper jam has occurred.

## Power-on Functions

The table below summarizes the power-on functions available through the control panel. To perform the function on the right, hold down the button(s) on the left while you turn on the printer.

Control panel button	Function
Load/Eject	NLQ self test
Lf/FF	Draft self test
Font	Default setting mode
Load/Eject + Lf/FF	Data dump
Load/Eject + Lf/FF + Pause	EEPROM reset
Pause	Bidirectional adjustment mode
Load/Eject + Pause	Control panel Lock-out mode (on/off)
Lf/FF + Pause	Default settings for control panel Lock-out mode
Font + Pitch	Quiet mode
Pitch + Pause	Copy mode
Font + Tear Off/Bin	Default setting, simple mode
Tear Off/Bin + Pause	Okidata ML 320T mode (FX-880+ only)

## Error Indicators

If the printer stops working and one or more control panel lights are on or flashing, or the printer beeps, use the following table to diagnose and fix the problem.

Light status	Beep pattern	Problem
		Solution
<input type="checkbox"/> Paper Out <input type="checkbox"/> Pause	●●●	No paper is loaded in the selected paper source.  Load paper in the printer or select a different paper source; the Paper Out light goes off. Then press the Pause button; the Pause light goes off and the printer starts printing.
		The paper is not loaded correctly.  Remove paper and reload it correctly.
<input type="checkbox"/> Pause	●●●	The paper release lever is set to the wrong position.  Set the paper release lever to the position for the paper source you want to use. See page 10.  If paper from another paper source is currently in the paper path, press the Load/Eject button to eject the paper; then move the paper release lever to the desired position.
<input type="checkbox"/> Paper Out <input type="checkbox"/> Pause	●●●	A single sheet of paper is not fully ejected.  Press the Load/Eject button to eject the sheet.
		Continuous paper is not fed to the standby position.  Tear off the printed page at the perforation; then press the Load/Eject button. The printer feeds the paper to the standby position.
	●●●	Paper is jammed in the printer.  To clear the paper jam, see page 13.
<input type="checkbox"/> Paper Out <input type="checkbox"/> Pause	—	The print head is overheated.  Wait a few minutes; the printer resumes printing automatically once the print head cools.
		The printer is in Micro Adjust mode.  Make the adjustments as described on page 10.
All lights flashing	●●●●●	An unknown or fatal printer error has occurred.  Turn off the printer and leave it off for several minutes; then turn on the printer again. If the error recurs, contact your dealer or EPSON.

= on     = flashing

●●● = three beeps, ●●●●● = five beeps

## Selecting a Font and Pitch

Usually, you use your application program to select the font and pitch you want to use in a document. However, you can select one of the printer's five fonts (in different pitches) with the buttons on the printer's control panel, as described below.



Settings you make in application programs usually override settings you make from the printer's control panel. For best results, use your application to select a font and make other settings.

The available pitch depends on the font you select. See the table below for more information.

Font	Pitch
USD	10, 12
HSD	10, 12, 15, 17, 20
Draft	10, 12, 15, 17, 20, PS
Roman	10, 12, 15, 17, 20, PS
Sans Serif	10, 12, 15, 17, 20, PS

1. Make sure that the printer is not printing. If it is, press the **Pause** button to stop printing.
2. Press the **Font** button until the two Font lights indicate the desired font as shown below.

Lights	Font
<input checked="" type="checkbox"/> <input type="checkbox"/>	USD
<input type="checkbox"/> <input checked="" type="checkbox"/>	HSD
<input type="checkbox"/> <input type="checkbox"/>	Draft
<input checked="" type="checkbox"/> <input type="checkbox"/>	Roman
<input type="checkbox"/> <input checked="" type="checkbox"/>	Sans Serif

= on     = off     = flashing

3. Press the **Pitch** button until the two Pitch lights indicate the desired pitch as shown below.

Lights	Pitch
<input checked="" type="checkbox"/> <input type="checkbox"/>	10 cpi
<input type="checkbox"/> <input checked="" type="checkbox"/>	12 cpi
<input type="checkbox"/> <input type="checkbox"/>	15 cpi
<input checked="" type="checkbox"/> <input type="checkbox"/>	17 cpi
<input type="checkbox"/> <input checked="" type="checkbox"/>	20 cpi
<input type="checkbox"/> <input type="checkbox"/>	PS

= on     = off     = flashing



## Selecting a Paper Source

Paper can be fed into the printer from the top, front, bottom, or rear. Select the paper source that best suits your current printing needs.

### Push Tractor Positions

There are two push tractor positions: front and rear. The tractor is installed in the rear push position when the printer is shipped.

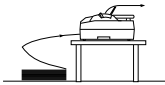
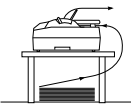
Tractor position	Description
 <p>front push</p>	<p>Load paper from the front slot.</p> <p>If you print on thick paper such as multipart forms, use the front paper slot because this paper path is almost straight. This reduces the chances of paper jams.</p>
 <p>rear push</p>	<p>Load paper from the rear slot.</p> <p>Do not load continuous paper with labels from the rear slot. Labels require a straight paper path; otherwise the labels may come off their backing sheets inside the printer and cause a paper jam.</p> <p>The rear slot is also not recommended when your multipart forms have 5 or 6 parts (1 original plus 4 or 5 copies), because paper might jam.</p>



### Pull Tractor Position

The pull tractor allows you to load continuous paper from the front, rear or bottom of the printer. However, you cannot use the tear-off feature when the tractor is in the pull position.

To use the tractor in the pull position, you can remove the tractor from the rear push position and reinstall it in the pull position, or you can purchase the optional pull tractor unit (C800201 for the FX-880+ or C800211 for the FX-1180+) and install it in the pull position.

 You need to remove the paper tension unit to use the tractor in the pull position.

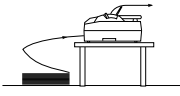
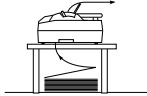
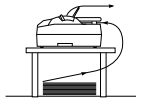
You can use the front, bottom, or rear paper slot with the pull tractor.

Paper slot	Description
 <p>front</p>	<p>If you print on thick paper such as multipart forms or continuous paper with labels, use the front paper slot because this paper path is nearly straight. This reduces the chances of paper jams.</p>
 <p>bottom</p>	<p>The bottom paper slot has the straightest paper path, so it is the best slot to use when printing on thick paper, such as multipart forms or continuous paper with labels.</p> <p>When loading paper from the bottom slot, be sure to use a printer stand with an opening large enough for the paper to feed through it without obstruction.</p>
 <p>rear</p>	<p>If the front or bottom paper slot is unavailable, you can also load ordinary continuous paper from the rear slot. Please note that loading paper from the rear slot results in a curved paper path, which may affect loading performance, so use the front or bottom slot whenever possible.</p> <p><b>Caution</b>  Do not load continuous paper with labels from the rear slot. The labels may come off the backing sheets inside the printer and cause a paper jam.</p>

## Setting the Paper Release Lever

Set the paper release lever to indicate the paper source you want to use, as described in the table below.

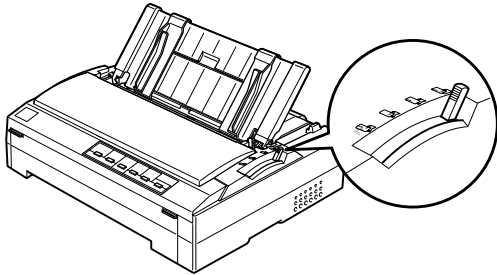

Lever position	Description
	Single-sheet position For loading single-sheet paper from the top or front slot.
	Front push tractor position For loading continuous paper with the tractor installed in the front push position or when using the front push and pull tractors in combination.
	Rear push tractor position For loading continuous paper with the tractor installed in the rear push position or when using the rear push and pull tractors in combination.
	Pull tractor position For loading continuous paper from the tractor installed on top of the printer in the pull position. You can load paper in the front, rear, or bottom slot.

## Adjusting the Paper-Thickness Setting

Set the paper-thickness setting for the type of paper you are using.

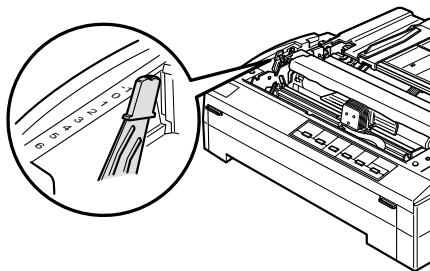

Paper type	Lever position
Ordinary paper	0 or 1 (single sheets) 0 (continuous paper)
Thin paper	-1 or 0
Carbonless multipart forms with: 2 parts (original + 1 copy) 3 parts (original + 2 copies) 4 parts (original + 3 copies) 5 parts (original + 4 copies) 6 parts (original + 5 copies)	1 2 3 4 5
Continuous paper with labels	2
Envelopes	2 to 6

**Note** When the temperature is 41°F (5°C) or less, set the paper-thickness lever one position lower to improve print quality. When the temperature is 95°F (35°C) or more, set the paper-thickness lever one position higher to improve print quality.

## Using the Micro Adjust Function

The Micro Adjust function allows you to move the paper forward or backward in 1/216-inch (0.118 mm) increments to adjust the tear-off and top-of-form positions.



### Adjusting the tear-off position

If your paper's perforation is not aligned with the tear-off edge, you can use the Micro Adjust function to move the perforation to the tear-off position. Your tear-off position setting remains in effect until you change it, even if you turn off the printer.

**Caution** Never use the knob to adjust the tear-off position; this may damage the printer or cause it to lose the tear-off position.

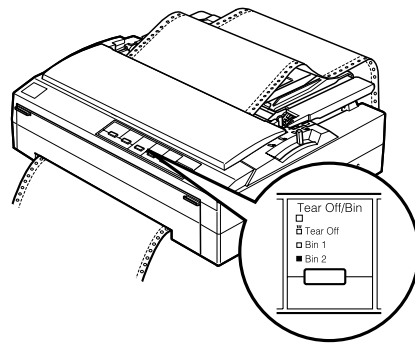
1. Make sure the Tear Off/Bin light is flashing (the paper is at the current tear-off position). You may need to press the Tear Off/Bin button to advance the paper to the tear-off position.



2. Hold down the **Pause** button for about three seconds. The Pause light begins flashing and the printer enters Micro Adjust mode.
3. Press **LF/FF**  to feed paper backward, or **Load/Eject**  to feed paper forward, until the paper perforation is aligned with the tear-off edge of the printer cover.

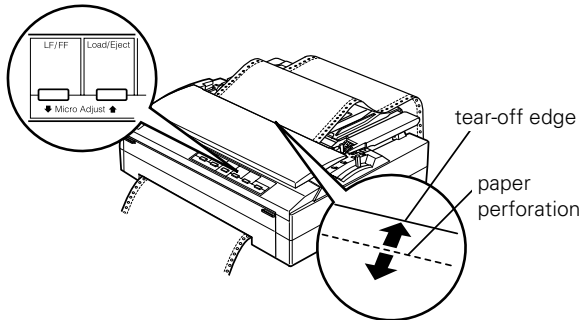

**Note**  The printer has a minimum and a maximum tear-off position. If you try to adjust the tear-off position beyond these limits, the printer beeps and stops moving the paper.

4. Tear off the printed pages.
5. Press the **Pause** button to turn off Micro Adjust mode.



When you resume printing, the printer automatically feeds the paper back to the top-of-form position and begins printing.

### Adjusting the top-of-form position

The top-of-form position is the position on the page where the printer starts printing. If your printing appears too high or low on the page, you can use the Micro Adjust function to adjust the top-of-form position, as described below. Your top-of-form position setting remains in effect until you change it, even if you turn off the printer.

**Caution**  Never use the knob to adjust the top-of-form position; this may damage the printer or cause it to lose the top-of-form position.

1. Make sure the printer is turned on.
2. Load paper. (If the tractor is in a push position, press the **Load/Eject** button to advance continuous paper to the current top-of-form position.) If necessary, lift up the printer cover so you can see the paper position.
3. Hold down the **Pause** button for three seconds. The Pause light flashes and the printer enters Micro Adjust mode.

4. Press the **LF/FF**  button to move the top-of-form position up on the page, or press the **Load/Eject**  button to move the top-of-form position down on the page.

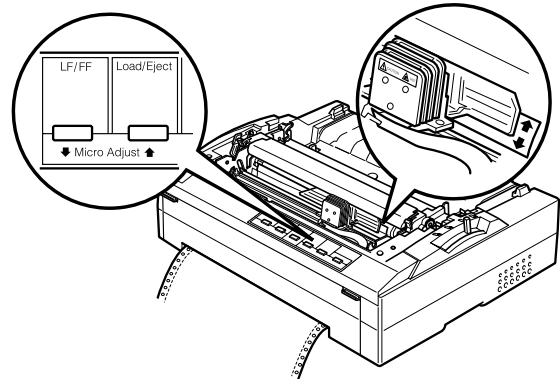

5. Press the **Pause** button to exit Micro Adjust mode.

**Note**  The printer has a minimum and a maximum top-of-form position. If you try to adjust it beyond these limits, the printer beeps and stops moving the paper.

When the paper reaches the default top-of-form position, the printer beeps and stops moving the paper briefly. You can use this setting as a reference point when adjusting the position.

The top margin setting made in some software overrides the top-of-form position setting you make with the Micro Adjust function.

### Loading Special Papers

Follow the guidelines in this section when loading continuous multipart forms, single-sheet multipart forms, labels, and envelopes.

#### Continuous multipart forms

Except for setting the paper-thickness lever, you load continuous multipart forms the same way as ordinary continuous paper. Just keep the following in mind:

- ❑ Be sure your multipart forms do not exceed 0.018 inch (0.46 mm) in thickness.
- ❑ Do not load paper that is curled or has been folded.
- ❑ Thick paper, such as multipart forms with five or six parts, requires a straight paper path to avoid paper jams. Load thick paper in the front or bottom slots.

## Single-sheet multipart forms

To load single-sheet multipart forms, use the front paper entry slot with the optional front paper guide or front sheet guide installed.

Thick paper, such as multipart forms with five or six parts, requires a straight paper path to avoid paper jams. Make sure the forms do not exceed 0.018 inch (0.46 mm).

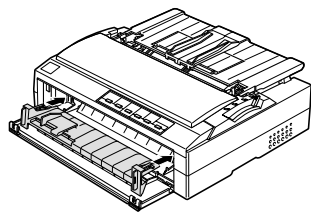

front paper guide

front sheet guide

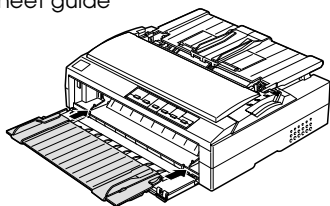

## Labels

When printing on labels, use only the type of labels that are mounted on continuous backing sheets with sprocket holes for use with a tractor feeder. Do not try to print on single sheets with labels because the printer may not feed labels on a shiny backing sheet properly.

Thick paper, such as continuous paper with labels, requires a straight or almost straight paper path. You can load labels in the front (push tractor or pull tractor) or bottom (pull tractor) paper slot; however, for best results, use the tractor in the pull position, and load paper in the front or bottom paper slot.

The loading procedure for continuous paper with labels is the same as that for ordinary continuous paper, except you must set the paper-thickness lever to 2 before printing. Keep the following in mind:

- ❑ It is best to load continuous paper with labels on the pull tractor. Do not load labels on the rear or front push tractor.
- ❑ Never feed labels backward using the Load/Eject or Tear Off/Bin button. When fed backward, labels can easily peel off the backing sheet and cause a paper jam.
- ❑ Because labels are sensitive to temperature and humidity, use them only under normal operating conditions:  
 Temperature: 59 to 77°F (15 to 25°C)  
 Humidity 30 to 60% RH
- ❑ Do not leave labels in the printer between jobs; they may curl around the platen and jam when you resume printing.
- ❑ Do not load continuous paper with labels from the rear paper slot. Because the rear paper path is curved, labels may come off their backing sheets inside the printer and cause a paper jam.
- ❑ Do not load paper that is curled or has been folded.

## Removing continuous paper with labels

To prevent labels from peeling off the backing sheet and jamming the printer, follow these steps to remove continuous paper with labels from the printer:

1. Tear off the fresh supply of continuous labels at the perforation nearest the paper entry slot.
2. Hold down the LF/FF button to eject the remaining labels from the printer.



**Caution** Never feed labels backward using the Load/Eject or Tear Off/Bin button. When fed backward, labels can easily come off the backing sheet and cause a paper jam.

## Envelopes

Before loading envelopes, set the paper-thickness lever to a position from 2 (for thin envelopes) to 6 (for thick envelopes).

You can feed envelopes one at a time using the paper guide, or you can load multiple envelopes using the optional high-capacity cut-sheet feeder (bin 1 of the double-bin cut-sheet feeder).

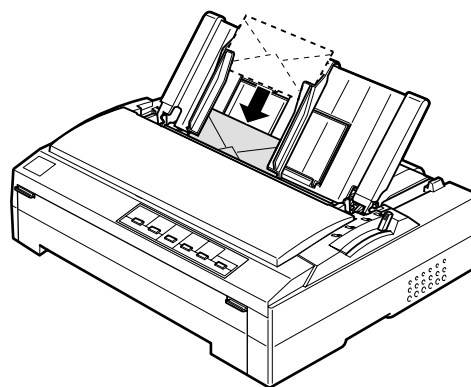

Be sure to place the envelope printable side down and insert the top edge of the envelope into the printer first.

The print head must not print past the left or right edge of the envelope or other thick paper. Make sure your application program prints entirely within the printable area of your envelope.

If you are using No. 6 envelopes, make sure the left edge guide is aligned with the arrow on the paper guide.

## Switching Paper Types

You can easily switch back and forth between printing on continuous paper with a push tractor and printing on single sheets without having to remove or reload the continuous paper.

### Switching to printing on single sheets

Follow the steps below to switch from printing on continuous paper from a push tractor to printing on single sheets.



If continuous labels are loaded in the printer, remove them before switching to single-sheet printing.

If the tractor is in the pull position, remove any continuous paper from it before switching to single-sheet printing.

1. If any printed pages remain in the printer, press the **Tear Off/Bin** button to advance the paper to the tear-off position. Then tear off the printed pages.



Make sure you tear off your printed document before you press the Load/Eject button in the next step. Reverse feeding several pages at a time may cause a paper jam.

2. Press the **Load/Eject** button to feed the continuous paper backward to the standby position. The paper is still attached to the push tractor but is no longer in the paper path.
3. Lower the continuous paper support on the paper guide until it clicks into place, then move the paper guide to the upright position.
4. Set the paper release lever to the single-sheet position.
5. Load single sheets.



### Switching to printing on continuous paper

Follow the steps below to switch from printing on single sheets to printing on continuous paper with a push tractor.



To switch from printing with the optional front sheet guide to printing with the front push tractor, you need to remove the front sheet guide.

1. If a single sheet remains in the printer, press the **Load/Eject** button to eject it.



Never use the knob to eject paper when the printer is on; this may damage the printer or cause it to lose the top-of-form position.

2. Make sure the tractor is installed in the front or rear push position and that continuous paper is loaded on it.

3. Set the paper release lever to the front or rear push position, depending on the tractor position you are using.

Your printer loads the continuous paper automatically when you begin printing.

## Clearing Paper Jams

Follow these steps to clear a paper jam:

1. Turn off the printer.
2. Open the printer cover.
3. If continuous paper is jammed in the printer, tear off the fresh supply at the perforation nearest the paper entry slot.
4. Turn the knob on the left side of the printer away from you to remove the paper in the printer. Remove any remaining pieces of paper.
5. If the paper is stuck where the printer ejects it, gently pull the paper out of the printer.



Use the knob on the left side of the printer to clear paper jams only when the printer is off. Otherwise, you may damage the printer or change the top-of-form or tear-off position.

6. Close the printer cover and turn on the printer. Make sure the **Paper Out** light is not flashing and the **Pause** light is off.

## Default Setting Mode

The default settings control many printer functions. While you can often set these functions through your software or printer driver, you may sometimes need to change a default setting from the printer's control panel using the default-setting mode.

The following table shows the options available for each printer setting. (Default settings appear in bold type.) Instructions for changing the settings follow the table.

Setting	Options
Skip over perforation	<b>Off</b> , On
Auto tear-off	<b>Off</b> , On
Auto line feed	<b>Off</b> , On
Print direction	<b>Bi-D</b> , Uni-D
Software	<b>ESC/P</b> , IBM PPDS (same as IBM 2380 Plus)
I/F (interface) mode	<b>Auto</b> , Parallel, USB, Option
Auto I/F (interface) wait time	<b>10 seconds</b> , 30 seconds
Manual feed wait time	1 second, <b>1.5 seconds</b> , 2 seconds, 3 seconds
Parallel I/F bidirectional mode	Off, <b>On</b>
Packet mode	Off, <b>Auto</b>
0 slash	<b>0</b> , Ø
Buzzer	Off, <b>On</b>
Auto CR (carriage return)*	<b>Off</b> , On
IBM character table*	<b>Table 2</b> , Table 1
Page length for front tractor	Length in inches: 3, 3.5, 4, 5.5, 6, 7, 8, 8.5, <b>11</b> , 70/6, 12, 14, 17
Page length for rear tractor	Length in inches: 3, 3.5, 4, 5.5, 6, 7, 8, 8.5, <b>11</b> , 70/6, 12, 14, 17
Character table	Standard model: italic, <b>PC 437</b> , PC 850, PC 860, PC 863, PC 865, PC 861, BRASCII, Abicomp, Roman 8, ISO Latin 1, PC858, ISO 8859-15 All other models: Italic, PC 437, PC 850, PC 437 Greek, PC 853, PC855, PC 852, PC 857, PC 866, PC 869, MAZOWIA, Code MJK, ISO 8859-7, Bulgaria, PC 774, Estonia, PC 866 LAT., ISO 8859-2, PC 866 UKR, PC-APTEC, PC-771, PC-AR864, PC 708, PC 720
International character set for italic table**	<b>Italic U.S.A.</b> , Italic France, Italic Germany, Italic U.K., Italic Denmark 1, Italic Sweden, Italic Italy, Italic Spain 1

\* This setting is available only in IBM PPDS emulation mode.

\*\* The options available for this setting vary depending on the country.

## Changing default settings

Follow the steps below to enter the default-setting mode and change the printer's default settings.



To print the language selection and default-setting mode instructions, you need three sheets of A4 or letter size single-sheet paper or three pages of continuous paper that is at least 11 inches (279 mm) long and 8.3 inches (210 mm) wide.

1. If you use single sheets, you need to load a new sheet of paper each time the printer ejects a printed sheet from the paper guide.
2. Make sure paper is loaded and the printer is turned off.
3. Turn on the printer while holding down the **Font** button. The printer enters the default-setting mode and prints the language selection instructions (one page).



If you want the instructions in English, there is a faster way to enter default setting mode which skips printing the language instruction sheet. Hold down the Tear Off button instead of the Font button while you turn on the printer.

4. Press the **Font** button until the Font and Pitch lights indicate the language you want, as described in the language selection instructions.
5. Press the **Tear Off/Bin** button to print the current default settings and instructions in the language you selected.
6. Follow the printed instructions to change the printer's default settings from the control panel.
7. When you finish making settings, turn off the printer to exit the default-setting mode.



You may exit the default-setting mode by turning off the printer at any time. Any settings you have made remain in effect until you change them again.

## Locking the Control Panel Buttons

You can restrict the use of buttons on the control panel using Lock-out mode. In the default Lock-out mode, you can use only the **Pause**, **Load/Eject** and **Tear off** buttons. If you want to change which functions are locked, see "Changing the Lock-out mode setting" below.

### Turning Lock-out mode on and off

1. Make sure the printer is turned off.
2. Turn on the printer while holding down the **Load/Eject** and **Pause** buttons. The printer beeps twice, indicating that the Lock-out mode has been turned on.

When the Lock-out mode is on, the Pause and Paper Out lights flash simultaneously when any locked button is pushed.

To turn Lock-out mode off, repeat steps 1 and 2. The printer beeps once, indicating that the Lock-out mode has been turned off.

### Changing the Lock-out mode setting

You can select which printer functions you want to be locked while Lock-out mode is on. Follow these steps:

1. Make sure paper is loaded and the printer is turned off.
2. Turn on the printer while holding down the LF/FF and Pause buttons. The printer enters the Lock-out setting mode and prints the instructions. (You'll need three sheets of A4 or letter size single-sheet paper or three pages of continuous paper that is at least 11 inches [279 mm] long and 8.3 inches [210 mm] wide.)
3. Follow the instructions to change the settings as desired.
4. Turn off the printer.

See the instructions above to turn on Lock-out mode after you change the Lock-out mode setting.

### Emulating the Okidata Microline 320 Turbo

If you have the EPSON FX-880+, you can make it work like the Okidata® Microline® 320 Turbo by turning the printer on in a different mode. In this mode, the printer emulates Okidata functions, including the following. Default settings are bold.

Feature	EPSON FX-880+ in Okidata mode	Okidata ML320 Turbo
Software emulation	<b>IBM® PPDS</b> , EPSON ESC/P®, Oki ML 320T	IBM ProPrinter III, EPSON ESC/P, Oki ML 320T
Printable area		
Top margin	22 mm	22 mm *
Bottom margin	<b>24 mm</b>	24 mm *
Line spacing (lines per inch)	<b>6 LPI</b> , 8 LPI	6 LPI, 8 LPI
Paper out override	<b>Off</b> , On	Off, On

\* As measured by EPSON.

 If you want to use your printer in Okidata mode, do not install the Windows driver that came with your FX-880+. If you have been using an Okidata driver, you can continue to use it with your FX-880+ in Okidata mode.

To enter Okidata mode, make sure the printer is turned off. Then hold down the Tear Off/Bin and Pause buttons while you turn on the printer. The printer beeps once. Now turn the printer off, wait 5 seconds, and turn it back on (with just the power switch) to begin using it in Okidata mode.

The printer remains in Okidata mode until you repeat the above procedure. To return to FX-880+ mode, hold down the Tear Off/Bin and Pause buttons while you turn on the printer. The printer beeps twice. Turn it off, wait 5 seconds, and then turn it back on to begin using the printer in FX-880+ mode.

 You can print the default settings for the printer when it is in Okidata mode to check the current settings and change them if necessary. See "Changing default settings" on page 14.

### Aligning Vertical Lines in Your Printout

If you notice that the vertical lines in your printout are not properly aligned, you can use the printer's bidirectional adjustment mode to correct this problem. During bidirectional adjustment, the printer prints three sheets of alignment patterns, labeled High Speed Draft, Draft, and NLQ (near letter quality). You select the best alignment pattern from each sheet.

To print the instruction sheet and alignment patterns, you need five single sheets or five pages of continuous paper of at least the following sizes:

Paper type	FX-880+	FX-1180+
Continuous paper (including perforated border)	9.5 × 11 inches (241 × 279 mm)	14.8 × 11 inches (376 × 279 mm)
Single sheet	A4 or letter size	A3 landscape

If you use single sheets, you need to load a new sheet of paper each time the printer ejects a printed sheet from the paper guide.

Follow these steps to perform the bidirectional adjustment:

1. Make sure paper is loaded, then turn off the printer.
2. While holding down the Pause button, turn on the printer. The printer enters the bidirectional adjustment mode and then prints instructions and the first set of alignment patterns.
3. As described in the instructions, compare the alignment patterns and select the pattern with the best alignment. Then select the pattern with the best alignment for each of the remaining sets of alignment patterns.
4. After you select the best pattern in the final set of alignment patterns, save your selection by turning off the printer.

## Printing a Self Test

Running the printer's self test helps you determine whether the printer or the computer is causing the problem:

- ❑ If the self test results are satisfactory, the printer is working properly and the problem probably results from your printer driver settings, application settings, computer, or interface cable. (Be sure to use a shielded interface cable.)
- ❑ If the self test does not print properly, there is a problem with the printer.

You can print the self test using either single sheets or continuous paper of at least the following width:

Paper type	FX-880+	FX-1180+
Continuous paper (including perforated border)	9.5 inches (241 mm)	14.8 inches (376 mm)
Single sheet	A4 or letter size	A3 landscape

Follow these steps to perform a self test:

1. Make sure paper is loaded and the printer is turned off.
2. To run the test using the Draft font, turn on the printer while holding down the LF/FF button. To run the test using the printer's near letter-quality fonts, hold down the Load/Eject button while you turn on the printer. Either self test can help you determine the source of your printing problem; however, the draft self test prints faster than the near letter-quality test.

After a few seconds, the printer loads the paper automatically and begins printing the self test. A series of characters is printed.



To temporarily stop the self test, press the Pause button. To resume the test, press Pause again.

3. To end the self test, press the **Pause** button to stop printing. If paper remains in the printer, press the **Load/Eject** button to eject the printed page. Then turn off the printer.



Do not turn off the printer while it is printing the self test. Always press the Pause button to stop printing and the Load/Eject button to eject the printed page before you turn off the printer.

## Printing a Hex Dump

The hex dump feature is designed for DOS-based PC connections. If you are an experienced user or a programmer, you can print a hexadecimal dump to isolate communication problems between the printer and your software program. In hex dump mode, the printer prints all data it receives from the computer as hexadecimal values.

You can print a hex dump using either single sheets or continuous paper that is at least 8.3 inches (210 mm) wide, such as A4 or letter size paper.

1. Make sure paper is loaded and the printer is turned off.
2. To enter hex dump mode, turn on the printer while holding down the LF/FF and Load/Eject buttons.
3. Open a software program and send a print job to the printer. Your printer prints all the codes it receives in hexadecimal format, such as:

```
1B 40 20 54 68 69 73 20 69 73 20 61 6E 20 65 78 .@ This is an ex
61 6D 70 6C 65 20 6F 66 20 61 20 68 65 7B 20 64 ample of a hex d
75 6D 70 20 70 72 69 6E 74 6F 75 74 2E 0D 0A ump printout...
```

4. By comparing the characters printed in the right column with the printout of the hexadecimal codes, you can check the codes the printer is receiving. If characters are printable, they appear in the right column as ASCII characters. Nonprintable codes, such as control codes, are represented by dots.
5. To turn off hex dump mode, press the **Pause** button, eject the printed page(s), and then turn off the printer.



Do not turn off the printer while it is printing the hex dump. Always press the Pause button to stop printing and the Load/Eject button to eject the printed page before you turn off the printer.

## Resetting the Printer

To reset the printer's EEPROM, hold down the **Load/Eject**, **LF/FF**, and **Pause** buttons while turning on the printer. The printer beeps once, and restores its factory default settings.



---

## Cleaning the Printer

---

1. Remove any paper loaded in the printer and turn it off.
2. Unplug the power cord from the electrical outlet; then disconnect the interface cable from the printer.
3. Remove the paper guide. If a pull tractor or an optional cut-sheet feeder is installed, remove it.
4. Use a soft brush to carefully brush away all dust and dirt from the outer case and paper guide.
5. If the outer case or paper guide is still dirty, clean it with a soft, clean cloth dampened with mild detergent dissolved in water. Keep the printer cover closed to prevent water from getting inside the printer.



Never use alcohols or thinners to clean the printer; these chemicals can damage the printer components as well as the case.

Be careful not to get water on the printer mechanism or electronic components.

Do not use a hard or abrasive brush.

Do not spray the inside of the printer with lubricants; unsuitable oils can damage the printer mechanism. Contact an EPSON dealer if you think lubrication is needed.

7. Repack the printer, paper guide, ribbon cartridge, and power cord in the original packing materials and place them in the printer's original box.

---

## Related Documentation

---

4014600-00/ CPD-12721	EPSON FX-880+/1180+ User's Guide
4014598-00	EPSON FX-880+/1180+ Setup Guide
3010030-01	CD-ROM containing online Reference Guide and Quick Guide
TM-FX8/1180+	EPSON FX-880+/1180+ Service Manual
PL-FX8/1180+	EPSON FX-880+/1180+ Parts Price List

---

## Transporting the Printer

---

If you need to transport your printer some distance, carefully repack it using the original box and packing materials, as described below.



You need to move the print head by hand to remove the ribbon cartridge. If you have just used the printer, the print head may be hot; let it cool for a few minutes before touching it.

1. Remove any paper in the printer and turn it off.
2. Unplug the power cord from the electrical outlet; then disconnect the interface cable from the printer.
3. Remove the paper guide.
4. If any options are installed, remove them and pack them in their original boxes.
5. Make sure that the print head is not hot. Then remove the ribbon cartridge.
6. Make sure the paper tension unit is installed and the tractor is installed in the rear push position. Also make sure the printer cover and front cover are closed.