

EPSON®

Epson® SureColor® F10070/F10070H/F11070/F11070H Installation Site Survey

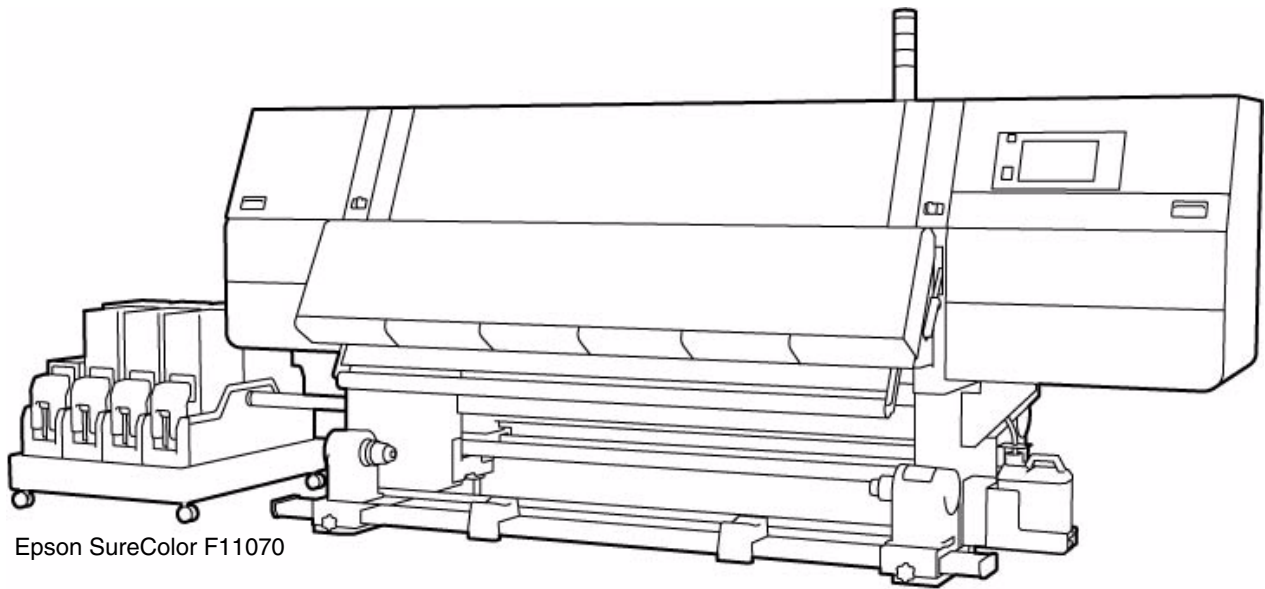

Epson SureColor F11070

The Dealer or Epson representative is responsible for conducting the site survey and must check the confirmation boxes in this document to confirm that all requirements have been met.

If any of the information provided by the customer on the site survey is inaccurate, the customer is responsible for the cost of additional installation visit(s).

The Dealer or Epson representative should email the completed site survey and required photographs to EpsonSiteSurvey@ea.epson.com.

Earliest delivery date to customer facility: _____.

Please provide the earliest date that the customer facility is able to receive the printer. This information will be relayed to the Epson installation and scheduling team who will contact customer directly regarding available delivery dates based on product and installer availability.

Customer/Delivery Information

Company Name	
Company Address (include City, State/Province, Zip/Postal Code)	
Printer Delivery Address (if different from above)	
Contact Name(s)	
Contact Phone Number(s) and Email Address(es)	

Dealer/Reseller Information

Company Name		Choose one: <input type="checkbox"/> Epson installation <input type="checkbox"/> Dealer installation <input type="checkbox"/> Dealer stock order ¹
Contact Name		
Contact Phone Number and Email Address		

¹ Dealer order for stocking. Printer will ship to reseller location, dock to dock; end customer has not been determined. Make sure the shipping information above is correct. If this box is checked, you do not need to complete the rest of the site survey.

Site Survey Conducted By

Company Name	
Contact Name	
Contact Phone Number and Email Address	

Epson Field Service Support Technician

Technician Name	
Technician Phone Number and Email Address	

Epson Channel Manager

Channel Manager Name	
Channel Manager Phone Number and Email Address	

Printer SKUs

Description	Requirements	Requirements met
Options	<p>Customer understands that the following SKUs are available (availability varies by region) and the service providers differ:</p> <ul style="list-style-type: none"> • SCF10070WG, SCF11070WG, SCF11070LWG, SCF10070HWG, SCF11070HWG, SCF11070HLWG Includes freight, White Glove delivery, and installation from Epson. • SCF10070DI, SCF11070DI, SCF11070LDI, SCF10070HDI, SCF11070HDI, SCF11070HLDI Includes dock-to-dock only freight by Epson. Additional services may be provided by a reseller. Please confirm with your reseller. 	Y <input type="checkbox"/> N <input type="checkbox"/>

Warranty and Service Plans

Description	Requirements	Requirements met
Options	<p>Customer understands that the printer comes with a 90-day limited warranty and purchase of one of the following extended service plans is required as part of the initial purchase.</p> <ul style="list-style-type: none"> • PSF10070FS1, PSF11070FS1 One-year service and support plan • PSF10070SS1, PSF11070SS1 One-year service and support plan with print head self-service • PSF10070SS3, PSF11070SS3 Three-year service and support plan with print head self-service • PSF10070SS5, PSF11070SS5 Five-year service and support plan with print head self-service <p>Note: The print head self-service plans require the printer to have a stable and continuous internet connection. Failure to provide this could cause the service plan to be refunded and service to be affected.</p>	Y <input type="checkbox"/> N <input type="checkbox"/>

Ink

Description	Requirements	Requirements met
Ink purchase	<p>Customer understands that ink is not included with the printer.</p> <p>The customer is required to purchase ink with the initial printer order and have that ink available when the installer arrives.</p>	Y <input type="checkbox"/> N <input type="checkbox"/>

Loading Dock

Description	Requirements	Requirements met
Measurements	<p>Is a loading dock available at the installation site?</p> <p>Dock door width: ___ ft ___ in./ ___ m ___ cm</p> <p>Dock height: ___ ft ___ in./ ___ m ___ cm</p> <div data-bbox="636 974 1143 1394" style="text-align: center;"> <p>The diagram shows a cross-section of a loading dock. A horizontal red double-headed arrow spans the width of the dock door, labeled 'Dock door width'. A vertical red double-headed arrow indicates the height from the ground to the bottom of the dock door, labeled 'Dock height'. The dock structure is shown in grey, with yellow vertical bars on the ground level.</p> </div> <p>If a loading dock is not available, a truck with a liftgate is required.</p> <p>Note: Photograph required.</p>	Y <input type="checkbox"/> N <input type="checkbox"/>
Unloading area	<p>If there is no loading dock, is there enough room outside the facility to unload the printer? A minimum 100 ft (30.5 m) long parking lot is required.</p> <p>Note: Photograph required.</p>	Y <input type="checkbox"/> N <input type="checkbox"/>

Vehicle Restrictions

Description	Requirements	Requirements met
Vehicle restrictions	Are there any vehicle restrictions at the facility, such as height constraints, city center restrictions, or dock constraints? If yes, describe constraints below:	Y <input type="checkbox"/> N <input type="checkbox"/>

Space Requirements

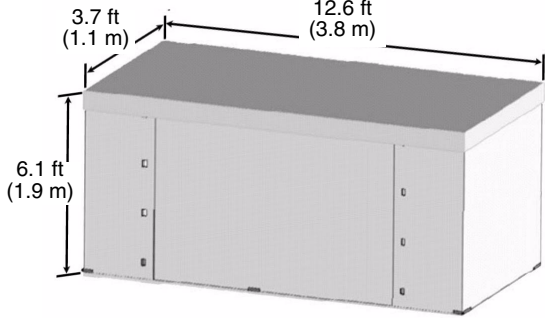
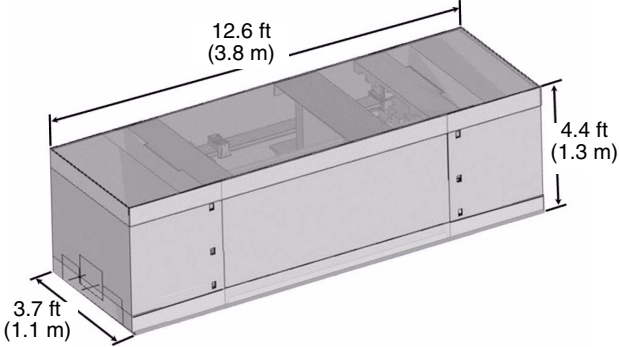
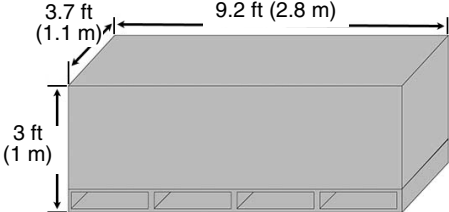
Description	Requirements	Requirements met
Unpacking area	Is there appropriate space inside to unload, uncrate, unpack, and install the printer? Note: Photograph required.	Y <input type="checkbox"/> N <input type="checkbox"/>
	<p>Printer</p> 	
	<p>Option set</p> 	
<p>Jumbo roll unit option</p> 		

Space Requirements, continued

Description	Requirements	Requirements met
Carry-in route	<p>Are all doorways and halls between the unloading/unpacking location and the installation location of sufficient width to accommodate the printer? If no, please describe the issue:</p> <p>Recommended doorway width: 77 in. (195.6 cm) minimum.</p> <p>Printer dimensions: 146 in. W x 54 in. D x 76 in. H (371 cm W x 137 cm D x 193 cm H)</p> <p>Printer weight: 1,623 lb (736 kg)</p> <p>Note: Photograph required.</p>	Y <input type="checkbox"/> N <input type="checkbox"/>
Floor protection	<p>Is floor protection required to transport the product inside the facility?</p> <p>If yes, specify the type of protective material required (e.g., cardboard, plywood, metal):</p>	Y <input type="checkbox"/> N <input type="checkbox"/>
Upper floor	<p>Will the printer be delivered to an upper floor in the facility? If yes, specify floor and room: _____</p>	Y <input type="checkbox"/> N <input type="checkbox"/>
	<p>Is the use of freight elevator or equivalent required?</p> <p>If yes, it must be able to accommodate the size and load bearing requirements of the printer. See dimensions in "Carry-in route" above.</p> <p>Note: Photograph required.</p>	Y <input type="checkbox"/> N <input type="checkbox"/>
	<p>Will a crane be used?</p> <p>If yes, make sure the following preparations have been made:</p> <ul style="list-style-type: none"> • If using a sling, provide a stable support for the printer. Provide protection to ensure the sling wire does not touch or damage the printer. • If using a gondola lift, ensure it can contain the printer. 	Y <input type="checkbox"/> N <input type="checkbox"/>
Personal Protective Equipment (PPE)	<p>Does the facility require any PPE to enter? If Yes, specify PPE (e.g., goggles, hard hat, mask, gloves):</p>	Y <input type="checkbox"/> N <input type="checkbox"/>

Space Requirements, continued

Description	Requirements	Requirements met
Certificate of insurance	Does the building require a certificate of insurance? If yes, explain how this information should be provided:	Y <input type="checkbox"/> N <input type="checkbox"/>

Forklift

Description	Requirements	Requirements met
Forklift	<p>Is a forklift available for unloading the packages from a truck and unloading the main unit on a pallet?</p> <p>Forklift requirements:</p> <ul style="list-style-type: none"> • Load bearing: 3,000 lb (1,360 kg) • Length of forks when moving the carton/load handling: <ul style="list-style-type: none"> • 39 in. (99 cm) (forks inserted from the depth [front/rear] direction) • 95 in. (241 cm) (forks inserted from the length [side] direction) • Length of forks when moving the main unit: 47.2 in. (120 cm) (forks inserted from the depth direction) <p>Select forklift so that packages can be moved safely according to the fork insertion direction.</p>	Y <input type="checkbox"/> N <input type="checkbox"/>

Printer Room

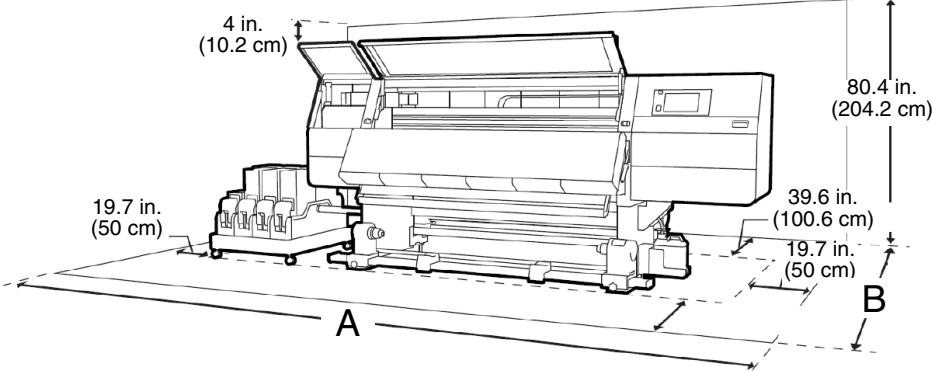
Description	Requirements	Requirements met
Floor space	Is there enough space around the printer to operate it safely?	Y <input type="checkbox"/> N <input type="checkbox"/>
	<div style="text-align: center;">  </div> <p> A. F10070/F11070: 220.8 in. (560.1 cm) F10070H/F11070H: 236.6 in. (601 cm) </p> <p> B. 129.6 in. (329.2 cm) With jumbo roll and standard reel: 151.2 in (384 cm) </p> <p>Note: Photograph required.</p>	
Floor load bearing	Will the floor support the weight of the printer? <ul style="list-style-type: none"> • F10070 with standard roll and standard reel: 1,623 lb (736 kg) • F10070H with standard roll and standard reel: 1,695 lb (769 kg) • F10070/F11070 with jumbo roll and standard reel: 1,905 lb (864 kg) • F10070H/F11070H with jumbo roll and standard reel: 1,973 lb (895 kg) <p>Note: Reinforce the floor if necessary.</p>	Y <input type="checkbox"/> N <input type="checkbox"/>
Floor stability	Is the floor stable (vibration free) and level (levelness within +/- 0.9 degrees [15.3 mm/m])?	Y <input type="checkbox"/> N <input type="checkbox"/>
Temperature	Can the following environmental conditions be met? 64.4 ~ 82 °F (18 ~ 27.8 °C) when printing 50 ~ 95 °F (10 ~ 35 °C) when printing	Y <input type="checkbox"/> N <input type="checkbox"/>
Humidity	Can the following environmental conditions be met? 40~60% relative humidity (RH) during printing.	Y <input type="checkbox"/> N <input type="checkbox"/>
Cleanliness	Can the following conditions be met? <ul style="list-style-type: none"> • No dirt or dust accumulation • No source of dust, such as a carpet, nearby 	Y <input type="checkbox"/> N <input type="checkbox"/>

Printer Room, continued

Description	Requirements	Requirements met
Environment	<p>Can the following environmental conditions be met?</p> <ul style="list-style-type: none"> • Area not in direct sunlight • Area not directly under a heating/cooling vent 	Y <input type="checkbox"/> N <input type="checkbox"/>
Electrical outlet	<p>Can the following power requirements be met?</p> <ul style="list-style-type: none"> • Single-phase AC 200-240V +/- 10% (50/60 Hz) • Lines/outlets professionally installed by a licensed electrician prior to printer installation:  <ul style="list-style-type: none"> • 20A x 2 for standard roll and standard reel • 20A x 3 for jumbo roll and standard reel • Minimum 200VAC stable under continuous 30A load • The following safety equipment is installed in accordance with the local electrical code: <ul style="list-style-type: none"> • Overcurrent protection breaker: 20A • Ground-fault circuit interrupters (GFCI) • Grounding <p>Note: If the 220V outlets are not installed at the time of printer installation, Epson reserves the right to bill for additional installation charges resulting from the delay.</p> <p>Note: Photograph required.</p>	Y <input type="checkbox"/> N <input type="checkbox"/>
Power consumption (total of power connection #1/power connection #2)	<p>Are you aware of the following power consumption?</p> <ul style="list-style-type: none"> • During operation: approximately 3.9 KW or less • When power is off: approximately 9.6 W or less 	Y <input type="checkbox"/> N <input type="checkbox"/>
AC power cable	<p>Are you using the included power cables or if not, can these power cable requirements be met?</p> <ul style="list-style-type: none"> • Power cable corresponding to the above power source x 2 cables. • Power cables comply with local electrical code. 	Y <input type="checkbox"/> N <input type="checkbox"/>
Air compressor for jumbo roll	<p>Can the following air compressor requirements be met?</p> <p>0.45 to 1.0 MPa (450 to 1000 kPa)</p>	Y <input type="checkbox"/> N <input type="checkbox"/>

Waste Ink Disposal

Description	Requirements	Requirements met
Waste ink disposal	<p>Has the customer checked local laws and regulations to determine the correct method to dispose of waste ink?</p> <p>Visit epson.com/support/sds (U.S.) or epson.ca/support/sds (Canada) for ink Safety Data Sheet (SDS) documents.</p>	Y <input type="checkbox"/> N <input type="checkbox"/>

Computer

Description	Requirements	Requirements met
Internet access	<p>Is an Ethernet connection available that meets the following requirements?</p> <ul style="list-style-type: none"> • Standard Ethernet port with internet access within 10 ft (3 m) of the printer port where the printer will be installed <p>Note: Photograph required.</p> <ul style="list-style-type: none"> • Category 6 Ethernet cable no more than 10 ft (3 m) in length • High-speed Ethernet network with internet access setup prior to printer installation • Network speed: _____ <p>Note:</p> <ul style="list-style-type: none"> • The printer is not compatible with wireless or fiber optic connections. • Disable any network firewalls or security programs that may interfere with data sent to and from the printer. • Have an IT professional assist, if needed. • The service and support plans with print head self-service require a stable and continuous internet connection. 	Y <input type="checkbox"/> N <input type="checkbox"/>
Computer specifications	<p>Does the computer meet these minimum specifications?</p> <ul style="list-style-type: none"> • Multicore processor • 2GB RAM • 32GB available storage space • 1024 x 768 monitor 	Y <input type="checkbox"/> N <input type="checkbox"/>

Computer, continued

Description	Requirements	Requirements met
3rd-party software	<p>If using 3rd-party software to drive the printer, list software name and system requirements below:</p> <p>Note: Epson supports workflow only through the Epson Edge Print software. 3rd-party software support is the customer's responsibility.</p>	Y <input type="checkbox"/> N <input type="checkbox"/>

Epson Cloud Solution PORT and Remote Monitoring

Description	Requirements	Requirements met
Software	Customer understands that registering for Epson Cloud Solution PORT and Epson Remote Monitoring System is a requirement for this product?	Y <input type="checkbox"/> N <input type="checkbox"/>
Internet access	Will internet access be available at the time of installation?	Y <input type="checkbox"/> N <input type="checkbox"/>
	Will continuous internet access be available for Epson to provide remote service monitoring? (Service may be impacted if remote monitoring is not implemented.)	Y <input type="checkbox"/> N <input type="checkbox"/>

Required Photographs

Description	Requirements	Requirements met
Photographs	<p>Photos of the following areas have been taken:</p> <ul style="list-style-type: none"> • Access to the installation site, including: <ul style="list-style-type: none"> • Loading dock • Unloading area • Freight elevator • Doorways and path to the final printer location • Power outlets • Ethernet accessibility • Final printer location 	Y <input type="checkbox"/> N <input type="checkbox"/>

Customer Sign-off

Important:

- If any of the installation requirements outlined in this survey are not in place at the time of delivery/installation, Epson reserves the right to bill for additional charges required to meet the installation requirements or caused by the delay. Incomplete site preparation could also result in delays in completing your installation.
- If there are any additional installation requirements, such as rigging or a crane, there may be additional charges. These charges will be provided prior to the approval of the site survey and final quote.

If there are any concerns or issues, please describe in detail below:

--

After completing the survey, sign below. By signing, customer agrees that all information in this site survey is as accurate as possible and the required photographs will be included.

Customer name (printed)	Title (required)	Customer signature	Date

Epson representative name (printed)	Title (required)	Epson representative signature	Date

The Dealer or Epson representative should email the completed site survey and required photographs to EpsonSiteSurvey@ea.epson.com.

EPSON is a registered trademark and the EPSON logo is a registered logomark of Seiko Epson Corporation.

Epson Preferred is a service mark of Epson America, Inc.

Windows is a registered trademarks of the Microsoft group of companies.

General Notice: Other product names used herein are for identification purposes only and may be trademarks of their respective owners. Epson disclaims any and all rights in those marks.