

# Epson® SureColor® F3070 Installation Site Survey

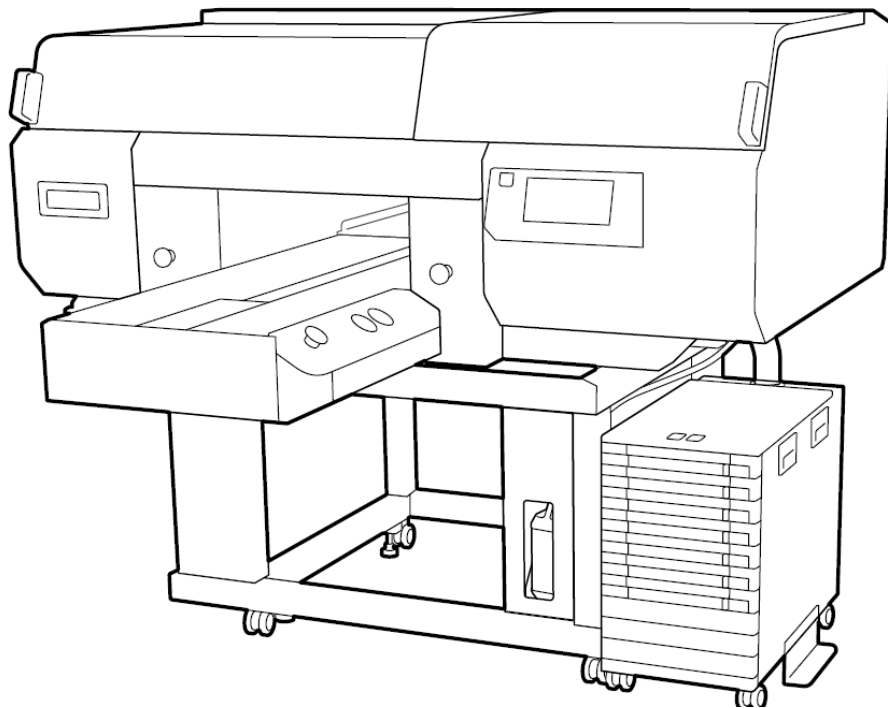

The Dealer or Epson Representative responsible for conducting the survey must check the confirmation boxes in this document to confirm that all requirements have been met.

Customer must confirm all requirements have been met and sign survey.

Dealer or Epson Representative to email completed survey and required photographs to [EpsonSiteSurvey@ea.epson.com](mailto:EpsonSiteSurvey@ea.epson.com).

## Earliest delivery date to customer facility: \_\_\_\_\_.

Please provide the earliest date that the customer facility is able to receive the printer. This information will be relayed to the Epson installation and scheduling team who will contact customer directly regarding available delivery dates based on product and installer availability.

## Customer/Delivery Information

<b>Company Name</b>	
<b>Company Address (include City, State/Province, Zip/Postal Code)</b>	
<b>Printer Delivery Address (if different from above)</b>	
<b>Contact Name(s)</b>	
<b>Contact Phone Number(s) and Email Address(es)</b>	

## Dealer/Reseller Information

<b>Company Name</b>		Choose one: <input type="checkbox"/> Epson installation <input type="checkbox"/> Dealer installation <input type="checkbox"/> Dealer stock order <sup>1</sup>
<b>Contact Name</b>		
<b>Contact Phone Number and Email Address</b>		

<sup>1</sup> Dealer order for stocking. Printer will ship to reseller location, dock to dock; end customer has not been determined. Make sure the shipping information above is correct. If this box is checked, you do not need to complete the rest of the site survey.

## Site Survey Conducted By

<b>Company Name</b>	
<b>Contact Name</b>	
<b>Contact Phone Number and Email Address</b>	

## Epson Field Service Support Technician

<b>Technician Name</b>	
<b>Technician Phone Number and Email Address</b>	

## Epson Channel Manager

<b>Channel Manager Name</b>	
<b>Channel Manager Phone Number and Email Address</b>	

## Printer SKUs

Description	Requirements	Requirements met
Options	<p>Customer understands that Epson offers the following SKUs (availability varies by region) and the service providers differ:</p> <ul style="list-style-type: none"> <li>• SCF3070WG Includes freight, White Glove delivery, and installation from Epson.</li> <li>• SCF3070DI Includes dock-to-dock only freight by Epson. Additional services may be provided by a reseller. Please confirm with your reseller.</li> </ul>	Y <input type="checkbox"/> N <input type="checkbox"/>

## Service Plans

Description	Requirements	Requirements met
Options	<p>Customer understands that the printer comes with a 90-day limited warranty and purchase of one of the following extended service plans is required as part of the initial purchase.</p> <ul style="list-style-type: none"> <li>• EPPF3070FS1 One-year service and support plan</li> <li>• EPPF3070SS1 One-year service and support plan with print head self-service</li> <li>• EPPF3070SS3 Three-year service and support plan with print head self-service</li> <li>• EPPF3070SS5 Five-year service and support plan with print head self-service</li> </ul> <p><b>Note:</b> The print head self-service plans require the printer to have a stable and continuous internet connection. Failure to provide this could cause the service plan to be refunded and service to be affected.</p>	Y <input type="checkbox"/> N <input type="checkbox"/>

## Loading Dock

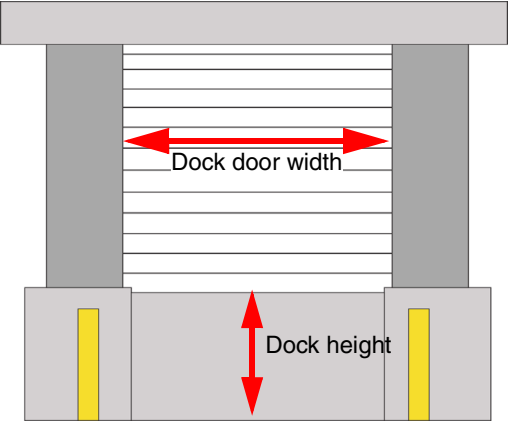
Description	Requirements	Requirements met
Measurements	<p>Is a loading dock available at the installation site?</p> <p>Dock door width: _____ feet _____ inches            _____ m _____ cm</p> <p>Dock height: _____ feet _____ inches            _____ m _____ cm</p>  <p>The diagram shows a cross-section of a loading dock. It consists of a concrete base with two vertical pillars. A horizontal door with horizontal slats is mounted between the pillars. A red double-headed arrow spans the width of the door, labeled 'Dock door width'. Another red double-headed arrow spans the height from the top of the concrete base to the bottom of the door, labeled 'Dock height'.</p> <p>If a loading dock is not available, a truck with a liftgate is required.  <b>Note:</b> Photograph required.</p>	Y <input type="checkbox"/> N <input type="checkbox"/>
Unloading area	<p>If there is no loading dock, are either of the following true?</p> <ul style="list-style-type: none"> <li>• There is enough room outside the facility to unload the printer.</li> <li>• There is a liftgate available.</li> </ul> <p><b>Note:</b> Photograph required.</p>	Y <input type="checkbox"/> N <input type="checkbox"/>

## Vehicle Restrictions

Description	Requirements	Requirements met
Vehicle restrictions	Are there any vehicle restrictions at the facility, such as height constraints, city center restrictions, or dock constraints? If Yes, describe constraints below:	Y <input type="checkbox"/> N <input type="checkbox"/>

## Space Requirements

Description	Requirements	Requirements met
Unpacking area	<p>Is there appropriate space inside to unload, uncrate, unpack, and position the printer?</p> <div data-bbox="641 903 1201 1281" data-label="Image"> </div> <p><b>Note:</b> Photograph required.</p>	Y <input type="checkbox"/> N <input type="checkbox"/>
Carry-in route	<p>Are all doorways and halls between the unloading/unpacking location and the installation location of sufficient width to accommodate the printer? If No, describe issue:</p> <p>Recommended width of doorways: 77 in. (195.6 cm) minimum.</p> <p>Printer dimensions: 67 in. W x 70 in. D x 52 in. H (170.2 cm W x 177.8 cm D x 132.1 cm H)</p> <p><b>Note:</b> Photograph required.</p>	Y <input type="checkbox"/> N <input type="checkbox"/>

## Space Requirements, continued

Description	Requirements	Requirements met
Floor protection	<p>Is floor protection required to transport the product inside the facility?</p> <p>If Yes, specify type of protective material required (e.g., cardboard, plywood, metal):</p>	Y <input type="checkbox"/> N <input type="checkbox"/>
Upper floor	<p>Will the printer be delivered to an upper floor within the facility? If Yes, specify floor and room:</p>	Y <input type="checkbox"/> N <input type="checkbox"/>
	<p>Is the use of freight elevator or equivalent required?</p> <p>If Yes, it must be able to accommodate the size and load bearing requirements of the printer. See dimensions in "Carry-in route" above.</p> <p><b>Note:</b> Photograph required.</p>	Y <input type="checkbox"/> N <input type="checkbox"/>
	<p>Will a crane be used?</p> <p>If Yes, make sure the following preparations have been made:</p> <ul style="list-style-type: none"> <li>• When using a sling: Provide a stable support for the printer. <b>Provide protection to ensure the sling wire does not touch and damage the printer.</b></li> <li>• When using a gondola lift, ensure it is able to contain the printer.</li> </ul>	Y <input type="checkbox"/> N <input type="checkbox"/>
Personal Protective Equipment (PPE)	<p>Does the facility require any PPE to enter? If Yes, specify PPE (e.g., goggles, hard hat, mask, gloves):</p>	Y <input type="checkbox"/> N <input type="checkbox"/>
Certificate of insurance	<p>Does the building require a certificate of insurance? If Yes, explain how this information should be provided:</p>	Y <input type="checkbox"/> N <input type="checkbox"/>

## Forklift

Description	Requirements	Requirements met
Forklift	<p>Is a forklift that meets the requirements below available for unloading the packages from a truck and unloading the main unit from a pallet?</p> <p>Forklift requirements:</p> <ul style="list-style-type: none"> <li>• Load bearing: 3,300 lb (1,497 kg)</li> <li>• Minimum fork lengths for moving the carton:               <ul style="list-style-type: none"> <li>• 73 in. (185 cm) (forks inserted from the depth [front/rear] direction)</li> <li>• 90.5 in. (230 cm) (forks inserted from the length [side] direction)</li> </ul> </li> </ul> <p>Select forklift so that packages can be moved safely according to the fork insertion direction.</p>	Y <input type="checkbox"/> N <input type="checkbox"/>

## Printer Room

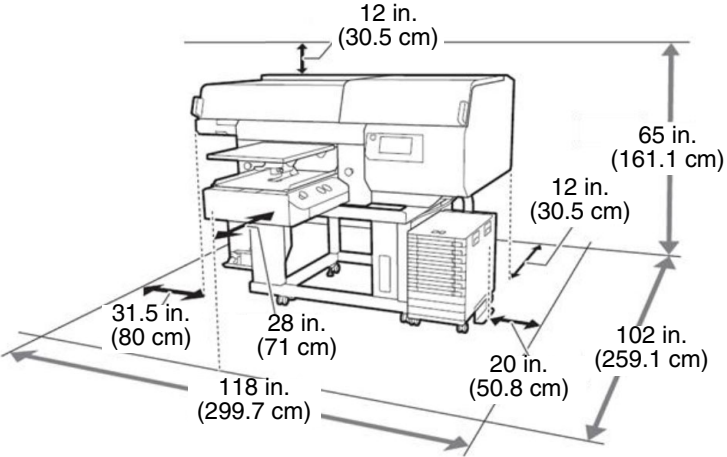
Description	Requirements	Requirements met
Floor space	<p>Is there enough space around the printer to operate it safely?</p>  <p><b>Note:</b> Photograph required.</p>	Y <input type="checkbox"/> N <input type="checkbox"/>
Floor load bearing	<p>Will the floor support 72 lb/ft<sup>2</sup> (351.5 kg/m<sup>2</sup>)?</p> <p><b>Note:</b> Reinforce the floor if necessary.</p>	Y <input type="checkbox"/> N <input type="checkbox"/>
Floor stability	<p>Is the floor stable (vibration free) and level (levelness within +/- 0.5 degrees [8.3 mm/m])?</p>	Y <input type="checkbox"/> N <input type="checkbox"/>

## Printer Room, continued

Description	Requirements	Requirements met
Temperature	Can the following environmental conditions be met? <ul style="list-style-type: none"> <li>• 50 ~ 95 °F (10 ~ 35 °C) during initial ink charge</li> <li>• 59 ~ 77 °F (15 ~ 25 °C) when printing</li> </ul>	Y <input type="checkbox"/> N <input type="checkbox"/>
Humidity	Can the following environmental conditions be met? 40 ~ 60% RH during printing	Y <input type="checkbox"/> N <input type="checkbox"/>
Cleanliness	Can the following conditions be met? <ul style="list-style-type: none"> <li>• No dirt or dust accumulation</li> <li>• No source of dust, such as a carpet, nearby</li> <li>• No source of misting, such as a pretreatment machine, nearby</li> </ul>	Y <input type="checkbox"/> N <input type="checkbox"/>
Environment	Can the following environmental conditions be met? <ul style="list-style-type: none"> <li>• Area not in direct sunlight</li> <li>• Area not directly under a heating/cooling vent</li> </ul>	Y <input type="checkbox"/> N <input type="checkbox"/>
Electrical outlet	Can the following power requirements be met? <ul style="list-style-type: none"> <li>• Single-phase AC100~240, 10A × 2 line</li> <li>• The following safety equipment is installed in accordance with the local electrical code:               <ul style="list-style-type: none"> <li>• Overcurrent protection breaker: Recommend 10-15A</li> <li>• Ground-fault circuit interrupters (GFCI)</li> <li>• Grounding</li> </ul> </li> </ul> <p><b>Note:</b> If the required power outlets are not installed or available prior to the scheduled installation date, the installation could be delayed.</p> <p><b>Note:</b> Photograph required.</p>	Y <input type="checkbox"/> N <input type="checkbox"/>
AC power cable	Are you using the included power cables (two standard length power cables are provided with printer) or if not, can these power cable requirements be met?  Power cable corresponding to the above power source × 2 cables.	Y <input type="checkbox"/> N <input type="checkbox"/>

## Waste Ink Disposal

Description	Requirements	Requirements met
Waste ink disposal	<p>Has the correct method for disposing waste ink (according to local ordinances) been verified?</p> <p>Visit <a href="http://epson.com/support/sds">epson.com/support/sds</a> (U.S.) or <a href="http://epson.ca/support/sds">epson.ca/support/sds</a> (Canada) for ink Safety Data Sheet (SDS) documents.</p>	Y <input type="checkbox"/> N <input type="checkbox"/>

## Computer

Description	Requirements	Requirements met
Internet access	<p>Is an Ethernet connection available that meets the following requirements?</p> <ul style="list-style-type: none"> <li>Standard Ethernet port with internet access within 10 ft (3 m) of the printer port where the printer will be installed</li> </ul> <p><b>Note:</b> Photograph required.</p> <ul style="list-style-type: none"> <li>Category 6 Ethernet cable no more than 10 ft (3 m) in length</li> <li>High-speed Ethernet network with internet access setup prior to printer installation</li> <li>Network speed: _____</li> </ul> <p><b>Note:</b></p> <ul style="list-style-type: none"> <li>The printer is not compatible with wireless or fiber optic connections.</li> <li>Disable any network firewalls or security programs that may interfere with data sent to and from the printer.</li> <li>Have an IT professional assist, if needed.</li> <li>The service and support plans with print head self-service require a stable and continuous internet connection.</li> </ul>	Y <input type="checkbox"/> N <input type="checkbox"/>
Computer specifications	<p>Does the computer meet these minimum specifications?</p> <ul style="list-style-type: none"> <li>Multicore processor</li> <li>2GB RAM</li> <li>32GB available storage space</li> <li>1024 x 768 monitor</li> </ul>	Y <input type="checkbox"/> N <input type="checkbox"/>

## Computer, continued

Description	Requirements	Requirements met
3rd-party software	<p>If using 3rd-party software to drive the printer, list software name and system requirements below:</p> <p><b>Note:</b> Epson supports workflow only through the Garment Creator software. 3rd-party software support is the customer's or reseller's responsibility.</p>	Y <input type="checkbox"/> N <input type="checkbox"/>

## Epson Cloud Solution PORT and Remote Monitoring

Description	Requirements	Requirements met
Software	Customer understands that registering for Epson Cloud Solution PORT and Epson Remote Monitoring System is a requirement for this product?	Y <input type="checkbox"/> N <input type="checkbox"/>
Internet access	Internet access is available at time of installation.	Y <input type="checkbox"/> N <input type="checkbox"/>
	Continuous internet access is available for Epson to provide remote service monitoring. (Without remote monitoring, service may be affected.)	Y <input type="checkbox"/> N <input type="checkbox"/>

## Required Photographs

Description	Requirements	Requirements met
Photographs	<p>Photos of the following areas have been taken:</p> <ul style="list-style-type: none"> <li>• Access to the installation site, including: <ul style="list-style-type: none"> <li>• Loading dock</li> <li>• Freight elevator</li> <li>• Doorways and path to the final printer location</li> </ul> </li> <li>• Ethernet accessibility</li> <li>• Final printer location</li> </ul>	Y <input type="checkbox"/> N <input type="checkbox"/>

## Customer Sign-off

### Important:

- If any of the installation requirements outlined in this survey are not in place at the time of delivery/installation, Epson reserves the right to bill for additional charges required to meet the installation requirements or caused by the delay. Incomplete site preparation could also result in delays in completing your installation.
- If there are any additional installation requirements, such as rigging or a crane, there may be additional charges required. These charges will be provided prior to the approval of the site survey and final quote.
- During installation, we require those who will be on-site to follow appropriate social distancing guidelines. Additionally, we require that masks be worn by anyone who will be in contact with the installers/technicians.

If there are any concerns or issues, please describe in detail below:

After completing the survey, sign below. By signing, customer agrees that all information in this site survey is as accurate as possible and the required photographs will be included.

Customer name (printed)	Title (required)	Customer signature	Date

Dealer or Epson Representative to email completed survey and required photographs to [EpsonSiteSurvey@ea.epson.com](mailto:EpsonSiteSurvey@ea.epson.com).

EPSON and SureColor are registered trademarks of Seiko Epson Corporation. Epson Preferred is a service mark of Epson America, Inc. General Notice: Other product names used herein are for identification purposes only and may be trademarks of their respective owners. Epson disclaims any and all rights in those marks.