

TM-S9000II-NW

Technical Reference Guide

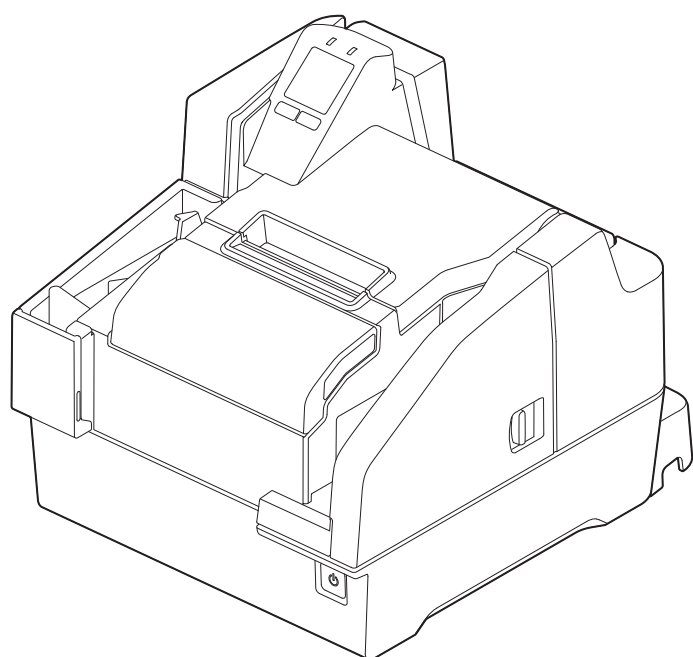

Safety Precautions

Describes precautions that ensure safe use of the product. Read this first.

Product Overview

Describes product features.

Setup

Describes product and peripheral device installation and setup procedures.

Advanced Product Use

Describes advanced product use.

Application Development Information

Provides information required for controlling this product and application development.

Handling the Product

Describes the basic operating procedures of the product.

Troubleshooting

Describes what to do when problems occur.

Product Specifications

Provides product specifications, interface specifications, and character code tables.

CAUTIONS

- No part of this document may be reproduced, stored in a retrieval system, or transmitted in any form or by any means, electronic, mechanical, photocopying, recording, or otherwise, without the prior written permission of Seiko Epson Corporation.
- The contents of this document are subject to change without notice. Please contact us for the latest information.
- While every precaution has been taken in the preparation of this document, Seiko Epson Corporation assumes no responsibility for errors or omissions.
- Neither is any liability assumed for damages resulting from the use of the information contained herein.
- Neither Seiko Epson Corporation nor its affiliates shall be liable to the purchaser of this product or third parties for damages, losses, costs, or expenses incurred by purchaser or third parties as a result of accident, misuse, or abuse of this product or unauthorized modifications, repairs, or alterations to this product, or (excluding the U.S.) failure to strictly comply with Seiko Epson Corporation's operating and maintenance instructions.
- Seiko Epson Corporation shall not be liable for any damages or problems arising from the use of any options or any consumable products other than those designated as Genuine Epson Products or Epson Approved Products by Seiko Epson Corporation.

Copyrights

Microsoft® and Windows® are registered trademarks of Microsoft Corporation in the United States, Japan, and/or other countries.

Wi-Fi®, WPA™, WPA2™, and WPA3™ are either registered trademarks or trademarks of Wi-Fi Alliance®.

Other product names and company names are the trademarks or registered trademarks of their respective companies.

©Seiko Epson Corporation 2022–2026

Table of Contents

■ Safety Precautions	7
Meanings of Symbols	7
Cautions on Installation	7
Cautions on Power Supply.....	7
Cautions on Handling.....	8
Cautions on Ink Cartridges	9
Caution Label.....	10
■ Restriction of Use	12
■ About This Manual	13
Purpose of This Manual.....	13
Manual Organization	13

Product Overview 14

■ Features	14
■ Product Configuration	15
Models.....	15
Accessories	15
Manual Illustrations.....	15
■ Part Names and Functions	16
Front.....	16
Operation Panel.....	18
Rear	19
■ Checking the Product Status	21
Replacement Timing of Consumables.....	21
Statuses and Errors	22
Network Settings Display Mode	26
■ Cut Sheet Processing Modes.....	27
High-speed Mode	27
Confirmation Mode (USB connection only)	29
Speed of Each Processing Mode.....	31
■ NV Memory	33
NV Graphics Memory	33
NV User Memory	33
Memory Switch	33
R/E (Receipt Enhancement)	33
User-defined Page	33
Maintenance Counters.....	34

Setup 35

■ Setup Flow.....	35
-------------------	----

■ Product Installation	36
Removing the Packing Materials	36
Installation	36
■ Connecting a Cash Drawer	37
Specifications Required for a Cash Drawer	37
Connecting the Drawer Cable	38
■ Connecting a Power Supply	39
■ Loading Roll Paper	40
■ Installing the Ink Cartridges	41
■ Connecting to a Host	43
Connecting to an Ethernet LAN	43
Connecting to a Wireless LAN	44
Connecting via USB	45
■ Attaching the Connector Cover	46
■ Adjusting LCD Backlight Brightness	47
■ Checking the Nozzles by Test Printing on Cut Sheets	48

Advanced Product Use **49**

■ Software Settings	49
Function	50
■ Setting/Confirmation Mode	56
Self-test Mode	57
NV Graphics Information Print Mode	59
R/E Information Print Mode	61
Software Setting Mode	62
Printing a Status Sheet (network mode only)	63
Initializing Interface Settings	64
Scanning Demonstration (network mode only)	64
Firmware Update	65

Application Development Information **66**

■ Operating Environment	66
When Connected over a Network	66
When connected via USB	66
■ Driver for Windows Environment	67
■ Web API	68
■ ePOS-Print XML	69
■ Utilities	70
TM-S9000II Utility	70
Epson Deployment Tool	70

BmpToRaster	70
■ Downloading Software	71

Handling the Product **72**

■ Turning On/Off	72
Turning the Power On	72
Turning the Power Off	72
■ Opening a Cover	73
Opening the Ink Cartridge Cover	73
Opening the Roll Paper Cover	73
Opening the MICR Cover, Back Cover, and Scanner Cover.....	74
■ Replacing the Ink Cartridges	75
■ Replacing Roll Paper.....	75
■ Cut Sheet Processing	76
Process Flow.....	76
Loading Cut Sheets	77
Removing Cut Sheets	78
■ ID Card Processing	79
■ Magnetic Stripe Card Processing	80
■ Cleaning the Product.....	81
Cleaning the Exterior	81
Cleaning the Thermal Head and Platen Roller.....	81
Ink Head Cleaning.....	82
Cleaning the Paper Feeding Path.....	82
Cleaning the Scanner	84
■ Preparing for Transport.....	85

Troubleshooting..... **86**

■ The Product Does Not Turn On.....	87
■ Lit or Flashing ! (ERROR) LED.....	87
■ Error Message Displayed on the LCD	87
Automatic Recovery Error	87
Recoverable Error.....	88
Unrecoverable Error	90
■ Cut Sheet Jam	91
■ ID Card Does Not Come Out.....	92
■ Roll Paper Jam	93
■ Cannot Open the Roll Paper Cover	94
■ Problems with Print Quality	95

Printing on Roll Paper Is Blurred	95
Printing on Cut Sheets Is Blurry	95
■ Problems with Reading Quality	95
Cannot Read Magnetic Ink Characters Correctly	95
Poor Cut Sheet or ID Card Reading Quality	95



***Product Specifications*.....96**

■ General Specifications	96
Electrical Specifications	97
Ink Cartridge	97
■ Network Interface Specifications	98
■ USB Interface Specifications	102
USB (Type-B)	102
■ Printing Specifications	103
Roll Paper Printing	103
Cut Sheet Printing.....	104
■ Character Specifications	105
■ Scanner Specifications	106
■ MSR (Magnetic Stripe Reader) Specifications	107
■ Paper Specifications	108
Roll Paper	108
Cut Sheet.....	109
■ Printable Area	110
Roll Paper	110
Cut Sheet.....	111
■ Roll Paper Print Position and Cut Positions	112
■ Scanner Scan Area	113
Cut Sheet.....	113
ID Card.....	114
■ MICR Reading Area	115
■ Electronic Endorsement Area	115
■ Environmental Specifications	116
■ Reliability	117
■ Overall Dimensions	118
■ Character Code Tables	119

Safety Precautions

Meanings of Symbols

The symbols explained below are used in this manual. Be sure to take the time to understand the meaning of each symbol before using the product.

 WARNING	Handling the product improperly by ignoring this symbol can lead to death or serious injury.
 CAUTION	Ignoring this symbol and using the product improperly can lead to the problems listed below. <ul style="list-style-type: none">• Personal injury• Material damage• Loss of data and other information
CAUTION	Indicates information with which you must comply when using the product. Mishandling due to ignoring this information may cause the product to fail or malfunction.
NOTE	Indicates supplementary explanations and information you should know.

Cautions on Installation

 CAUTION	<ul style="list-style-type: none">❑ Do not install/store the product in an unstable location or in a location subject to vibration from other devices. Equipment may fall or collapse, causing breakage and possible injury.❑ Do not install the product in a location exposed to oily smoke or dust, or in a humid location. Doing so may cause electric shock or fire.❑ Use the product under the environmental conditions specified in the manual. (“Environmental Specifications” on page 116)
---	--

Cautions on Power Supply

 WARNING	<ul style="list-style-type: none">❑ Do not use other than the specified AC adapter. In addition, do not use the specified adapter with another device. Doing so may cause electric shock or fire.❑ Observe the following points when handling the AC adapter. Doing so may cause electric shock or fire.<ul style="list-style-type: none">* Do not use in a location where rain or water will get on the AC adapter.* Do not suspend the product by the power cord.* Do not allow a clip or other metal object to touch the connectors.* Do not cover with bedding.❑ Do not allow dust or other foreign material to adhere to the power plug. Doing so may cause electric shock or fire.❑ Insert the power plug securely all the way into the outlet. Doing so may cause electric shock or fire.❑ Be sure your AC power cord meets relevant safety standards of the area where you plan to use it.❑ Do not use a damaged power cable. Doing so may cause electric shock or fire.
---	--



- ❑ **Contact qualified service personnel for advice if the power cable is damaged. Furthermore, observe the following points so as not to damage the power cable.**
 - * Do not modify the power cable.
 - * Do not place heavy objects on the power cable.
 - * Do not forcibly bend, twist, or pull the power cable.
 - * Do not lay the power cable near a heating appliance.
- ❑ **Do not insert or remove the power plug with a wet hand. Doing so may cause electric shock.**
- ❑ **Do not connect many power cables to one outlet. Doing so may cause fire.**
- ❑ **Regularly disconnect the power plug from the outlet and clean the base of the prongs and between the prongs. Leaving the power plug connected to the outlet for a long period of time may cause dust to accumulate on the base of the power plug prongs, resulting in a short and fire.**
- ❑ **Hold the plug and do not pull the cable when disconnecting the power plug from the outlet. Pulling the cable may damage the cable or deform the plug, causing electric shock or fire.**



- ❑ To ensure safety, unplug the product before leaving it unused for an extended period.

Cautions on Handling



- ❑ **Do not use the product in a location with volatile substances such as alcohol or paint thinner present, or near fire. Doing so may cause electric shock or fire.**
- ❑ **Shut down the product immediately if it produces smoke, a strange odor, or unusual noise. Doing so may cause electric shock or fire. If an abnormality occurs, immediately turn off the power and remove the plug from the outlet, and then contact qualified service personnel for advice.**
- ❑ **Shut down the product immediately if a foreign object or water or other liquid gets inside the product. Continued use may cause electric shock or fire. Immediately turn off the power and remove the plug from the outlet, and then contact qualified service personnel for advice.**
- ❑ **Never disassemble or repair the product by yourself as doing so is dangerous.**
- ❑ **Do not use the product in a location where inflammable gas, explosive gas, etc. is present in the atmosphere. Furthermore, do not use aerosol sprayers containing flammable gas inside or around the product. Doing so may cause fire.**
- ❑ **Do not connect cables in ways other than those mentioned in this manual. Doing so may cause fire. It may also damage the other connected devices.**
(“Connecting a Power Supply” on page 39, “Connecting to a Host”)
- ❑ **Do not touch the areas inside the product other than those mentioned in this manual. Doing so may cause electric shock or burns.**
- ❑ **Do not insert metal or flammable materials, or allow them to fall into the product. Doing so may cause electric shock or fire.**



- ❑ Do not allow anyone to stand or place heavy objects on top of the product. Equipment may fall or collapse, causing breakage and possible injury.
- ❑ Install the cables and optional products in the proper direction according to the proper procedures. Failure to do so creates the risk of fire or electric shock. Follow the instructions in this manual to install them properly.
(“Connecting a Power Supply” on page 39, “Connecting to a Host”)
- ❑ Before moving the product, shut down and unplug the product, and make sure that all the cables are disconnected. Failure to do so may damage a cable, causing electric shock or fire.
- ❑ Do not store or transport the product while it is tilted, standing, or upside down. Doing so may cause the ink to leak.

CAUTION

If this product is used in a place where silicon-based gases including siloxane (silicon adhesive, silicon oil, silicon powder, etc.) or malignant gases (nitric acid, hydrogen sulfide, ammonia, chlorine, etc.) are present in the air, contact failure may occur in mechanical contacts such as mechanical switch or DC motor in a short time due to adhesion or oxidation of the insulation film.

Cautions on Ink Cartridges



- ❑ Do not touch the IC chip on an ink cartridge. Doing so may result in normal operation and printing becoming no longer possible.
- ❑ The product uses ink cartridges equipped with IC chips to manage the amount of ink used and other information so ink cartridges are usable even if they are removed and reinstalled. However, if an ink cartridge with not much ink remaining is removed and reinstalled, it may not be usable. Some ink is consumed each time cartridges are installed because the product automatically checks their reliability.
- ❑ Since ink cartridges are designed to stop the operation before ink runs out completely to maintain the quality of the ink head, some ink remains in the used ink cartridges.
- ❑ In order to keep the ink head in good condition, ink is also consumed during such non-printing maintenance operations such as ink cartridge replacement.
- ❑ Do not turn off the power or open the cover during ink charging (while the  (Power) LED is flashing). Opening the cover may cause the ink to be recharged, resulting in more ink being consumed. Also, it may result in normal printing becoming no longer possible.
- ❑ Do not disassemble an ink cartridge. Doing so may cause ink to get into eyes or onto skin.
- ❑ Do not disassemble or modify an ink cartridge. Doing so may cause printing malfunction.
- ❑ Use of old ink cartridges may result in reduced print quality. Use ink cartridges up within six months after opening the packages. The usage period for ink cartridges is printed on the packaging of the individual ink cartridges.



- ❑ If ink contacts your skin, eyes, or mouth, take the following actions.
 - * When ink gets onto your skin, immediately wash the area with soap and water.
 - * When ink gets into your eyes, immediately flush them with water. Leaving the ink as is may result in bloodshot eyes or mild inflammation. If something is wrong, immediately consult with a doctor.
 - * When ink gets into your mouth, immediately spit it out and consult with a doctor.
- ❑ There may be some ink around the ink supply port on a removed ink cartridge. Take care so that it does not stain the desk or other surface.
- ❑ Do not remove the ink cartridge except to replace it.
- ❑ Do not open an ink cartridge package until you are ready to install the ink cartridge in the product.
- ❑ Do not shake an ink cartridge too hard. The ink cartridge may leak if you shake it around too much or push the sides strongly.
- ❑ Do not allow foreign objects to fall into the cartridge installation section. Doing so may result in normal printing becoming no longer possible. Remove any object that falls into the installation section, taking care not to damage the section.
- ❑ When ink is charged the first time (right after purchase), ink is consumed for filling the ink head nozzles (ink discharge holes) to get ready for printing. Because of this, the number of sheets that can be printed by the first ink cartridge used in a new product may be lower than that of the second and subsequent ink cartridges.
- ❑ Turning off the product by performing a  (POWER) button operation or by sending a command causes the ink head to be capped automatically to prevent the ink from drying. If you do not plan to use the product after installing an ink cartridge, be sure to use either of the methods above to turn off power. Do not pull out the power plug or turn off the breaker while the power is on.
- ❑ Printing on water-repellent paper such as art paper, which is slow-drying, may cause print stains. Also, if you print on glossy paper, fingerprints may get on the paper or ink may adhere to your fingers when you touch the print surface. Select and use paper that will not cause print stains.
- ❑ Store the ink cartridges in a place out of reach of children.
- ❑ Epson recommends storing ink cartridges in a cool and dark place.
- ❑ If you wish to use ink cartridges that have been stored in a cold place for a long period of time, leave them for at least 3 hours in a place that is at room temperature before use.
- ❑ Do not remove the ink cartridges from the product when storing the product.

Caution Label

The labels affixed to the product indicate the following cautions.



Do not touch the thermal head during or immediately after use. They may be very hot after a print operation.

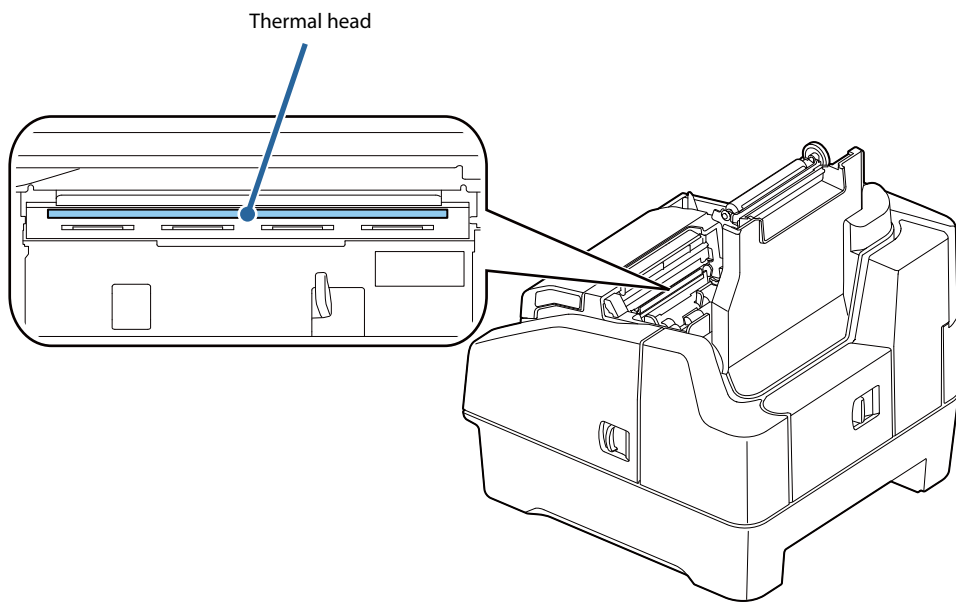

Restriction of Use

When this product is used for applications requiring high reliability/safety such as transportation devices related to aviation, rail, marine, automotive etc.; disaster prevention devices; various safety devices etc.; or functional/precision devices etc., you should use this product only after giving consideration to including fail-safes and redundancies into your design to maintain safety and total system reliability.

This product is not intended for use in aerospace equipment, main communication equipment, nuclear power control equipment, medical equipment, or other applications that require a very high level of reliability and/or safety. Be sure to check with the customer concerning these applications and judge applicability accordingly.

About This Manual

Purpose of This Manual

This manual is intended to provide development engineers with information about product functions, operations, maintenance, and troubleshooting, and the information needed for application development and design.

Manual Organization

This manual is organized as shown below.

- Chapter 1 [Product Overview](#)
- Chapter 2 [Setup](#)
- Chapter 3 [Advanced Product Use](#)
- Chapter 4 [Application Development Information](#)
- Chapter 5 [Handling the Product](#)
- Chapter 6 [Troubleshooting](#)
- Chapter 7 [Product Specifications](#)

Product Overview

This chapter describes the features and functions of the product.

Features

This product is a compact multifunction device that incorporates various functions required by banking counter services.

- ❑ Roll paper printing
 - Auto cutter as standard
 - Roll Paper Reduction
- ❑ Cut sheet (check endorsement, single receipt, cashier's check) printing
360-nozzle inkjet printing enables 180 dpi multi-line, high-resolution output [dpi: dot per inch]
- ❑ Check magnetic ink character recognition ^{*1}
- ❑ Cut sheets, personal ID (driver's license) two-side data acquisition
Binary (cut sheets only), gray scale, color, IR (infrared) image acquisition
- ❑ Auto sheet feeder that automatically feeds cut sheets one sheet at a time
 - Cut sheet multi-feed detector
 - Check mis-insertion detector
 - Image quality assessment (IQA) (supported by driver) ^{*1}
 - Optical character recognition (OCR) (supported by driver) ^{*1 *2}
- ❑ Magnetic Stripe Reader (MSR) ^{*3}
- ❑ LCD for quick and easy understanding of product status and network settings
- ❑ Equipped with High-Speed USB (USB 2.0) and Ethernet interfaces. Wi-Fi is also available with the optional OT-WL06.
- ❑ Equipped with an interface selection switch (physical switch)
 - USB connection (compatible with the API for TM-S9000II-MJ)
 - Network connection (with built-in Epson Web API)
- ❑ Drawer connection allowed
- ❑ Counter that comes in handy for remote maintenance
- ❑ Built-in buzzer
- ❑ Ink Cartridge
Equipped with a low ink detection function and an ink cartridge replacement request notification function.
- ❑ Security
Supports WPA3-SAE including WPA-Enterprise
- ❑ Printing receipts can be controlled using ePOS Print
- ❑ Port 9100 is supported
Can be controlled over a network from conventional printing applications
- ❑ A connector cover is included as standard to protect the optional OT-WL06 from theft

*1: These functions are supported by the printer driver when the product is connected via USB, and by the product itself when the product is connected over a network.

*2: Supported fonts are OCR-A and OCR-B only

*3: Depends on model

Product Configuration

Functions and accessories for this product depend on the model.

Models

- Model without MSR (Magnetic Stripe Reader)
- Model with MSR

Accessories

- Roll paper (for initial trial operation)
- Special ink cartridge SJIC18(K) x 2
- Dedicated AC adapter; "AC Adapter V"
- USB cable (length: 170 cm, color: black)
- AC cable*
- Connector cover
- Instruction manuals

Manual Illustrations

Unless specifically indicated otherwise, all illustrations in this manual show a model equipped without MSR.

Part Names and Functions

Front

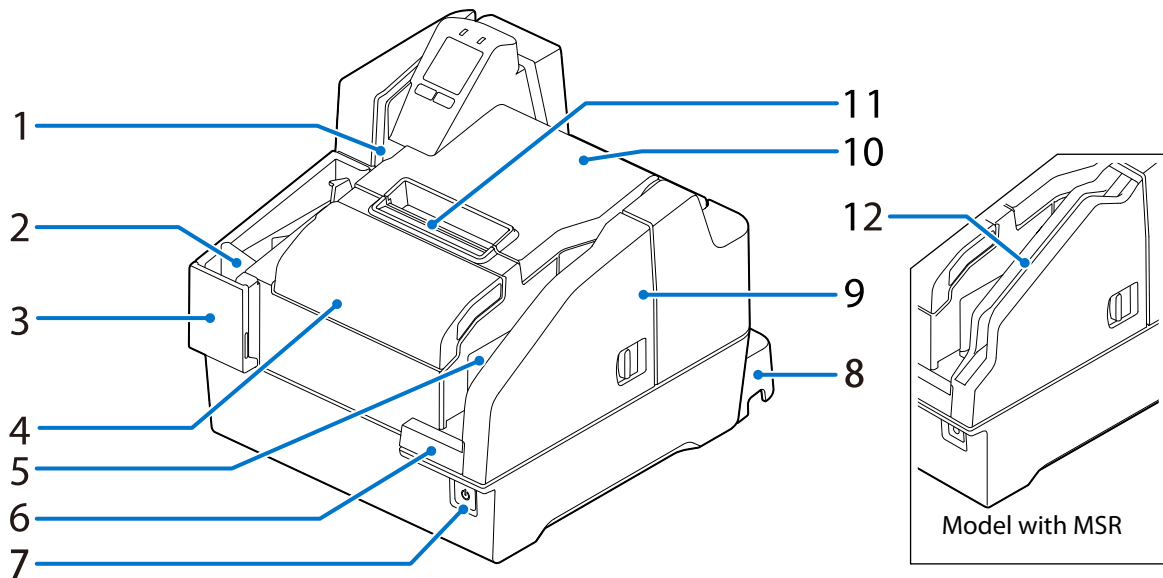

1	ID card slot
To read an ID card, insert it. ("ID Card Processing" on page 79)	
2	Main pocket
Pockets hold cut sheets ejected after processing.	
3	Pocket guides
Pull out the pocket guide to match the length of the cut sheets being used.	
4	Ink cartridge cover
Open this cover to install/replace the ink cartridge. ("Installing the Ink Cartridges" on page 41 , "Replacing the Ink Cartridges" on page 75)	
5	ASF (Auto-Sheet-Feeder)
Set checks or cut sheets here to scan them. Up to 100 sheets can be set at a time. ("Cut Sheet Processing" on page 76)	
6	ASF guide
Pull out the pocket guide to match the length of the cut sheets being used.	
7	 (POWER) button
Turn the product on/off. ("Turning On/Off" on page 72)	

8	Connector cover	Use the printer with this cover attached to protect cables.
9	MICR cover	Open this cover if cut sheets become jammed. (“Opening the MICR Cover, Back Cover, and Scanner Cover” on page 74 , “Cut Sheet Jam” on page 91)
10	Roll paper cover	Open this cover to load or replace the roll paper. (“Loading Roll Paper” on page 40 , “Replacing Roll Paper” on page 75)
11	Manual cutter	This cutter is for manually cutting roll paper.
12	MSR (Magnetic Stripe Reader)	To read a magnetic stripe card, insert the card and slide it. (“Magnetic Stripe Card Processing” on page 80)

Operation Panel

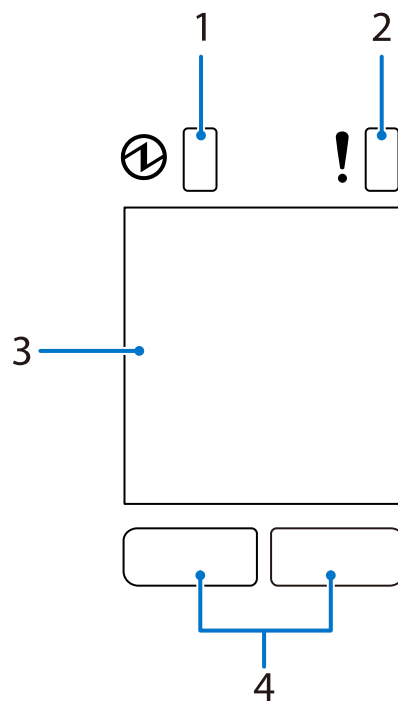

1	⚡ (POWER) LED
Lights when the product is turned on. Flashes during printing and while ink is charging.	
2	! (ERROR) LED
Lights when an error occurs. ("Checking the Product Status" on page 21)	
3	LCD
Shows the status of consumables and the product. ("Checking the Product Status" on page 21) LCD backlight brightness is adjustable. ("Adjusting LCD Backlight Brightness" on page 47)	
4	Button 1 (Left) / Button 2 (Right)

Each button is assigned the corresponding function that appears at the bottom of the LCD. The function on the lower left of the LCD is executed when Button 1 (left button) is pressed, while the function on the lower right is executed when Button 2 (right button) is pressed.

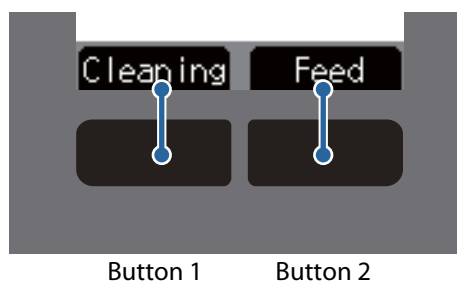

Rear

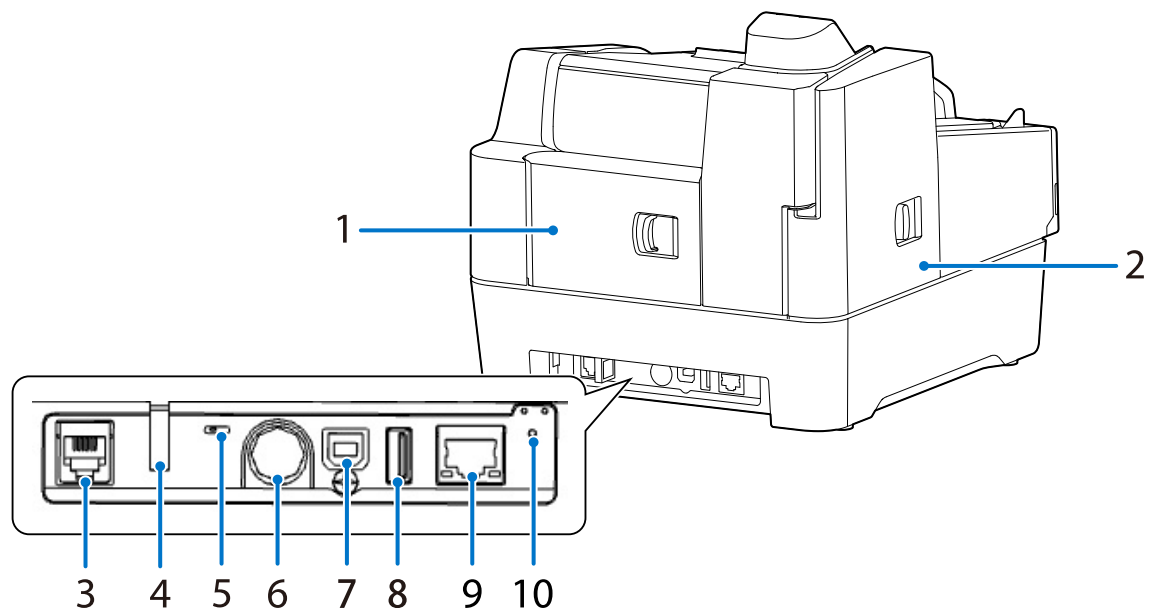

1	Back cover
	Open this cover if cut sheets become jammed. (“Opening the MICR Cover, Back Cover, and Scanner Cover” on page 74, “Cut Sheet Jam”)
2	Scanner cover
	Open this cover if cut sheets or an ID card becomes jammed. (“Opening the MICR Cover, Back Cover, and Scanner Cover” on page 74, “Cut Sheet Jam”, “ID Card Does Not Come Out”)
3	Drawer kick connector
	Connect the drawer cable.
4	Wire saddle
	Pass the USB cable through this saddle to prevent disconnection of the cable.
5	Interface selection switch
	Slide the switch to either left or right to switch between network connection mode and USB connection mode. The default position is the left (network connection mode). (“Connecting to a Host” on page 43)
6	DC-IN connector
	Connect a DC cable.
7	USB connector (Type B)
	Connect a USB cable (Type B).
8	USB connector (Type A)
	Connect the optional wireless LAN unit (OT-WL06).

9	Ethernet connector
---	--------------------

Connect a LAN cable.

10	Status sheet button
----	---------------------

Press this to print a status sheet. (["Printing a Status Sheet \(network mode only\)"](#) on page 63)

Checking the Product Status

The status of the product can be checked from a combination of the LEDs lighting/flashing and the LCD display.



NOTE

The error type cannot be distinguished by the LED pattern. Develop an application that reads the status from the application and identifies the error, and lets the user know the required recovery procedure.

Replacement Timing of Consumables

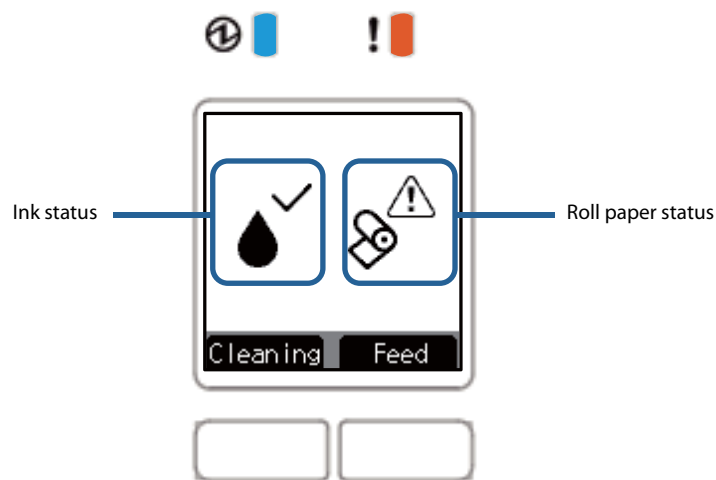
The ink cartridge and roll paper status can be checked on the LCD home screen.



LCD display	Status
	<ul style="list-style-type: none"> There is sufficient ink remaining. There is sufficient roll paper remaining.
	<ul style="list-style-type: none"> There is not much ink remaining so nearly time to replace the ink cartridge. Prepare a new ink cartridge. Roll paper is low, and the time to replace the roll paper is approaching. Prepare new roll paper.
	<ul style="list-style-type: none"> Ink cartridge is expended. Loading or replacement of the ink cartridge is required. Printing on cut sheet is not possible until a new ink cartridge is installed. Ink cartridge replacement guidance appears on the LCD. (“Replacing the Ink Cartridges” on page 75) Roll paper is not loaded or remaining roll paper is low. To print on roll paper, loading or replacement of the roll paper is required. Printing on roll paper is not possible until new roll paper is loaded. Ink roll paper replacement guidance appears on the LCD. (“Replacing Roll Paper” on page 75)

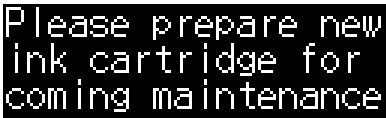









LCD display	Status
	An ink cartridge is not installed. An ink cartridge must be loaded to print on cut sheets.
	There is not enough ink for periodic ink head cleaning. The ink cartridge needs to be replaced to perform cleaning.



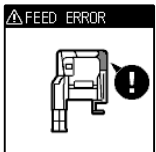

















Statuses and Errors

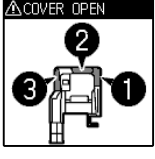

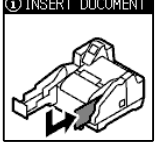

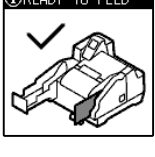

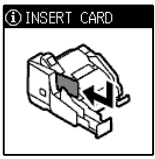

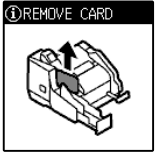









The status of the product can be checked from a combination of the LEDs lighting/flashing and the LCD display.





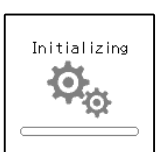









Product operation stops when an error occurs. For details on resolving errors, refer to [“Error Message Displayed on the LCD”](#) on page 87.

 :Off  :On  :Flashing

LED		LCD display	Product status
 POWER	 ERROR		
			Cut sheets are jammed in the MICR reader. (“Cut Sheet Jam” on page 91)
			Cut sheets are jammed in the back of the product (“Cut Sheet Jam” on page 91)
			Cut sheets are jammed in the scanner (“Cut Sheet Jam” on page 91)

LED		LCD display	Product status
POWER 	ERROR 		
			The roll paper cover is open
			Auto cutter position error ("Recoverable Error" on page 88)
			Ink cover is open
			One or more of the following covers are open: MICR cover, back cover, scanner cover
			Standing by for insertion of cut sheets
			Cut sheet detection
			Card insertion standby
			Card removal standby

LED		LCD display	Product status
POWER 	ERROR 		
	<input type="checkbox"/>		Cartridge loading or replacement required ("Installing the Ink Cartridges" on page 41)
	<input type="checkbox"/>		Roll paper loading or replacement required ("Loading Roll Paper" on page 40)
	<input type="checkbox"/>		Ink head cleaning standby ("Ink Head Cleaning" on page 82)
	<input type="checkbox"/>		Ink head cleaning
			<ul style="list-style-type: none"> Thermal head high temperature Ink head high temperature Motor driver high temperature ("Automatic Recovery Error" on page 87)
	<input type="checkbox"/>		<ul style="list-style-type: none"> In power-on sequence In power-off sequence
	<input type="checkbox"/>		Firmware rewriting (data receive in progress)
	<input type="checkbox"/>		Firmware rewriting (data writing, restoration in progress)

LED		LCD display	Product status
POWER	ERROR		
			Macro execution function operation standby
			The pump unit is near the end of its service life
			Unrecoverable error ("Unrecoverable Error" on page 90)
		  	Insufficient ink for periodic ink head cleaning

Network Settings Display Mode

You can display the network settings on the screen by pressing Button 1 and Button 2 at the same time for two seconds.

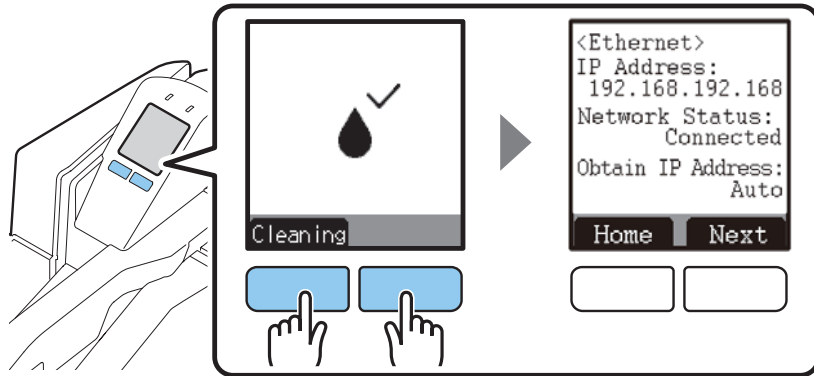

Network mode (Ethernet)

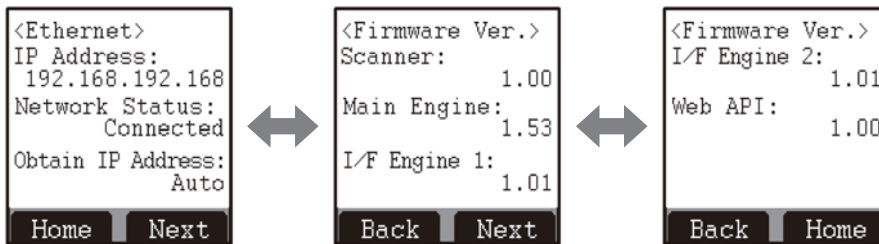

Network mode (Wi-Fi)

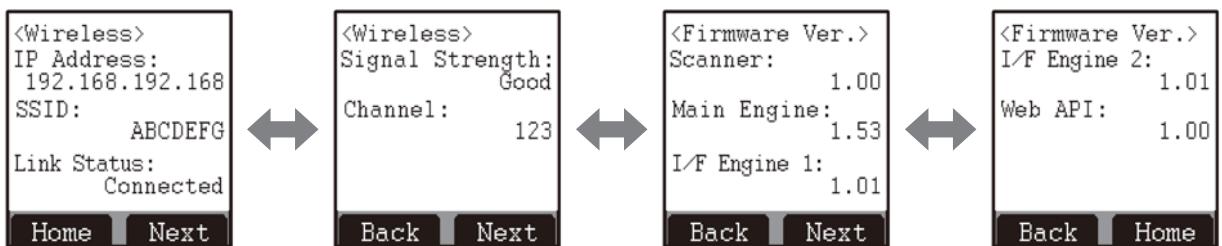

Cut Sheet Processing Modes

There are two modes for processing cut sheets. Select the method most suitable for your environment.

- High-speed mode (“[High-speed Mode](#)” on page 27)
- Confirmation mode (“[Confirmation Mode \(USB connection only\)](#)” on page 29)

For details on processing modes, refer to the *TM-S9000MJ API Reference Guide*.

High-speed Mode

Use this mode to specify processing conditions from the firmware or driver.

Table of Judgment Subjects and Criteria

When connected over a network

Judgment made by:	Criteria
Firmware	<ul style="list-style-type: none"> • Overlapping feeding detection result • Incorrect insertion detection result (Check paper) • Magnetic waveform detection result • External noise detection result • Printing result of exceeded media length • MICR “?” detection result • IQA judgment result • Barcode recognition result

When connected via USB

Judgment made by:	Criteria
Firmware	<ul style="list-style-type: none"> • Overlapping feeding detection result • Incorrect insertion detection result (Check paper) • Magnetic waveform detection result • External noise detection result • Printing result of exceeded media length
Driver	<ul style="list-style-type: none"> • MICR “?” detection result • IQA judgment result • Barcode recognition result

Document Processing Sequence

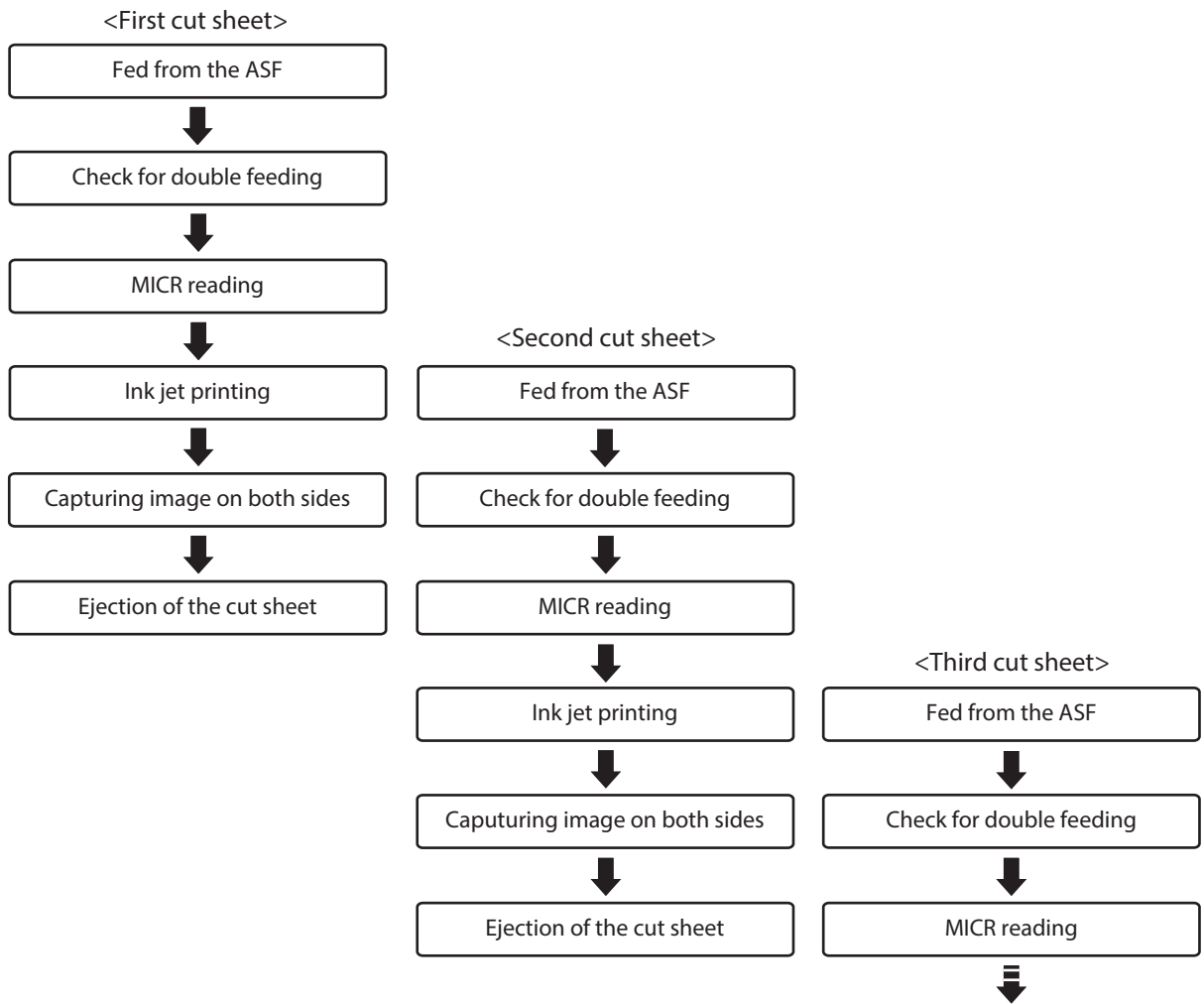

Confirmation Mode (USB connection only)

Use this mode to specify processing conditions from the application.

This mode stops the process that starts with cut sheet feeding from the ASF and ends with cut sheet output to a pocket, in order to receive an instruction from the application. It then restarts the process. It also can be used to configure the no-overlap/overlap setting from the application.

NOTE

No-overlap: Starts send of the next cut sheet after the current cut sheet is fully in the pocket

Overlap: Starts feeding of the next cut sheet while the current cut sheet is being output to the pocket

Document Processing Sequence

The processing sequence changes depending on whether there is overlap operation or not.

With overlap

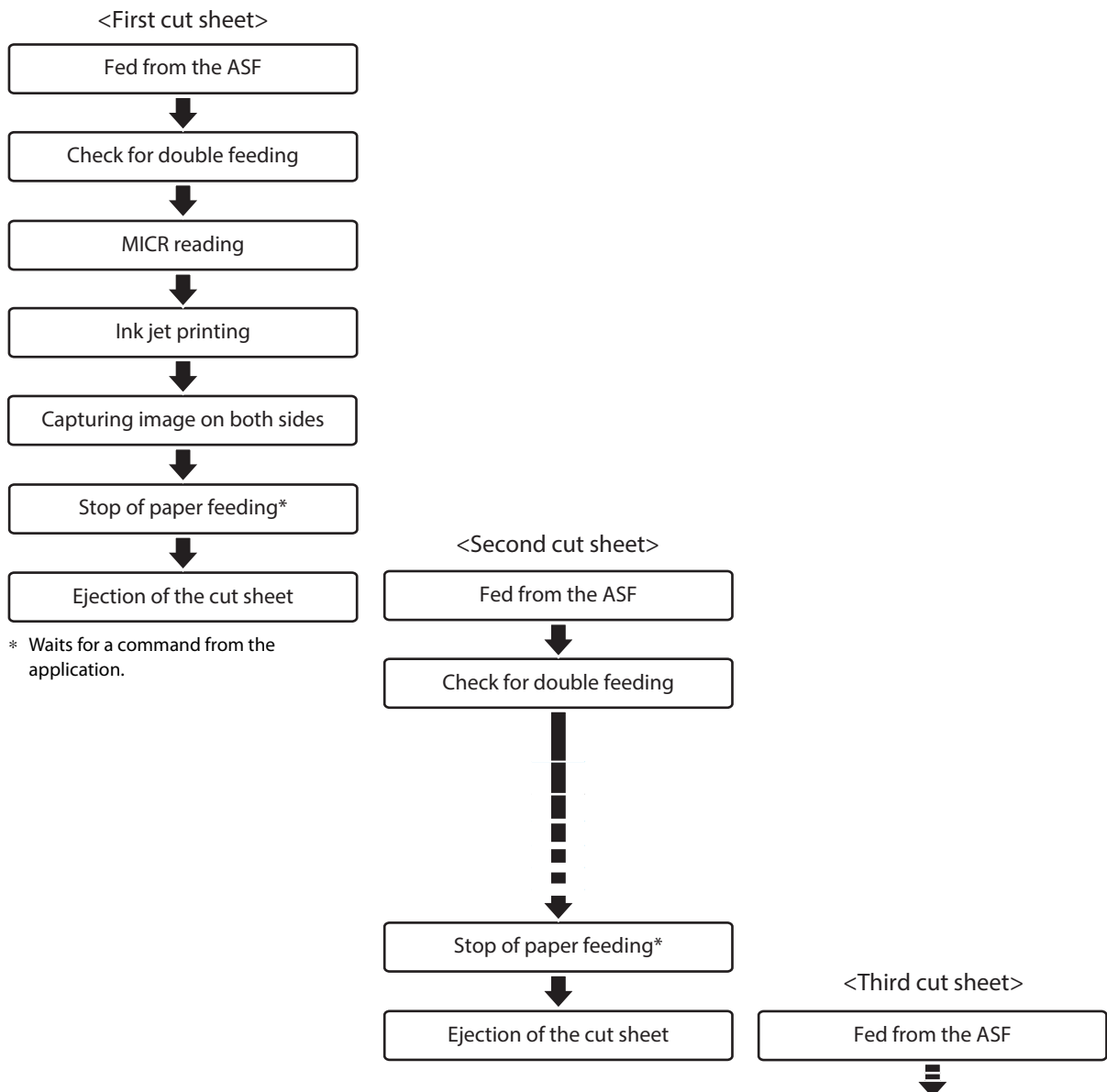

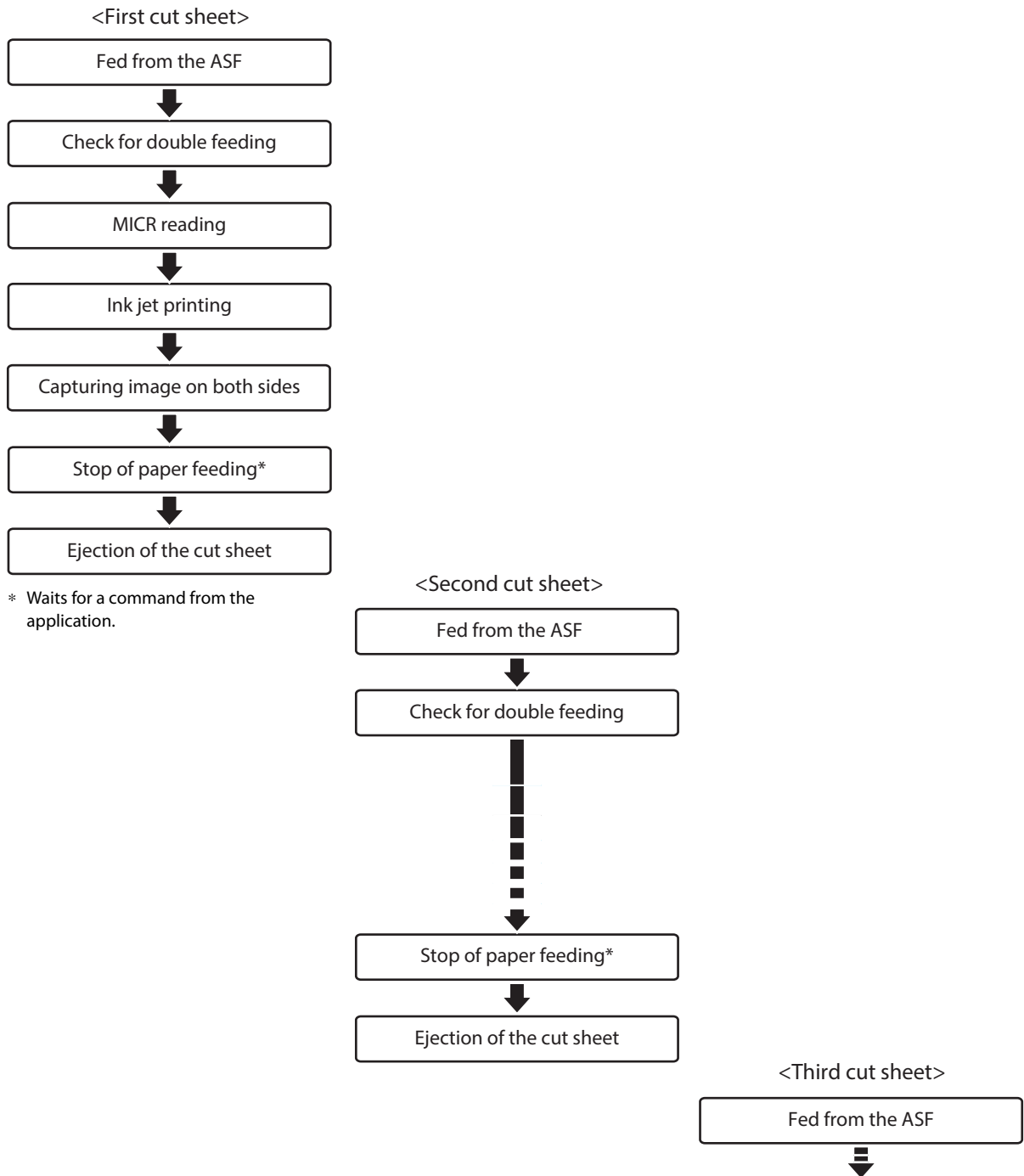
Without overlap

Speed of Each Processing Mode

Processing Speed Conditions

The processing speed may be reduced by the conditions described below.

- Host computer operating environment (“[Operating Environment](#)” on page 66)
- Software that coexists on the computer
- Image resolution, light source settings
When the resolution of the captured image is 240 dpi or 300 dpi, or when the acquired image is 24-bit color or infrared (IR)
- Driver IQA, OCR, bar code recognition settings
- Data transfer, save, and other application processing
- Cut sheet status
- Processing mode and judgment subject
- Network environment

Connection	Processing modes	Judgment made by	Condition details
Network connection (Web API)	High-speed mode	Firmware	Operation based on firmware judgments, without instruction from Web applications, for high-speed processing.
USB connection (PC API)	High-speed mode	Firmware	Operation based on firmware judgments, without instruction from the host computer, for high-speed processing.
		Driver	When driver judgment is required, processing speed is slower compared to operation according to judgment conditions by firmware only.
	Confirmation mode	Application	Since the product stands by for instructions from the application for each cut sheet scan, processing speed depends on control from the application. Also, processing speed depends on whether or not overlap is performed.

Processing Speed When Connected Over a Network

The processing speeds in the case of a network connection shown in the following table are the speeds (maximum values) from the time the first cut sheet is sent out from the ASF to the time the HTTP communication library of the host terminal completes receiving the image data of the 100th cut sheet.

Resolution of captured image: 200 dpi

Processing mode	Media size	Color	Spec speed: 200 DPM ^{*1*2}
			Main-pocket ejection
High-speed mode	Personal check	Black and White	200 DPM
	Business check	Black and White	180 DPM
	Personal check	Grayscale	170 DPM
	Business check	Grayscale	160 DPM

*1: Processing speed when connected via a wired LAN (10BASE-T/Full duplex or higher) and when the network environment is not overloaded

*2: Processing speed is lower when connected via wireless LAN compared to a wired LAN connection.

Processing Speed When Connected via USB

The processing speeds in the case of a USB connection shown in the following table are the speeds (maximum values) from the time the first cut sheet is sent out from the ASF to the time the PC application completes receiving the image data of the 100th cut sheet.

Resolution of captured image: 200 dpi, grayscale/black and white

Processing mode	Media size	Spec speed: 225 DPM
		Main-pocket ejection
High-speed mode Firmware judgment	Personal check	225 DPM
	Business check	175 DPM
High-speed mode Driver judgment	Personal check	79 DPM
	Business check	65 DPM
Confirmation mode ^{*1} Application judgment	Personal check	66 DPM
	Business check	52 DPM

*1: Does not take PC application processing time into consideration

NV Memory

This product is equipped with nonvolatile memory (NV), which maintains stored data even if the product is turned off. The memory areas below are available in NV memory for use by the user.

- NV graphics memory
- NV user memory
- Memory switch
- R/E (receipt enhancement)
- User-defined page
- Maintenance counters

CAUTION

As a general rule for the number of writes to NV memory, create an application that writes no more than 10 times a day.

NV Graphics Memory

Multiple store logos and other graphics can be registered for printing on logos.

Registered graphics can be viewed using the TM-S9000II Utility or the NV graphics information print mode.

NOTE

For details on the NV graphics information printing mode, refer to the TM-S9000II Utility User's Manual and [“NV Graphics Information Print Mode” on page 59](#).

NV User Memory

Custom product settings and maintenance information can be saved as text data and read as required.

Memory Switch

This switch can be used to configure various product settings.

For details on memory switches, refer to [“Software Settings” on page 49](#).

R/E (Receipt Enhancement)

Settings can be configured to have the store logo and other graphics printed automatically at the beginning and the end of receipts.

For details on R/E (receipt enhancement), refer to [“R/E Information Print Mode” on page 61](#).

User-defined Page

Character that is not registered on the product can be printed by registering it on a user-defined page (Character Code Table: page 255).

Maintenance Counters

This function automatically registers the number of print lines, the number of auto cutter operations, product running time, and other maintenance counter information in product memory. Counter information can be referenced to support periodic inspections, consumable replacement and others.

NOTE

The head travel distance and the number of auto cutter operations ("[Self-test Mode](#)" on page 57).

Setup

This chapter describes the product and peripheral device installation and setup procedures that need to be performed before using the product.

Setup Flow

The information in this chapter follows the flow of product and its peripheral device setup as shown below.

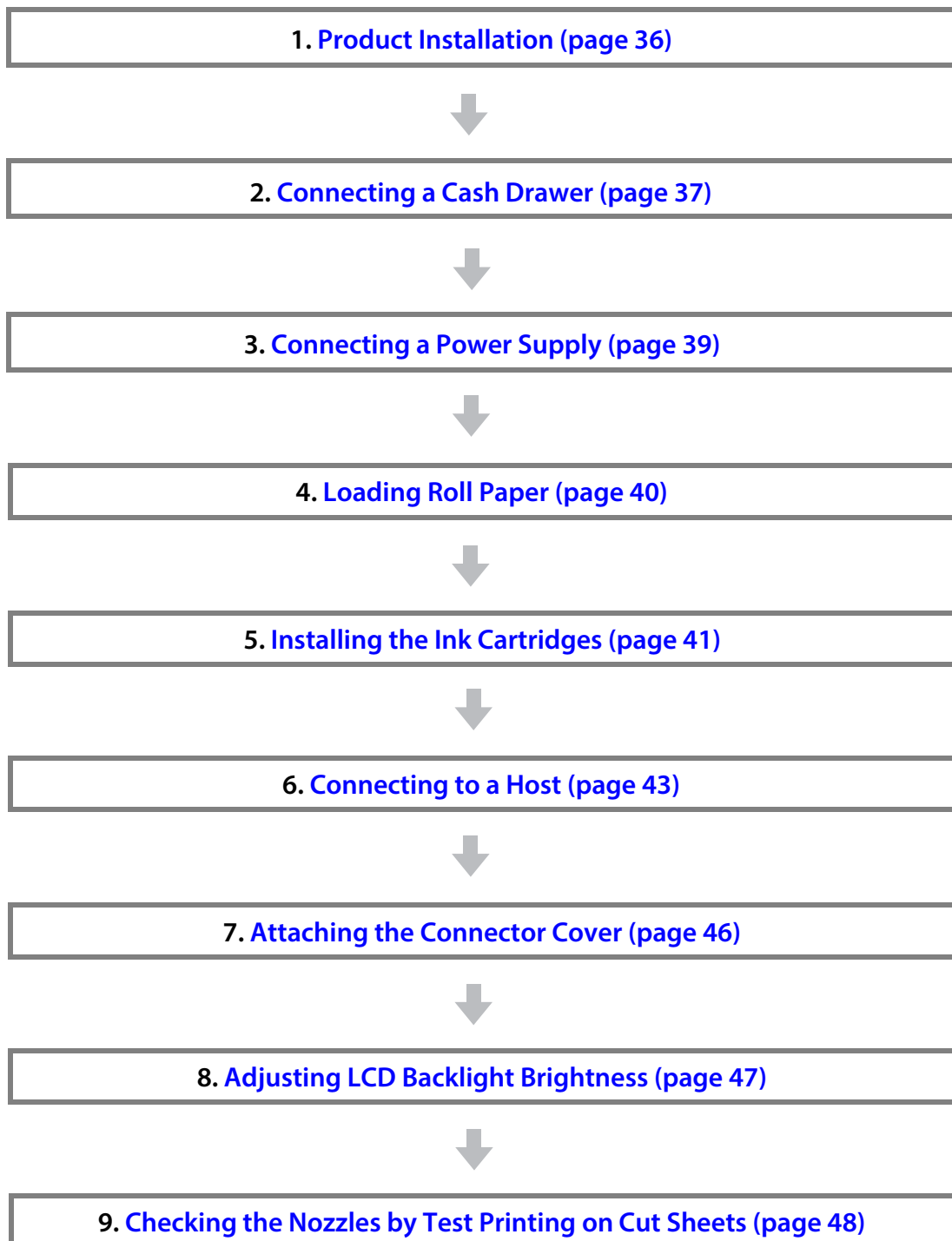

Product Installation

Removing the Packing Materials

Packing materials are affixed for protection against shock during transportation. Remove the packing materials shown below before installing the product.

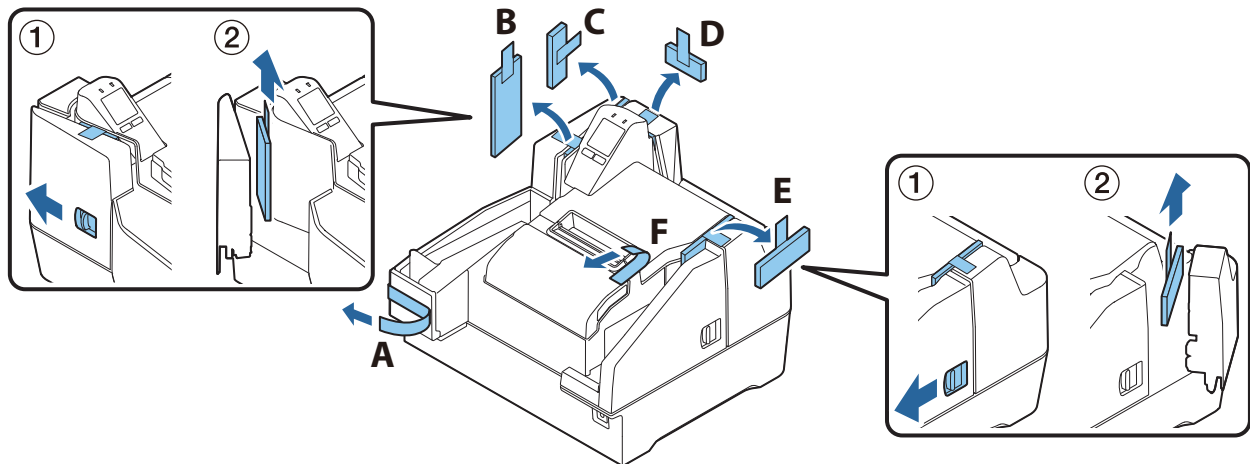

NOTE

The packing materials and packaging box are required for future transportation. Keep them in a safe place.

Installation

Provide sufficient space in a location appropriate for installation.

Location Appropriate for Installation

- On an area larger than the bottom surface of the product (“[Overall Dimensions](#)” on page 118)
- In a level and stable location
- In a location free of vibration and impacts
- In a location where a dedicated power outlet is available
- In a location with sufficient space around the product to allow for replacement of consumable products, and daily cleaning.
- In a location meeting the guaranteed environmental conditions (“[Environmental Specifications](#)” on page 116)

CAUTION

- When moving the product, lift it up by grasping at the depressions on either side.
- Make sure that cords or other objects are not being pinched by the product.
- To avoid deterioration of the MICR recognition rate, do not install the product near a magnetic field. In particular, check the MICR reader recognition rate when the product is installed near a display device.

Connecting a Cash Drawer

CAUTION

- Simultaneous operation of two drives is not supported.
- When sending consecutive drawer drive pulses, allow an interval between pulses that is at least four times that of the drawer drive pulse.

Specifications Required for a Cash Drawer

Cash drawer specifications vary widely according to manufacturer and model. Whenever connecting a drawer that is not one specified for this product, check to make sure that it meets the drawer specifications below. Connecting a drawer that does not meet these specifications creates the risk of damage to the product.

- Drawer kick solenoid or other load between pins 4 and 2 or pins 4 and 5 of the drawer kick connector
- When using a drawer open/close signal, a switch must be provided between drawer kick connector pins 3 and 6
- Load resistance (by a drawer kick solenoid or others) of at least $24\ \Omega$, and input current of no more than 1 A
- Use of only the 24 V output of drawer kick connector pin 4 for the drawer power supply

Drawer Kick Connector Connection Diagram

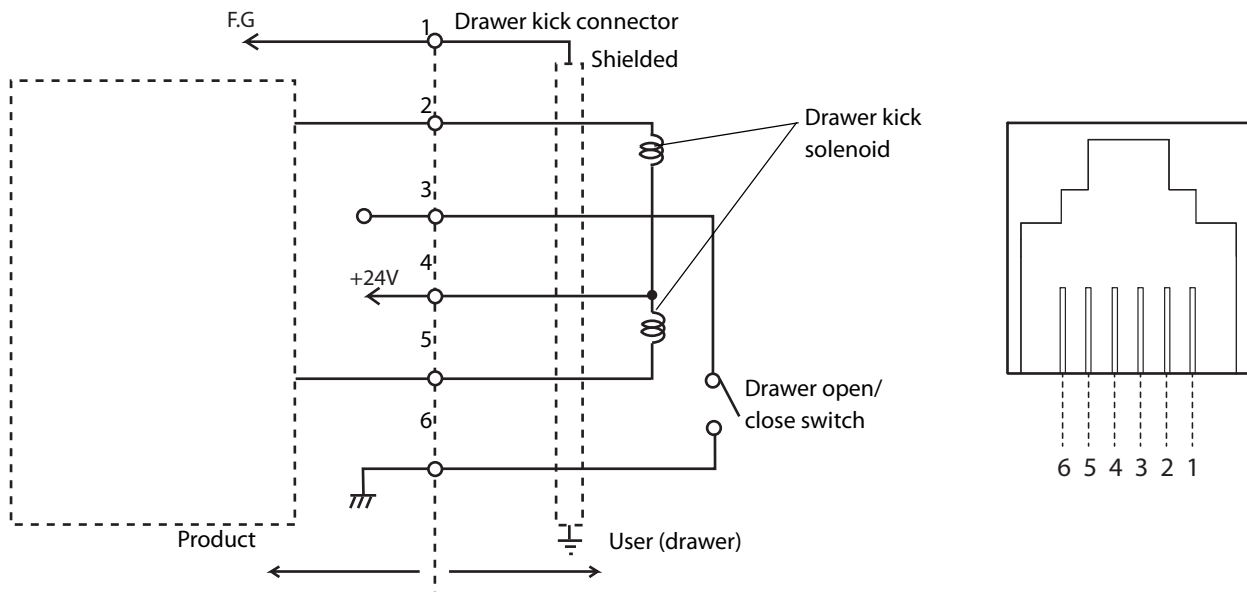

Connecting the Drawer Cable



- Use a shielded cable for the drawer cable.
- Be sure to use product power (connector pin 4) for drawer power.
- Do not plug a general public phone line or other similar connector to the drawer kick connector. Doing so can damage the public phone line or product.

Insert the drawer cable into the product's drawer kick connector until you hear it click into place.

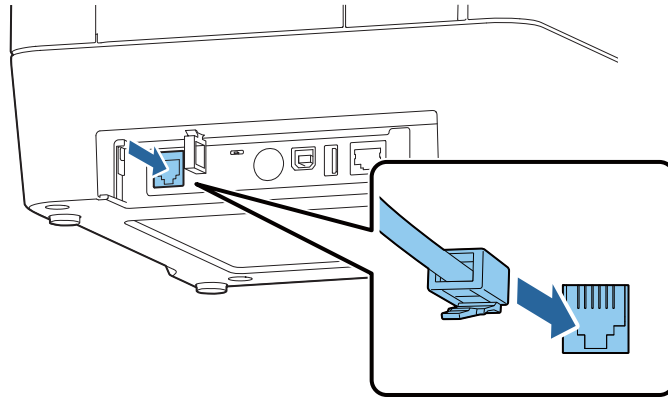

Connecting a Power Supply



- Use only the specified AC adapter. Not doing so may cause a fire or electric shock. (“[Electrical Specifications](#)” on page 97)
- Do not plug the AC cable into a power outlet whose voltage does not match the input voltage of the AC adapter. Doing so can damage the product.
- If you discover an abnormality immediately turn off the product and unplug AC cable from the power outlet.
- Use only the AC cable that comes with the product.

- 1** Insert the DC connector of the AC adapter firmly all the way into the DC-IN connector of the product.
- 2** Insert the connector of the AC cable firmly all the way into the AC inlet of the AC adapter.
- 3** Insert the power plug firmly all the way into an outlet with a ground.
- 4** Place the AC adapter with its label facing downward.

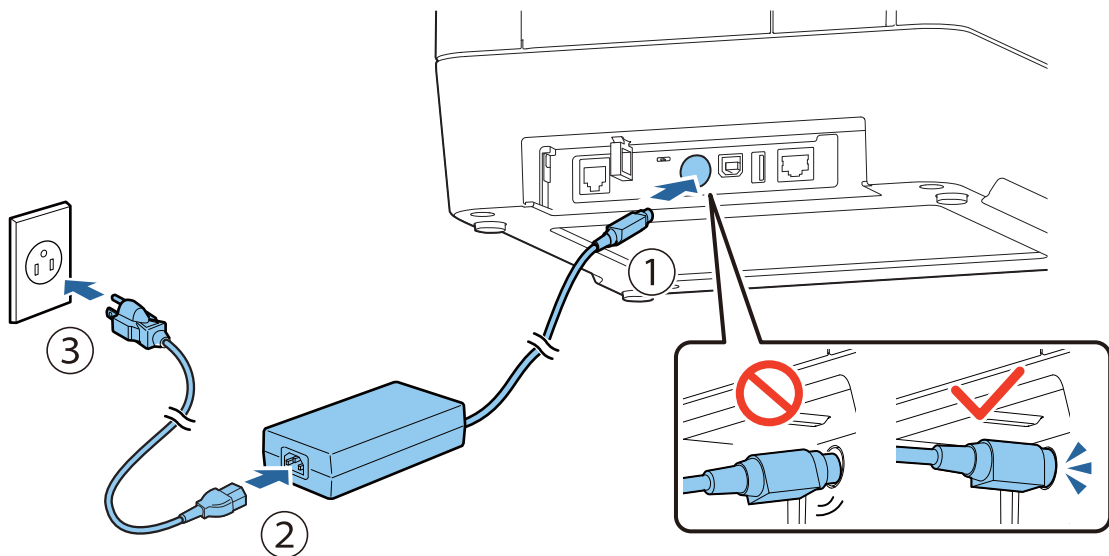

Loading Roll Paper



Take care not to press on the manual cutter with your hand or fingers. Doing so may cause injury.

- 1** Open the roll paper cover. (“Opening the Roll Paper Cover” on page 73)
- 2** Load roll paper, making sure it is oriented correctly.

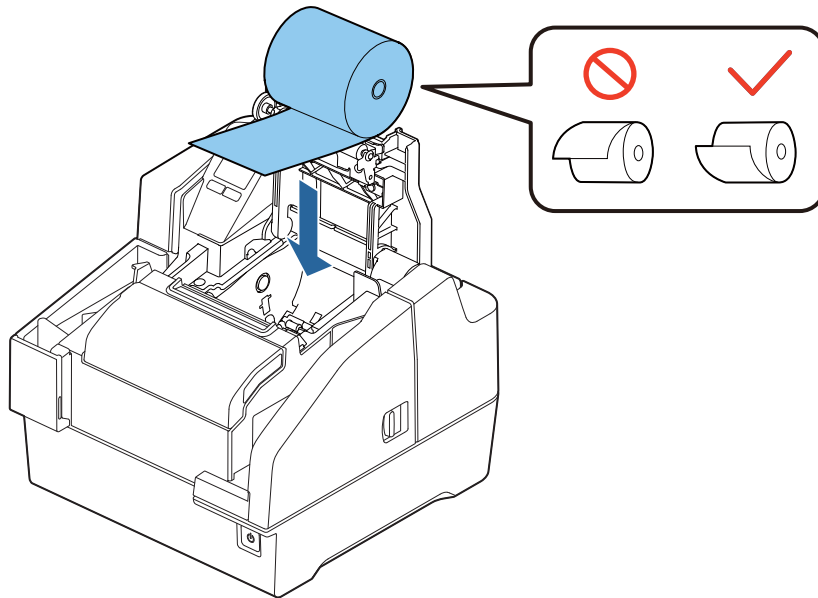

- 3** Pull out the leading edge of the roll paper a little, and close the roll paper cover. If the product is turned on, the roll paper will be cut automatically.

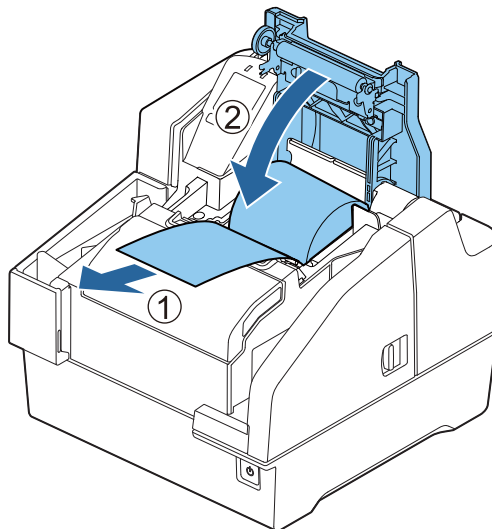

Installing the Ink Cartridges

This section describes the procedure for installing the ink cartridges and performing ink charging for the first time.

When replacing an ink cartridge, refer to “[Replacing the Ink Cartridges](#)” on page 75, and then follow the procedure in this section.



Read the precautions on handling carefully before installing the ink cartridges.
(“[Cautions on Ink Cartridges](#)” on page 9)

- 1 Check that the product is powered on. (“[Turning the Power On](#)” on page 72)
- 2 Open the ink cartridge cover. (“[Opening the Ink Cartridge Cover](#)” on page 73)
- 3 Remove a new ink cartridge from its bag.
- 4 Peel the yellow film from the ink cartridge.

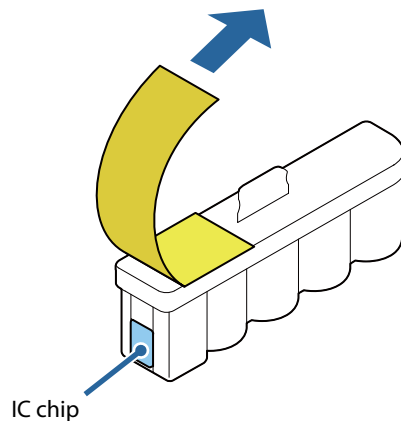

- Do not remove the other label.
- Do not touch the IC chip.

5 Gently press the ink cartridge into the product.

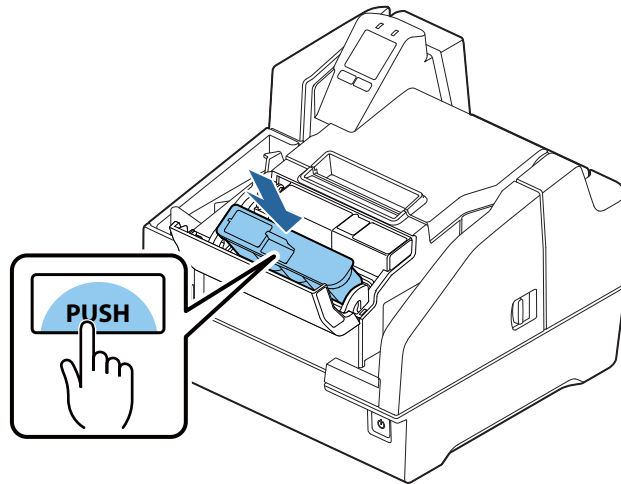

6 Close the ink cartridge cover.

Ink charging starts. The Ⓛ (POWER) LED flashes during ink charging. It takes up to 4 minutes to charge the ink the first time ink cartridges are installed in the product.

When ink charging completes, the Ⓛ (POWER) LED changes from flashing to on.



CAUTION

Never open any cover of the printer or turn off the printer during ink charging (while the Ⓛ (POWER) LED is flashing). Doing so will consume a large amount of ink, which may result in the need to replace the ink cartridges before the completion of charging.

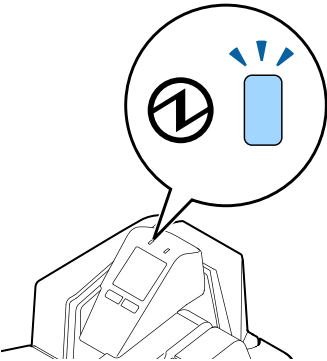



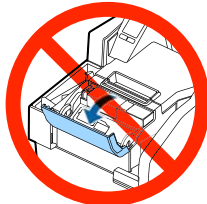

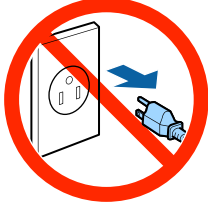

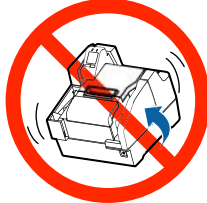

NOTE

The ink cartridges included in the product package are used for initial charging. The product uses ink to prepare for printing (ink charging) when the ink cartridges are installed for the first time.

The installing of ink cartridges is now complete.

Connecting to a Host

Connecting to an Ethernet LAN

- 1 Put the product in network mode using the interface selection switch on the rear.

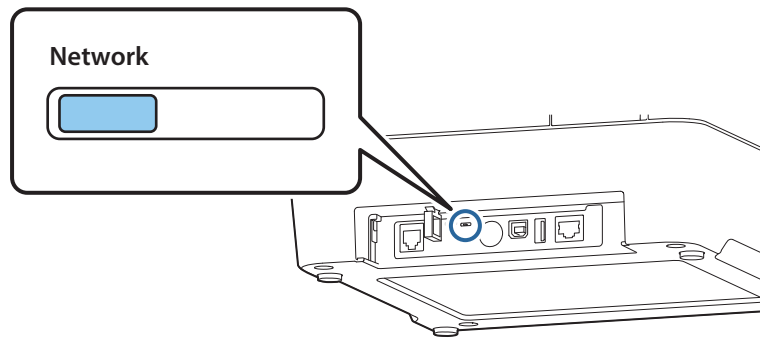

NOTE

The product is in the network mode by default.

- 2 Connect a LAN cable to your router or hub.

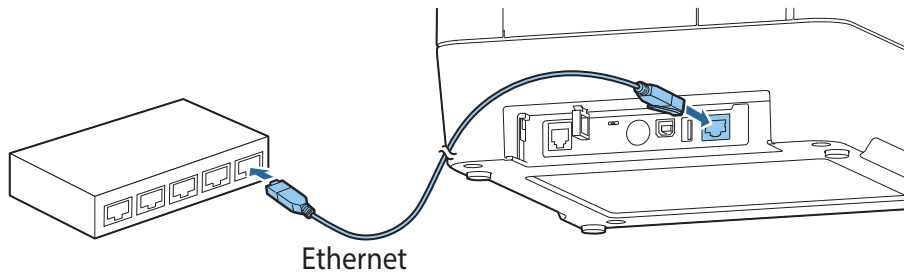

- 3 Turn on the product.
- 4 Press Button 1 and Button 2 at the same time for two seconds to display and check the network settings of the product.
- 5 Start a browser on the host device and enter the IP address of the product to open Web Config.
- 6 Modify the product's network settings in Web Config.
- 7 Restart the product.

Connecting to a Wireless LAN

- 1 Put the product in network mode using the interface selection switch on the rear.

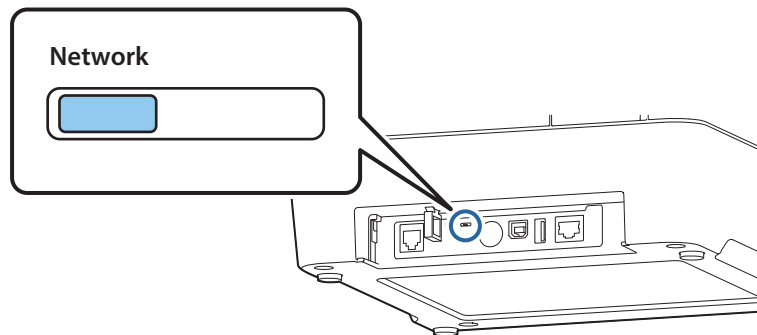

NOTE

The product is in the network mode by default.

- 2 Connect a LAN cable to your router or hub.

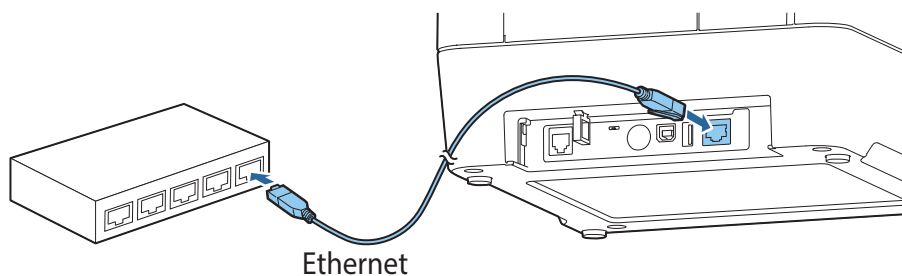

- 3 Connect the optional wireless LAN unit.
- 4 Turn on the product.
- 5 Press Button 1 and Button 2 at the same time for two seconds to display and check the network settings of the product.
- 6 Start a browser on the host device and enter the IP address of the product to open Web Config.
- 7 Modify the product's wireless network settings in Web Config.
- 8 Disconnect the LAN cable.
- 9 Restart the product.

Connecting via USB

- 1 Put the product in USB mode using the interface selection switch on the rear.

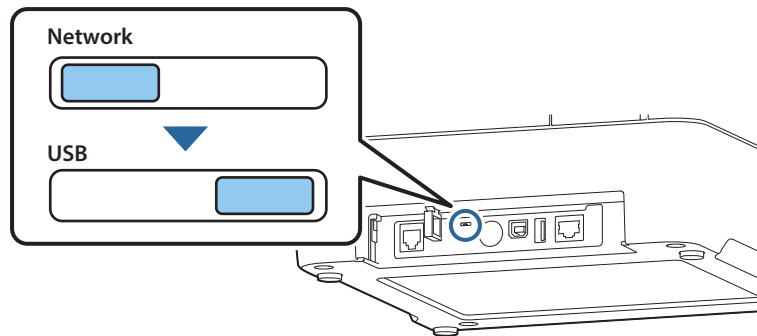

NOTE

The product is in the network mode by default.

- 2 Connect the USB cable that connects to the host computer to the connector on the back of the product. ([“Rear” on page 19](#))

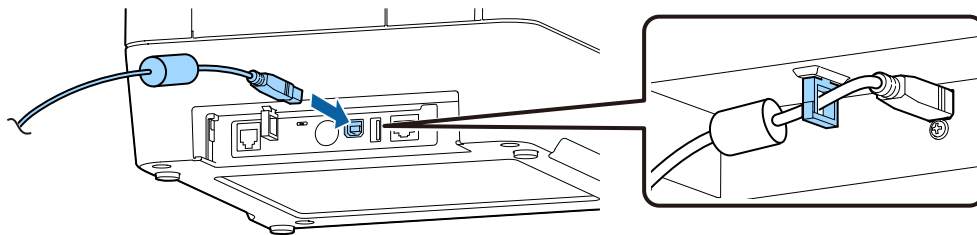

CAUTION

- Pass the USB cable through the wire saddle to prevent accidental disconnection.
- Use of the included USB cable is recommended. Use of another USB cable can result in improper operation during large-volume data processing when scanning a series of documents.

Attaching the Connector Cover

When using the connector cover, attach it as shown in the figure.

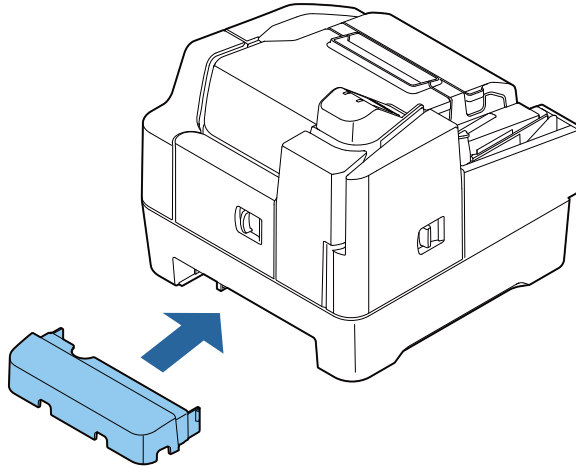

Adjusting LCD Backlight Brightness

Adjust the brightness of the LCD to suit the environment where the product is being used. The changed setting is retained even if the power is turned off. Available brightness settings are bright, normal, and dark.

- 1 Open the ink cartridge cover. ([“Opening the Ink Cartridge Cover” on page 73](#))
- 2 Press Button 1 (dark) to make the display dark, or Button 2 (bright) to make the display bright.

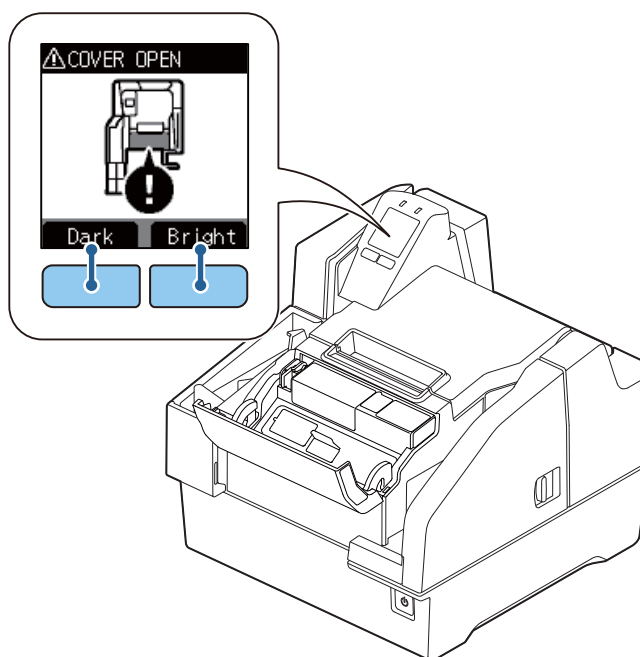

- 3 Close the ink cartridge cover.

Checking the Nozzles by Test Printing on Cut Sheets

Self-test printing can be used to check product settings. Self-test printing on cut sheets can be used to check for missing dots and other printing irregularities.

For printing procedure, refer to [“Self-Test Printing on Cut Sheets”](#) on page 58.

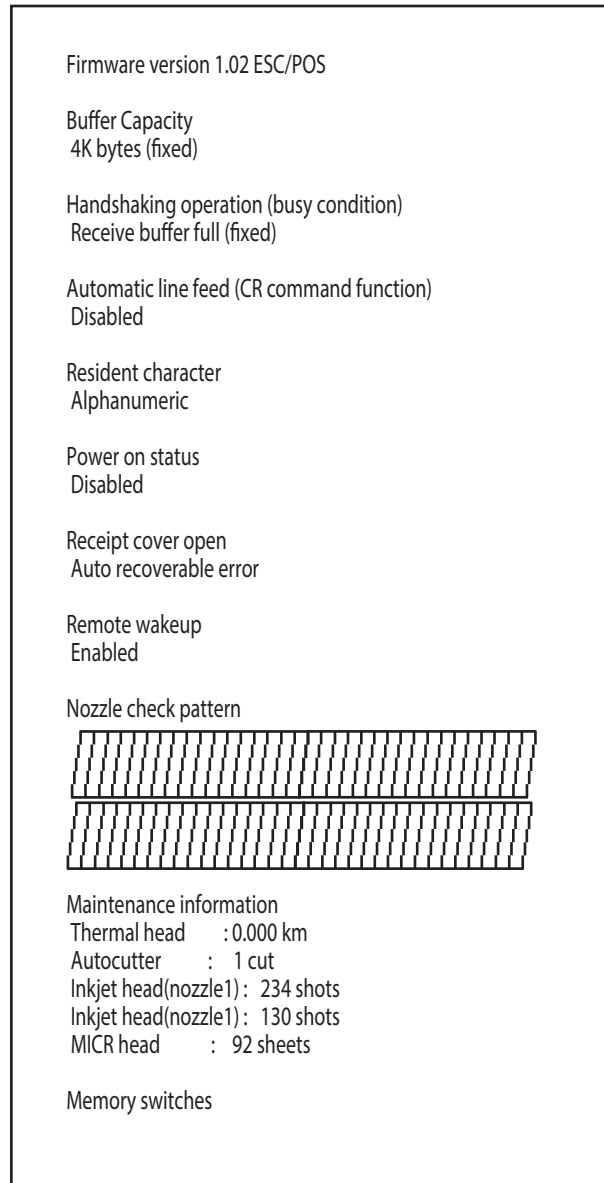

If the test print shows that the nozzle check pattern is blurred, it means that ink head cleaning is required. ([“Ink Head Cleaning”](#) on page 82)

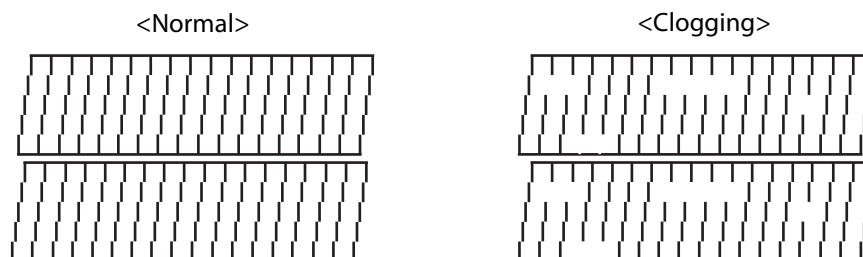

Advanced Product Use

Software Settings

The product has memory switches and customize values as software setting functions, which can be used for configuring various product settings.

The settings can be made by one of the methods described in the table below, by ESC/POS command, or by Web API.

Setting item/setting methods		Software setting mode	TM-S9000II Utility	
Memory switch	Transmits the power ON information	✓	✓	
	Auto line feed	✓	✓	
	Remote wake-up	✓	✓	
	Roll paper cover open during printing	✓	✓	
	Customize value	Roll paper print density	✓	✓
		Paper autocutting after closing the roll paper cover	✓	✓
		Roll Paper Reduction	✓	✓
		Print density when multiple tone printing	✓	✓
		Sets time to check ink head cleaning		✓
		Print Start Position		✓
		Validation settings		✓
		Cut sheet settings		✓
		Time to enter power saving mode		✓
Function to prevent printing on the back side of documents (endorse) without magnetic ink characters			✓	
MICR appearance judgment position using the function to prevent printing on the back side of documents (endorse) without magnetic ink characters		✓		
R/E	Settings for auto Top Logo / Bottom Logo printing		✓	
	Extended settings for auto Top Logo / Bottom Logo printing		✓	

NOTE

- For information on the software setting mode, refer to [“Software Setting Mode” on page 62](#).
- For details on the TM-S9000II Utility, refer to the TM-S9000II Utility User's Manual.
- For more information on the Web API, refer to the TM-S9000II-NW/TM-S2000II-NW Web API Reference Guide.

Function

Transmits the power ON information

- No send (default setting)
- Send

Auto line feed

- Always disabled (default setting)
- Always enabled

Remote wake-up

- Enabled (default setting)
- Disabled

Roll paper cover open during printing

- Automatic recovery error (default setting)
- Recoverable error

Roll paper print density

Selectable level 1 to 13 (70% to 130%)

Default setting: Level 7 (standard)

In order to ensure high print quality, setting the print density is recommended in accordance with the type of paper being used as shown in the table below.

Original paper type	Density
AF50KS-E	4 (85%)
TF50KS-EY, P220AGB-1	5 (90%)
TF60KS-E, PD160R, PD190R, KT48FA, KT55FA, F5041(55), F5041(48)	7 (100%)
P30521, P30523, P31523, P35524	8 (105%)

NOTE

The higher the print density, the lower the printing speed.

Paper autocutting after closing the roll paper cover

- Cut (default setting)
- No cut (not recommended)

Roll Paper Reduction

Reduction of top margin

- Does not reduce (default setting)
- Reduces

Reduction of bottom margin

- Does not reduce (default setting)
- Reduces

Line space reduction rate

- Does not reduce (default setting)
- 25%
- 50%
- 75%

Line feed reduction rate

- Does not reduce (default setting)
- 25%
- 50%
- 75%

Bar code height reduction rate

- Does not reduce (default setting)
- 25%
- 50%
- 75%

Print density when multiple tone printing

Selectable level 1 to 13 (70% to 130%)

Default setting: Level 7

In order to ensure high print quality, setting the print density is recommended in accordance with the type of paper being used.

NOTE

The higher the print density, the lower the printing speed.

Sets time to check ink head cleaning

Time (hh:mm) can be specified

Default setting: 20:00

Print Start Position

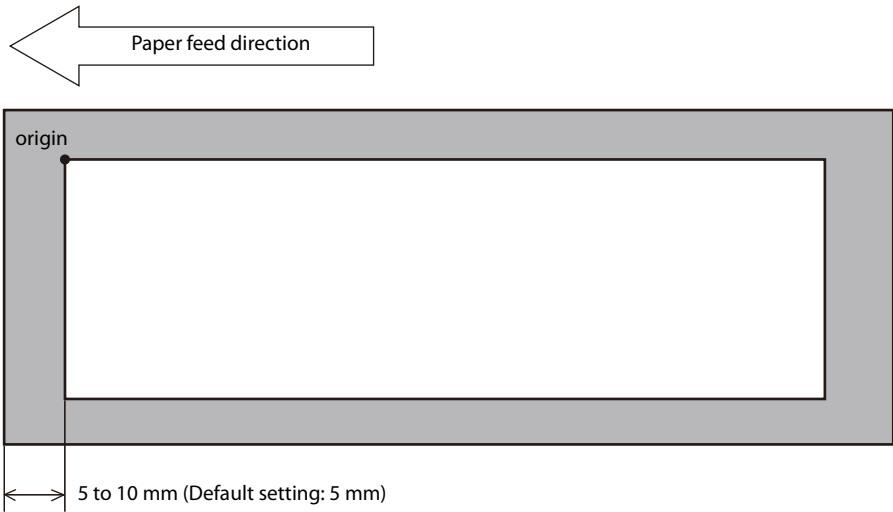

Validation settings

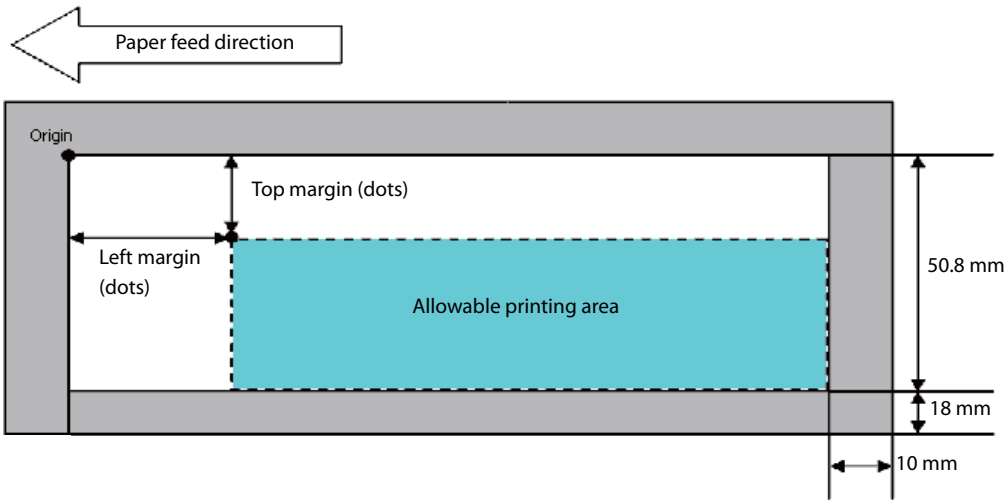

Top margin (default setting: 0) and left margin (default setting: 0) settings are configurable

Cut sheet settings

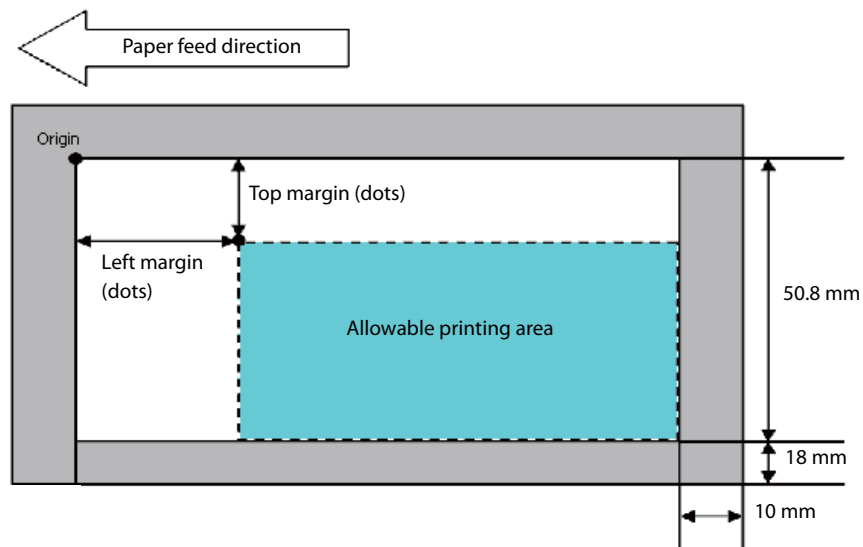

Top margin (default setting: 0) and left margin (default setting: 0) settings are configurable

Time to enter power saving mode

This time can be set within the range of 100 ms [0.1 second] to 3600 s [60 minutes]

Default setting: 300 s [5 minutes]

Function to prevent printing on the back side of documents (endorse) without magnetic ink characters

- Disabled (default setting)
- Enabled

Magnetic ink characters appearance judgment position

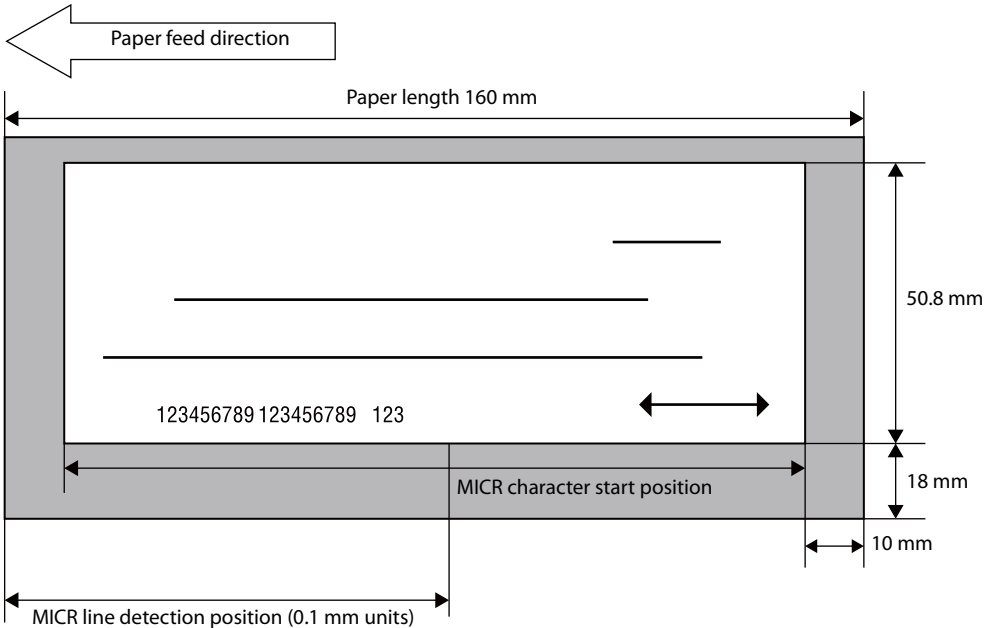

The MICR line judgment location (default: 0) can be specified in 0.1 mm units

Settings for auto Top Logo / Bottom Logo printing

Key codes

You can select from among the key codes of pre-registered logos

Alignment

- Align left
- Align center
- Align right

Extended settings for auto Top Logo / Bottom Logo printing

Top Logo printing when feeding is up to the cut position

- Disabled
- Enabled (default setting)

Top Logo printing when the product is turned on

- Disabled (default setting)
- Enabled

Top Logo printing when covers are closed

- Disabled
- Enabled (default setting)

Setting/Confirmation Mode

In addition to the normal printing modes, the product also includes the modes below for configuring settings and checking the status of functions.

- Self-test mode
- NV graphics information print mode
- R/E information print mode
- Software setting mode

Each mode is selected in accordance with the button that is pressed when the product is turned on and whether a cover is opened or closed.

<Printing on roll paper>

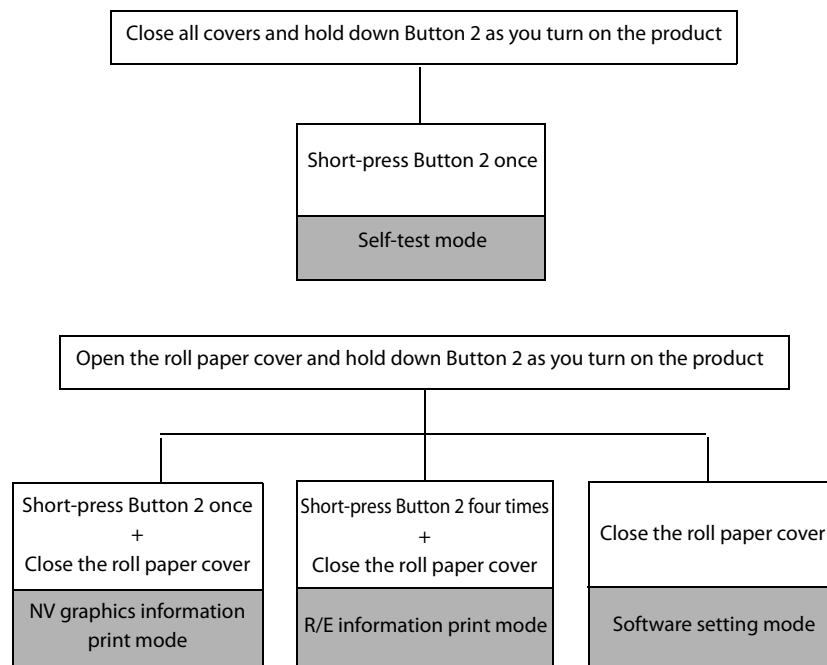

<Printing on cut sheet>

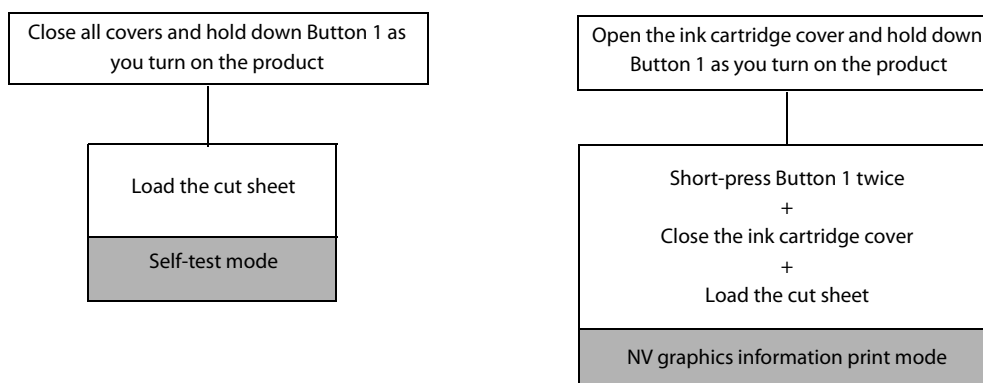

Self-test Mode

You can use the self-test to check the items below.

- Control circuit function
- Printer mechanism function
- Print quality
- Control ROM version
- Memory switch setting function

Perform the procedures below.

Printing to Roll Paper

- 1** Turn off the product and confirm that all covers are closed.
- 2** While holding down Button 2, press the  (POWER) button to turn on the product. This starts test printing on the roll paper.

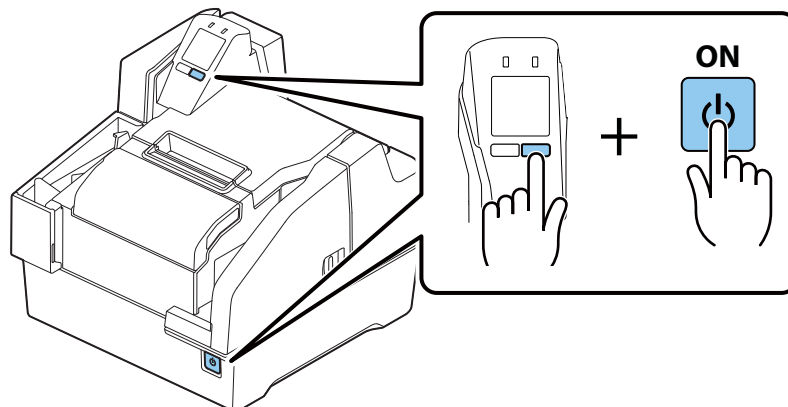

- 3** Press Button 2 (Feed) again. This restarts test printing. Printing is complete when "*** completed ***" is printed.

Self-Test Printing on Cut Sheets

When test printing on cut sheets, use the included cut sheet paper or cut sheets with dimensions of at least 70 mm wide by 152 mm long.

- 1 Turn off the product and confirm that all covers are closed.
- 2 While holding down Button 1, press the  (POWER) button to turn on the product.

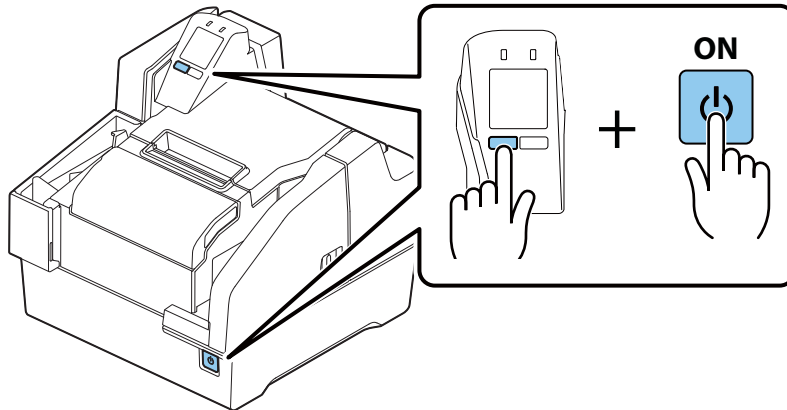

- 3 Load three cut sheets into the ASF. ("[Loading Cut Sheets](#)" on page 77)
Test printing begins. Printing is complete when ***** completed ***** is printed.

NOTE

- Self-test printing uses three cut sheets. The product stands by for insertion of cut sheets until printing is complete.
- If the check doesn't feed correctly, perform the self-test using 3 of the provided new cut sheets. If the printer has not been used for three months or more, please perform this self-test print procedure, and repeat until the unit feeds correctly.

NV Graphics Information Print Mode

This mode prints the NV graphics information below, which is registered on the product.

- NV graphics capacity
- NV graphics capacity usage
- NV graphics remaining free space
- NV number of graphics registrations
- Key code of each data, X-direction dots and Y-direction dots
- NV graphics data

NOTE

For details on NV graphics, refer to “NV Memory” on page 33.

Printing to Roll Paper

- 1 Turn off the product and open the roll paper cover.
- 2 While holding down Button 2, press the  (POWER) button to turn on the product.

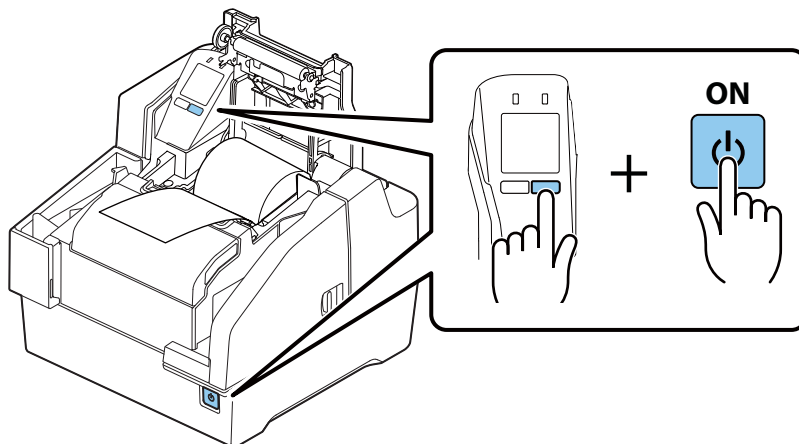

- 3 Press Button 2 twice.
- 4 Close the roll paper cover.
This starts printing of NV graphics information.

NOTE

Initialization starts after printing is complete. Next, the product transitions to its normal state (printing/scanning enabled).

Printing on Cut Sheets

When test printing on cut sheets, use the included cut sheet paper or cut sheets with dimensions of at least 70 mm wide by 152 mm long.

- 1 Turn off the product and open the ink cartridge cover.
- 2 While holding down Button 1, press the  (POWER) button to turn on the product.

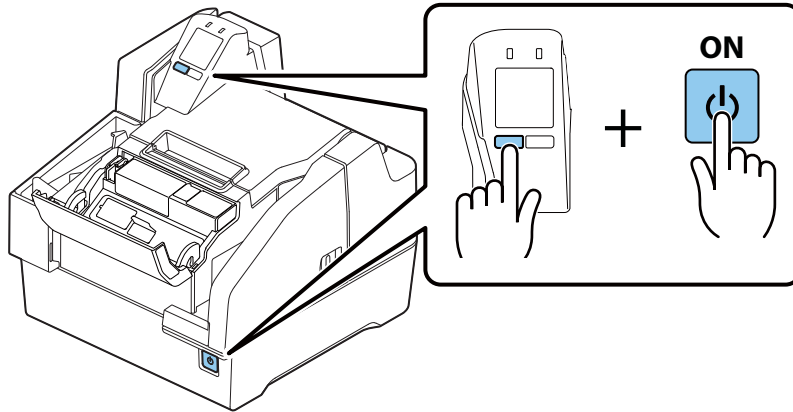

- 3 Press Button 1 twice.
- 4 Close the ink cartridge cover.
This starts printing of NV graphics information.

NOTE

Initialization starts after printing is complete. Next, the product transitions to its normal state (printing/scanning enabled).

R/E Information Print Mode

This mode prints the receipt enhancement information below, which is registered on the product.

- Auto Top Logo setting
- Auto Bottom Logo setting
- Auto Top Logo/auto Bottom Logo extended settings

Perform the procedures below.

- 1** Turn off the product and open the roll paper cover.
- 2** While holding down Button 2, press the  (POWER) button to turn on the product.

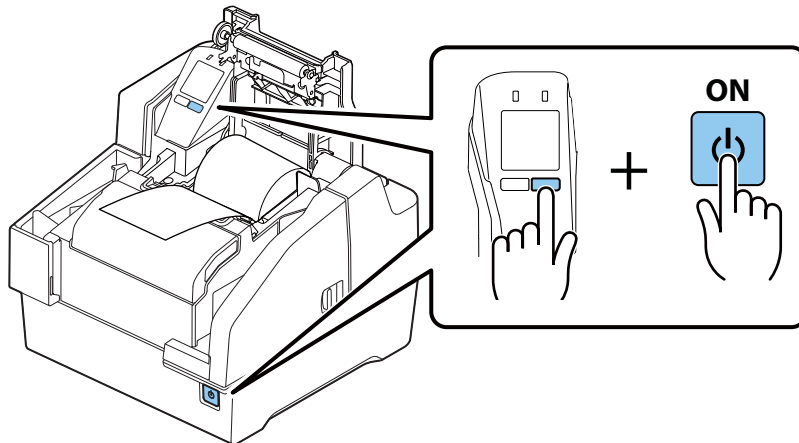

- 3** Press Button 2 four times.
- 4** Close the roll paper cover.
This starts R/E (receipt enhancement) information printing.

NOTE

Initialization starts after printing is complete. Next, the product transitions to its normal state (printing/scanning enabled).

Software Setting Mode

Use this mode to configure settings for the product's memory switches and customize values.

- Roll paper print density
- Auto paper use reduction
- Paper auto cutting after closing the roll paper cover
- Error operation setting
- Transmits the power ON information
- Communication settings

NOTE

For details on memory switches and customize values, refer to [“Software Settings” on page 49](#).

Perform the procedures below.

- 1 Turn off the product and open the roll paper cover.**
- 2 While holding down Button 2, press the  (POWER) button to turn on the product.**

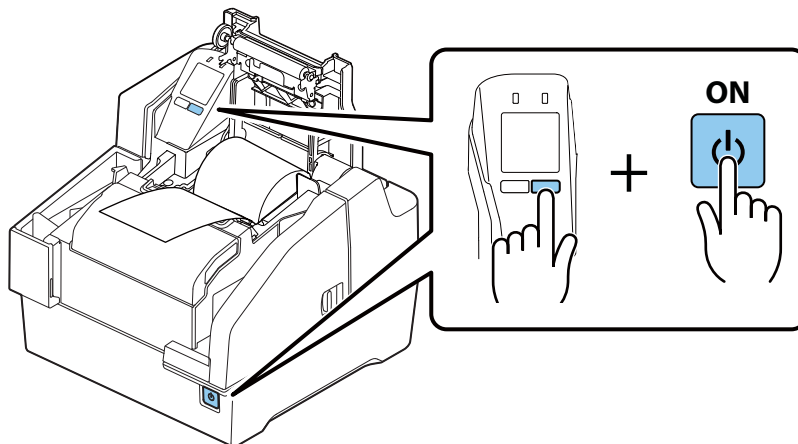

- 3 Close the roll paper cover.**
This prints software setting mode guidance. Follow the instructions that are provided.

NOTE

When you finish configuring settings, they are saved to the product and initialization starts. Next, the product transitions to its normal state (printing/scanning enabled).

Printing a Status Sheet (network mode only)

The following procedure allows you to print a status sheet to check the interface settings.

NOTE

If the power LED is flashing, wait until the LED stops flashing and stays on.

- 1 Remove the connector cover if it is attached.**
- 2 Check that the product is powered on.**
Make sure the roll paper cover is closed.
- 3 Press and hold the status sheet button for at least 3 seconds.**
Printing of the status sheet begins.

NOTE

Only information about the Ethernet and Wi-Fi interfaces are printed.

```

HHH Network Status Sheet HHH

<General Info>
MAC Address      XX:XX:XX:XX:XX:XX
Firmware        XX.XX
                (XXXXXXXXXXXXXX)
Printer Model    TM-S9000II-NW
Device Name     XXXXXXXX

<Ethernet>
Network Status   Auto(Disconnected)
Port Type        Auto

<Wireless>
Wireless         Off
Comm Mode        None
Operation Mode   None
Comm Speed       None
SSID             None
Channel          None
:
:

<TCP/IP IPv4>
IPv4             Enable
Obtain IP Address Auto(APIPA)
IP Address       XXX.XXX.XXX.XXX
Subnet Mask      XXX.XXX.XXX.XXX
Default Gateway  None
APIPA           Enable
:
:

<TCP/IP IPv6>
IPv6            Enable
:
:

```

Initializing Interface Settings

The following procedure allows you to restore the interface settings to their factory defaults.

NOTE

Only the network settings are initialized.

- 1 Make sure the printer is turned off and the roll paper cover is closed.**
- 2 Remove the connector cover if it is attached.**
For information on how to remove the connector cover, see [“Attaching the Connector Cover” on page 46](#).
- 3 While holding down the status sheet button, turn on the product.**
A message saying starting the initialization is printed and the product restarts.

CAUTION

Keep pressing the status sheet button until the initialization start message is printed.

Scanning Demonstration (network mode only)

Enter the IP address of the product followed by /demo in your web browser to launch Scan Demo.

<http://xxx.xxx.xxx.xxx/demo>

The screenshot shows the EPSON Scan Demo web interface. At the top, the EPSON logo is on the left, 'Scan Demo' is in the center, and 'OSS License' is on the right. Below the header, there are two buttons: 'Connect' and 'Disconnect'. Underneath these is a 'MICR' label followed by a large empty rectangular area. At the bottom of the page, there is a navigation bar with '< 1 >' in the center, a checked checkbox labeled 'Read all documents set in the Auto Sheet Feeder', and five buttons: 'Configure', 'Scan Start', 'Cancel', 'Clear', and 'Print'.

Firmware Update

You can update the product firmware by following the steps below.

CAUTION

- The firmware update tool used depends on the connection method.
 - * Network connection: Firmware Updater
 - * USB connection: FlashWriter
- The tool can be obtained from the URL listed in [“Downloading Software” on page 71](#).

- 1 Turn on the product.**
- 2 Update the firmware using the firmware update tool.**
During the firmware update, the power LED flashes and the product restarts.
- 3 Confirm that the tool indicates that the update is complete.**

Application Development Information

This chapter describes product control methods and the information required to develop applications used by the product.

Operating Environment

The operating environment required to get the most out of the product's basic specifications differs depending on the connection method.

When Connected over a Network

- ❑ PC
 - CPU: At least Intel Celeron 3205U 1.5 GHz or the equivalent
 - Memory: At least 1 GB or above the minimum operating system requirement

- ❑ Tablet
 - CPU: Dual-core 1.8 GHz equivalent or higher
 - Memory: At least 512 MB

- ❑ Network environment
 - Wired LAN: 10BASE-T/Full duplex or higher

When connected via USB

- ❑ PC
 - CPU: At least Intel Celeron 3205U 1.5 GHz or the equivalent
 - Memory: At least 1 GB or above the minimum operating system requirement
 - HDD: Free space of more than 30 MB (Before installing the driver)
 - I/F: USB2.0 Hi-speed

Driver for Windows Environment

The drivers described below are available for application development.

For detailed information on functions and support environments, refer to the documentation that comes with each driver.

- EPSON TM-S9000 Driver
Use the API (application interface) to implement product functions. Development can be performed using Visual C++, Basic, and other programming languages.
- EPSON TM-S9000 TWAIN Driver
This driver is for control of products that use TWAIN, which is a standard interface for scanners.
- EPSON Windows Printer Driver for TM-S9000
This is a standard printer driver for Windows.

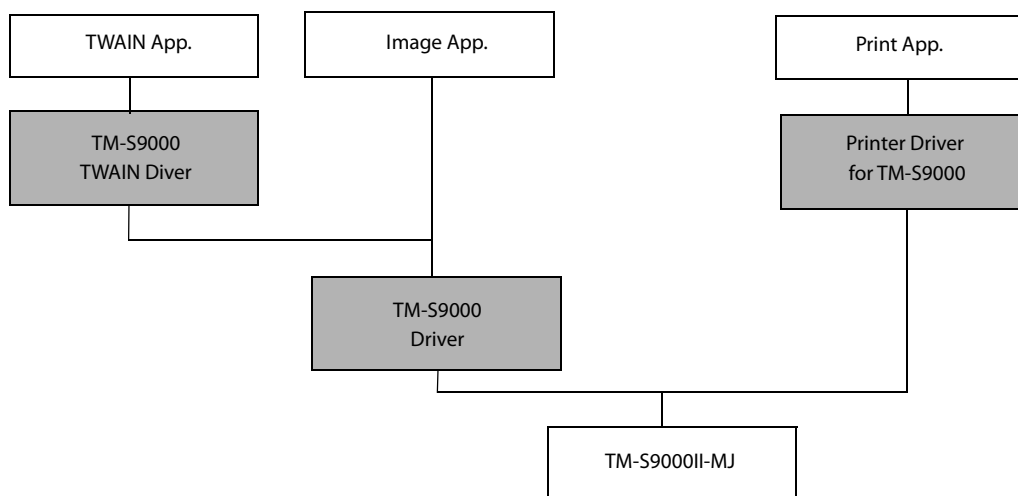

List of Supported Functions

✓: Supported -: Unsupported

	TM-S9000 Driver		TM-S9000 TWAIN Driver		Windows Printer Driver for TM-S9000	
	USB connection	Network connection	USB connection	Network connection	USB connection	Network connection
Scanning cut sheet	✓	-	✓	-	-	-
Reading MICR characters on a check	✓	-	✓	-	-	-
Endorsement printing of a check	✓	-	✓	-	-	-
Electronic endorsement printing	✓	-	✓	-	-	-
Scanning ID Cards	✓	-	✓	-	-	-
Printing on cut sheet (printing receipt on cut sheet or printing on a cashier's check)	✓	-	-	-	✓	✓
Printing on roll paper	✓	-	-	-	✓	✓
MSR*	-	-	-	-	-	-

*: In USB mode, MSR is recognized as the USB HID-Keyboard interface.

Web API

Web API is available for application development.

It has the following functions:

- Scanning a check
- Reading MICR characters on a check
- Endorsement printing of a check
- Electronic endorsement printing
- Scanning ID Cards
- Printing on cut sheets (printing receipt on a cut sheet or printing on a cashier's check)
- Printing on roll paper
- MSR

NOTE

For more information on the Web API, refer to the TM-S9000II-NW/TM-S2000II-NW Web API Reference Guide.

ePOS-Print XML

ePOS-Print is an Epson's unique printing function that uses XML and Web Service.

This function creates request messages in XML format using the application on devices such as computers, smart phones, and tablets, and performs printing to a TM printer on the network using Web Service.

See ePOS-Print XML User's Manual for more details.

Utilities

The utilities described below are available for application development.

For details about functions and support environments, refer to the documentation that comes with each driver.

TM-S9000II Utility

This utility is for checking and modifying each of the product's internal values.

It has the following functions:

- Current settings
- Roll paper reduction
- Printing control
- Operation test
- Storing logos
- Automatic paper cut
- Backup/restore
- MSR settings (only in USB mode)

CAUTION

If you have changed the MSR settings in USB mode and then want to use MSR in Network mode, please initialize the MSR settings. Data cannot be read from MSR properly if not using the initial settings. To perform initialization, use "Default All" in the MagSwipe Configuration Utility. For details, refer to the TM-S9000II Utility User's Manual.

Epson Deployment Tool

This tool can be used to change product settings and printer driver settings. The settings of multiple products can be configured simultaneously, which reduces work time.

BmpToRaster

This is a utility for converting Windows BMP files to ESC/POS command raster graphic data.

It has the following functions:

- TM-S9000II-MJ multi-tone image print data creation
- Monochrome image print data creation
- Binary file graphic printing

Downloading Software

Download the latest version of each software from the URLs below.

For customers in North America, go to the following web site:
<https://www.epson.com/support/>

For customers in other countries and regions, go to the following web site:
<https://epson.sn>



Handling the Product

This chapter describes the basic handling procedures for the product.

Turning On/Off



This section describes how to turn the product on/off.

Turning the Power On

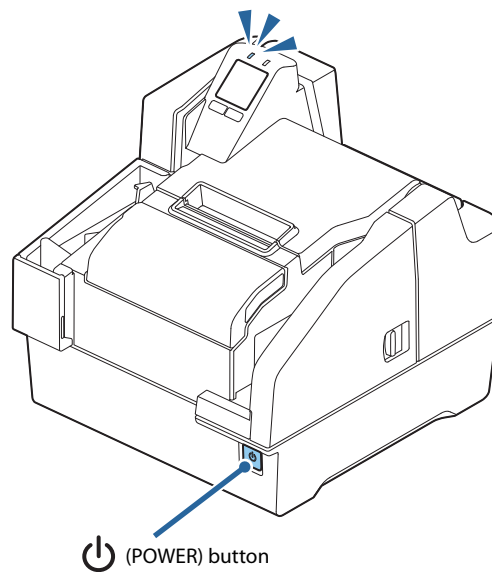
Hold down the  (POWER) button for at least 1 second until the  (POWER) LED turns on.



Turning the Power Off

Hold down the  (POWER) button for at least 3 second until the  (POWER) LED turns off.

To turn off power without using the  (POWER) button, send the command that executes the power off sequence.



- Do not remove and insert the power plug from/to the outlet while the power of the product is in the on state. Doing so may cause electric shock or fire.
- Turning off the product by performing a  (POWER) button operation or by sending a command causes the ink head to be capped automatically to prevent the ink from drying. If you do not plan to use the product after installing an ink cartridge, be sure to use either of the methods above to turn off power. Do not pull out the power plug or turn off the breaker while the power is on.

Opening a Cover

This section describes how to open each of the product's covers.

Opening the Ink Cartridge Cover

Use your finger to lift up the tab on the left side of the ink cartridge cover, and open the cover toward you.

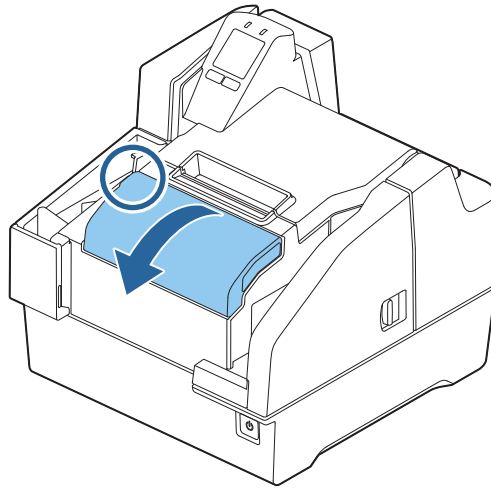

Opening the Roll Paper Cover

Use your finger to lift up the tab on the left side of the roll paper cover, and raise the cover to open it.

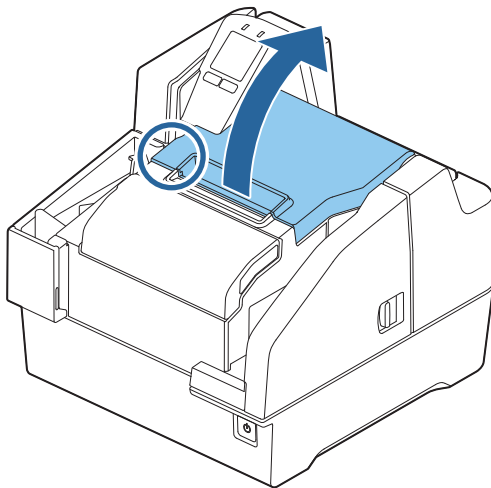

Opening the MICR Cover, Back Cover, and Scanner Cover

Pull the cover lever and then swing the cover outwards to open it.

<MICR cover>

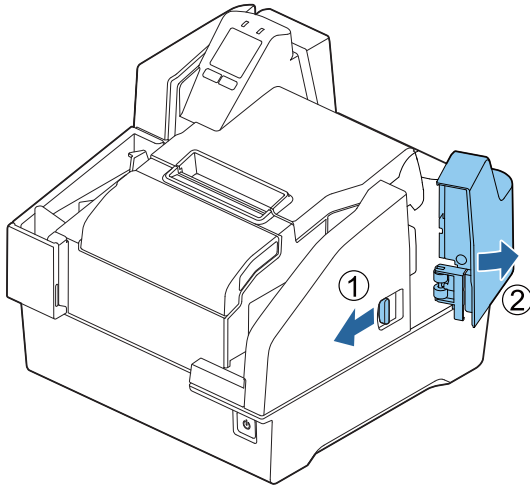

<Back cover>

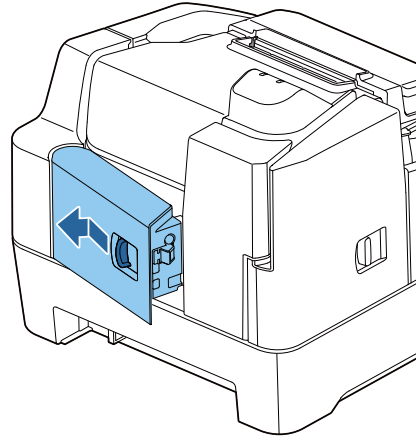

<Scanner cover>

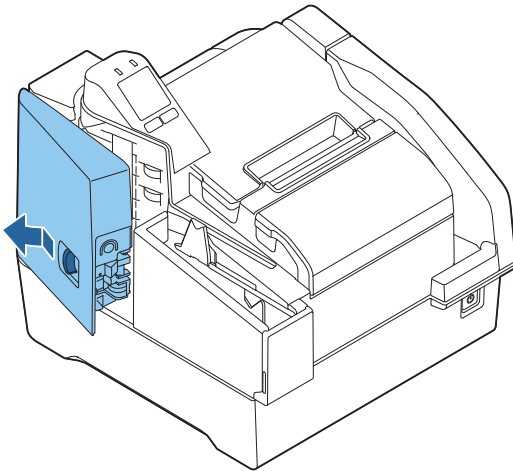

Replacing the Ink Cartridges

If the LCD displays the animation shown below, it is time to replace the ink cartridge.

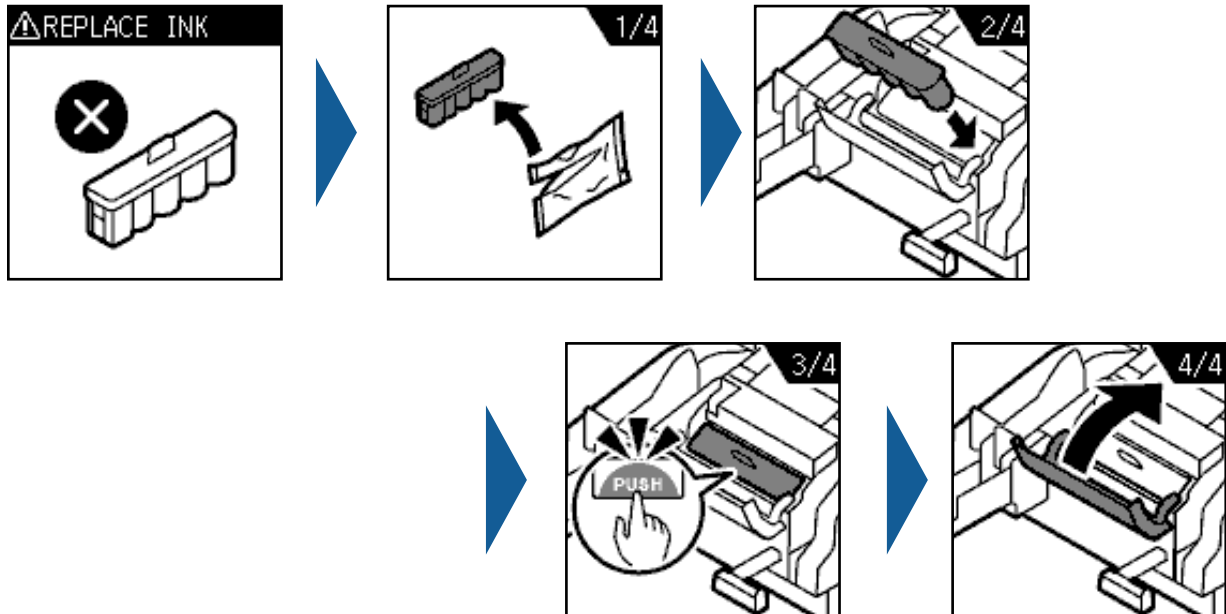

For the replacement procedure, refer to [“Installing the Ink Cartridges” on page 41](#). Replacement can be performed with the same procedure. Grasping the tab on the top side of the used ink cartridge, pull it out to remove it.

For the model numbers of the ink cartridges, refer to [“Ink Cartridge” on page 97](#).

Replacing Roll Paper

If the LCD displays the animation shown below, it is time to replace the roll paper.

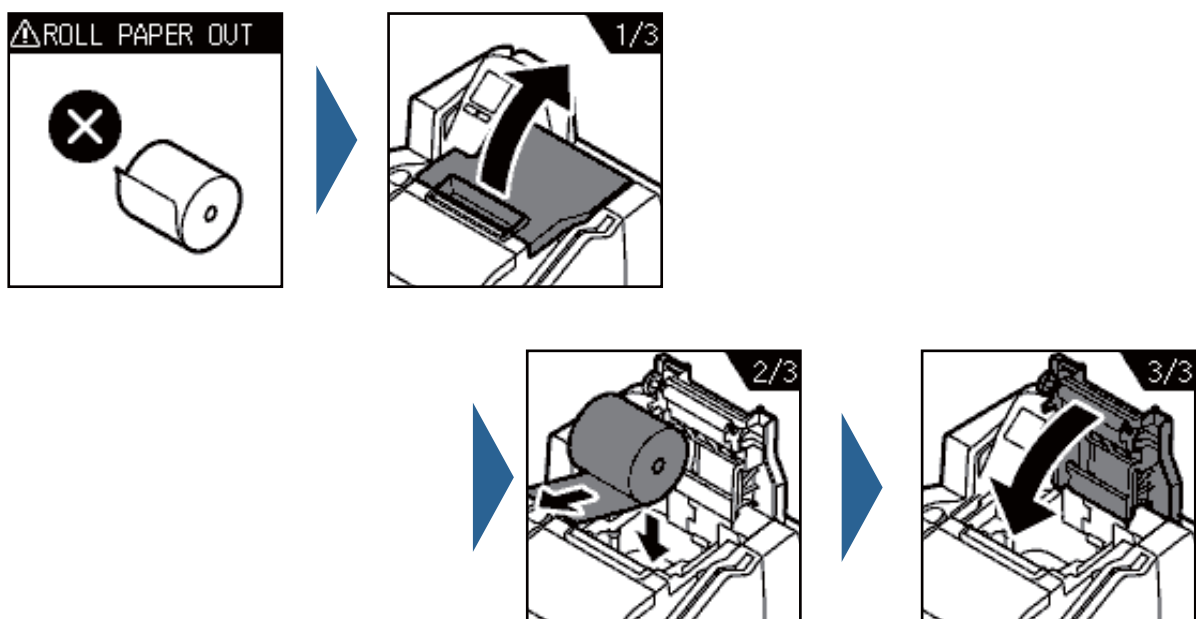

For information on roll paper replacement, refer to [“Loading Roll Paper” on page 40](#). Replacement can be performed with the same procedure. Do not leave the core of used roll paper in the product.

Cut Sheet Processing

This section describes cut sheet processing.

Process Flow

The processing flow below is performed by the product, from the point cut sheets are loaded in the ASF until they are ejected to a pocket.

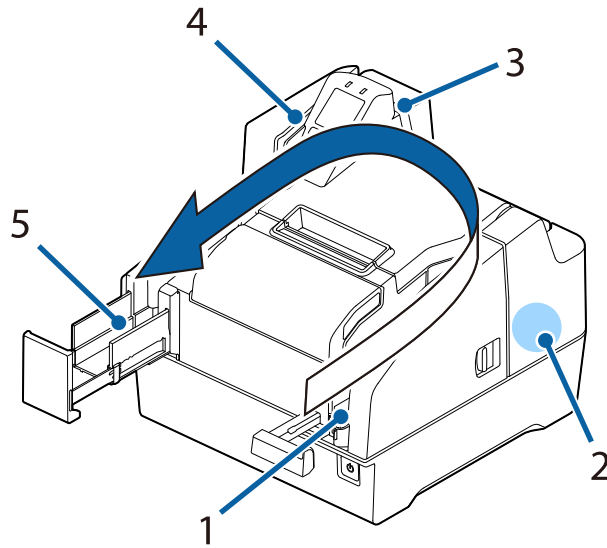

1	Cut sheet feed Inserted cut sheets are separated one-by-one and fed.
2	MICR reading Reads the magnetic ink characters printed on checks.
3	Print Prints on cut sheets.
4	Scanning Reads both sides of cut sheets.
5	Eject/store Processed cut sheets are ejected and stored.

Loading Cut Sheets

Use the procedure below to load cut sheets.

Up to 100 cut sheets can be loaded in the ASF.

- 1 Pull out the ASF guide and pocket guide to match the length of the paper.

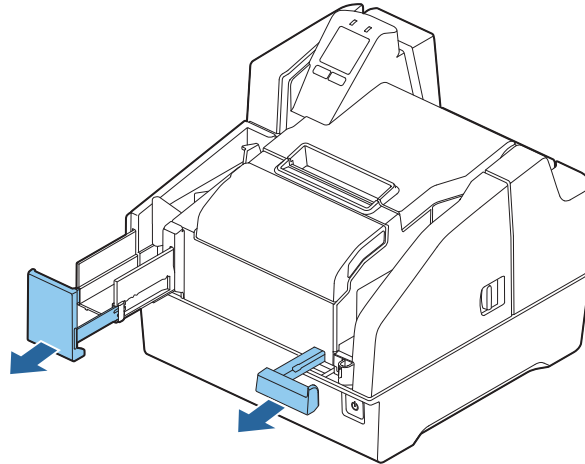

- 2 Load the cut sheets so they are aligned with the ▲ mark on the right side of the roll paper cover.

When reading MICR characters, load the sheets so the magnetic ink characters are facing away from and toward the bottom of the product. When loading multiple sheets, first align them on their lower right corners.

When loading multiple sheets of different sizes, also align them on their lower right corners.

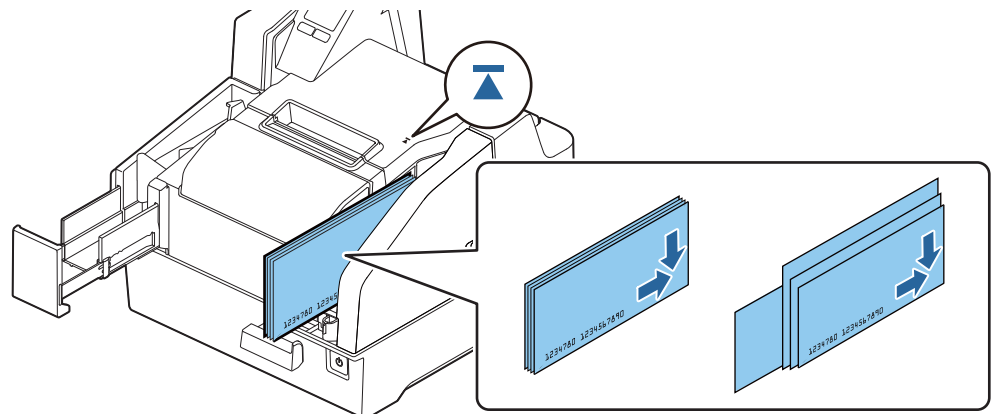

CAUTION

Note the precautions below. Failure to satisfy these conditions can result in cut sheet reading not starting or cause jamming.

- Use cut sheets that conform to product specifications
- Make sure there are no clips on or staples in the cut sheets, and make sure that the cut sheets are not curled, bent or wrinkled

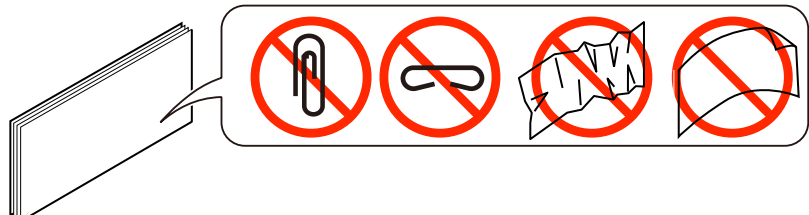

3 Load the paper and remove your hand.



CAUTION

After paper ejection is complete, remove it by hand. Touching the paper or opening the cover while processing is in progress creates the risk of paper jams or unexpected injury.

Removing Cut Sheets

After cut sheets are ejected into the pocket, remove them.

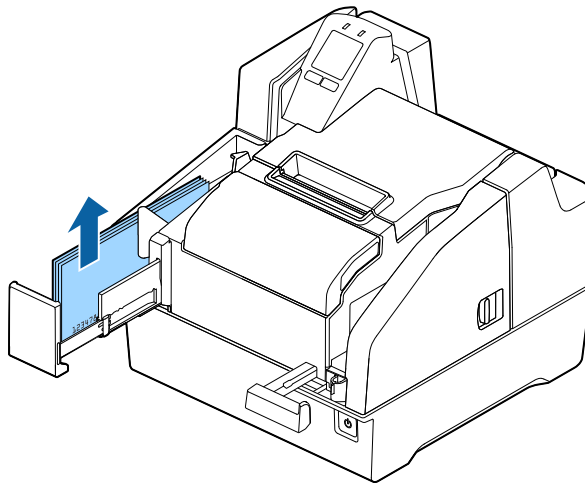

CAUTION

- The pocket can store up to 100 cut sheets. Remove the cut sheets when there are more than 100 sheets, as paper jams may occur.
- Paper feed speed is lower in the case of 300 dpi color image acquisition or simultaneous acquisition of a color image and IR image. Depending on the paper type and conditions, cut sheets may curl in the pocket at this time. Because of this, it is recommended that cut sheets be removed after about 25 sheets are accumulated in the pocket.

ID Card Processing

This section describes ID card processing.

CAUTION

Note the precautions below. Failure to do so can cause ID card reading problems.

- Use ID cards in accordance with specifications.
- Check to make sure that ID cards are not bent, broken, or excessively embossed.
- Do not touch the IC chip of the ID card.
- Do not open a cover, touch the ID card, or block the slot while the product is processing an ID card.

1 Insert the ID card into the slot and slide it.

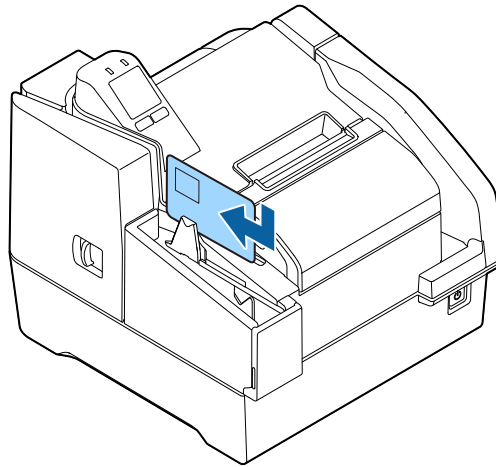

2 Release the ID card after it starts to be fed automatically.

3 After the ID card is ejected, remove it.

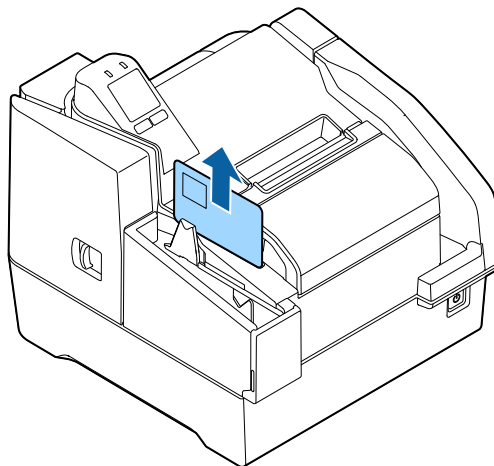

Magnetic Stripe Card Processing

This section describes magnetic stripe card processing.

NOTE

Some models are not equipped with a magnetic stripe card reader (MSR).

CAUTION

Use magnetic stripe cards that conform to product specifications.

Insert the card into the slot so its magnetic stripe is facing toward the product and downward, and then slide downward or upward in the slot. At this time, press down on the card to make sure it is sliding along the bottom of the card slot.

The buzzer sounds once if reading is successful, and three times if it fails.

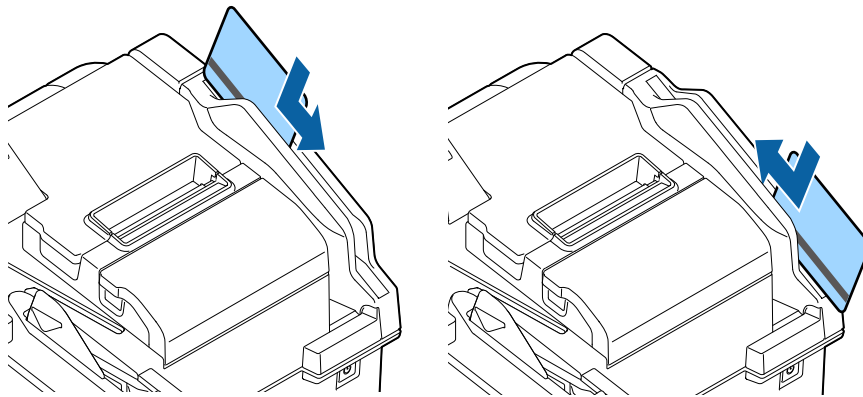

Cleaning the Product

Cleaning the Exterior

After turning off the product, use a slightly damp cloth to wipe it off. Before doing so, be sure to unplug the AC cable from the power outlet.



Do not use alcohol, benzene, thinner, trichloroethylene, or ketone based solvent to clean the exterior of the printer. Doing so may deform or damage the plastic and rubber parts.

Cleaning the Thermal Head and Platen Roller

Epson recommends cleaning the thermal head to maintain receipt print quality. We recommend cleaning periodically (about once every 3 months). To clean the thermal head, use a cotton swab moistened with an alcohol solvent (ethanol or isopropyl alcohol).

Depending on the roll paper used, paper dust may stick to the platen roller and the paper may not be fed correctly. To remove the paper dust, clean the platen roller with a cotton swab moistened with water. Turn on the product power only after the water has completely dried.



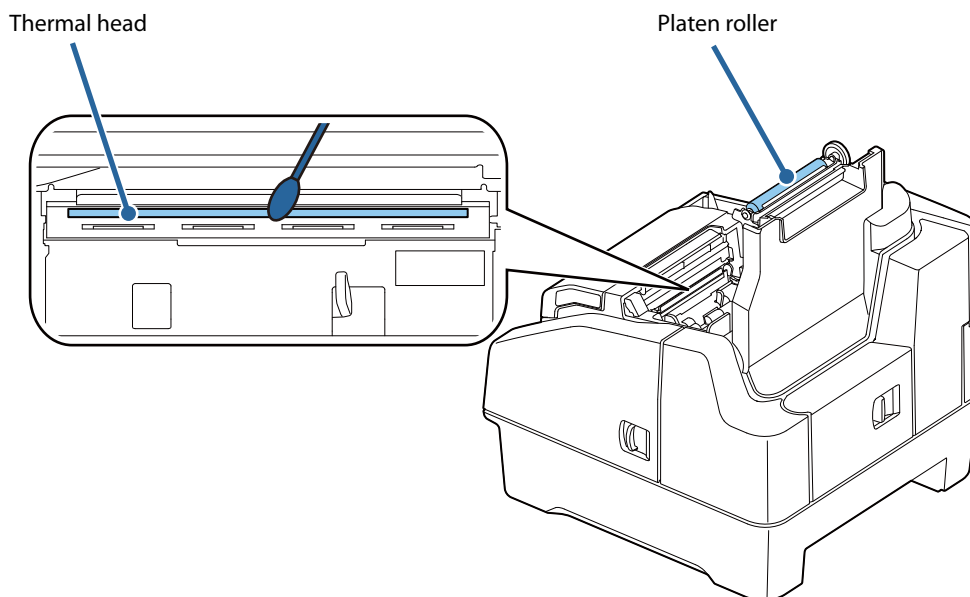

- The thermal head may be very hot after printing. Do not touch the thermal head or components around it for cleaning immediately after printing. Wait for some time to allow the thermal print head to cool down before cleaning it.
- Take care to avoid scratching the thermal print head with your fingers or hard objects.



Ink Head Cleaning

If printing becomes blurred or uneven, even though there is sufficient ink remaining, it means that the ink head needs cleaning.

On the LCD home screen, press the Cleaning button (Button 1). This will display a confirmation message. Press the Yes button (Button 2) to perform the cleaning operation. This starts cleaning and causes the  (POWER) LED to flash. The  (POWER) LED stops flashing when cleaning is complete.



Do not turn off the product or open a cover while cleaning is in progress ( (Power) LED flashing).

CAUTION

- Do not run the head cleaning more than necessary. Ink is consumed because ink is discharged from the head to clean it.
- If there is not enough ink remaining, head cleaning may not be possible. Replace the ink cartridges and then try again.

Cleaning the Paper Feeding Path

If there are problems correctly reading the magnetic ink characters of a check, cleaning of the paper feeding path using a commercially available cleaning kit is required. Periodic cleaning is recommended. The cleaning period is once a week or every 2,000 checks.

Use either of the methods below to perform cleaning.

- Cleaning using the application ([“Cleaning Using the Application” on page 82](#))
- Cleaning using the printer ([“Cleaning Using the Printer” on page 83](#))

Cleaning kit model numbers

KIC Team, Inc.

- Waffletechnology® MICR cleaning card (model:CS1B15WS)
- Epson Check Scanner Cleaning Kit (model:KWEPS-KCS2)

Cleaning Using the Application

Turn on the product and insert a cleaning sheet into the ASF. Use the application to execute a paper feed, which passes the cleaning sheet along the paper path and cleans it.

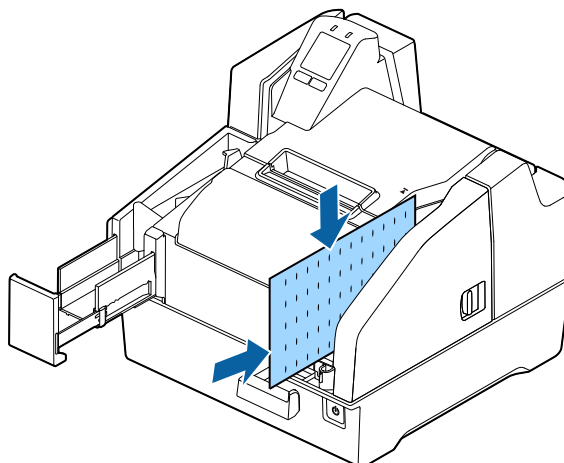

Cleaning Using the Printer

Use the procedure below to perform cleaning.

- 1 Turn off the product and open the ink cartridge cover.
- 2 While holding down Button 1, press the  (POWER) button to turn on the product.

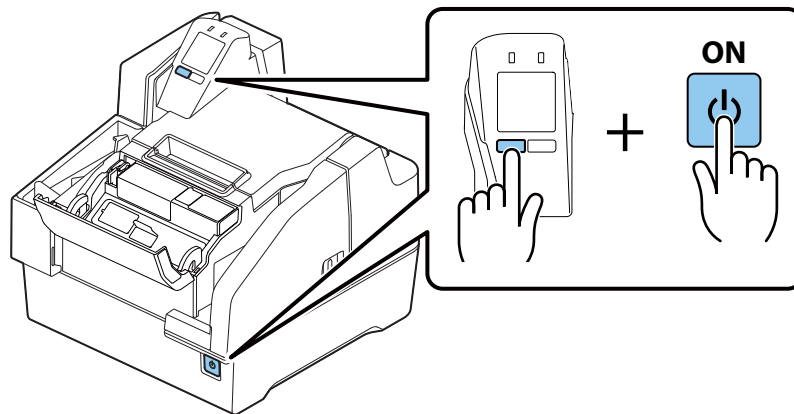

- 3 Press Button 1 three times.
- 4 Close the ink cartridge cover.
- 5 Insert a cleaning sheet into the ASF.

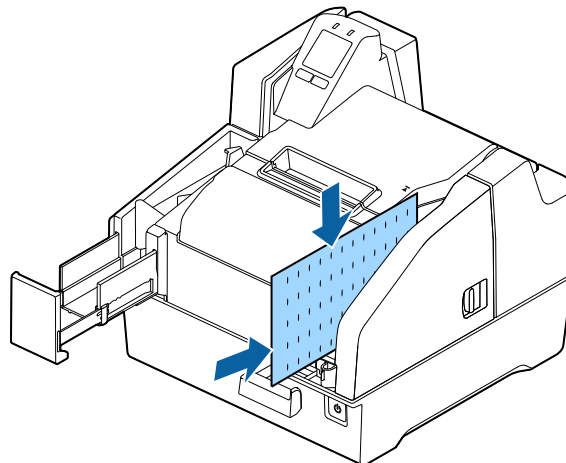

Feed the cleaning card to clean the paper path.

Cleaning the Scanner

If the quality of data read from cut sheets or ID cards is poor, scanner cleaning is required. Periodic cleaning is recommended. The cleaning period is once a week or every 2,000 checks.

Turn off the product and open the scanner cover. Gently wipe the glass using a soft, dry cloth.

CAUTION

- Do not use detergent, water, or other liquid for cleaning. Doing so creates the risk of dirt adhering to the glass.
- If oil, grease, or other similar matter gets on the scanner glass, wipe it with a cloth moistened with alcohol. However, make sure that liquid does not come into direct contact with the scanner glass.

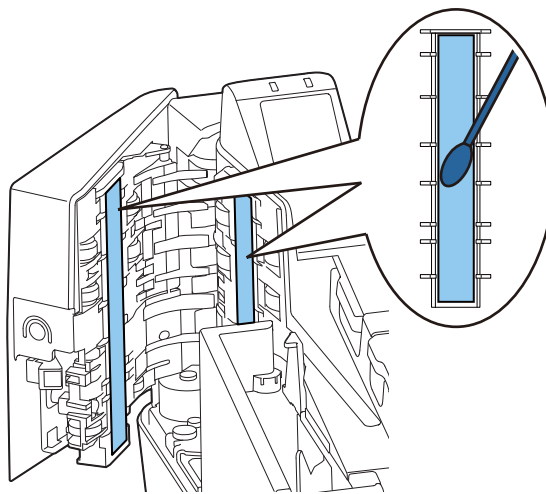

Preparing for Transport

Perform the steps below to prepare the product for transport.

CAUTION

Do not transport a used ink cartridge. Doing so may cause the ink to leak.

- 1** Turn off the power. ([“Turning the Power Off” on page 72](#))
- 2** Confirm that the  (POWER) LED is unlit.
- 3** Disconnect the DC connector from the product.
- 4** Remove the roll paper.
- 5** Remove the ink cartridge.

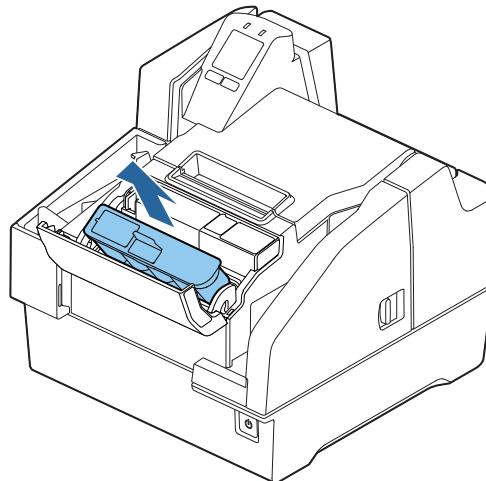

- 6** Store the ASF guide and pocket guide.
- 7** Pack the product so it is supported both from above and below.

Troubleshooting

This chapter describes how to resolve problems.

Trouble	Reference
The Product Does Not Turn On	page 87
Lit or Flashing ! (ERROR) LED	page 87
Error Message Displayed on the LCD	page 87
Cut Sheet Jam	page 91
ID Card Does Not Come Out	page 92
Roll Paper Jam	page 93
Cannot Open the Roll Paper Cover	page 94
Problems with Print Quality	page 95
Problems with Reading Quality	page 95

The Product Does Not Turn On

Making sure each connector is oriented correctly, insert the power cable into the product and the power outlet as far as it will go. ([“Connecting a Power Supply” on page 39](#))

Lit or Flashing ! (ERROR) LED

If the ! (ERROR) LED is lit or flashing, check the message on the LCD for information on resolving the problem. ([“Error Message Displayed on the LCD” on page 87](#))



Error Message Displayed on the LCD

If a message appears on the LCD of the operation panel, try the solution described below.

There are three error types: automatic recovery error, recoverable error, and unrecoverable error.







Automatic Recovery Error

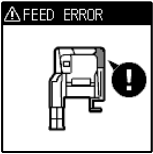

Printing on roll paper is not possible when an automatic recovery error occurs. Take the actions shown in the table below to return the product to its normal state.

LCD display	Error name	Error details	Solution
	Roll paper cover open during printing error * When automatic recovery is selected by using the memory switch (“Roll paper cover open during printing” on page 50)	The roll paper cover is open.	Close the roll paper cover.
	Thermal head high temperature error	The thermal head temperature exceeds that of the drive conditions.	Stop roll paper printing for a while.

Recoverable Error

Product operation stops when a recoverable error occurs. After removing the cause of the error, you can return back to normal by turning power off and then back on again, or by using the error recovery command.

LCD display	Error name	Error details	Solution
	Roll paper cover open during printing error *When recoverable is selected by using the memory switch (“Roll paper cover open during printing” on page 50)	The roll paper cover is open.	With the roll paper cover closed, execute the error recovery command (DLE ENQ (n=2)) or turn power back on.
 	Mechanism position error	The home position of the hopper or the pocket switching board cannot be detected.	Execute the error recovery command (DLE ENQ (n=2)) or turn power back on.
  	Cut sheet jam error	Even if cut sheets are sent a fixed amount, they are not ejected. This could be due to the reasons below. <ul style="list-style-type: none"> Paper feed from the ASF failed Cut sheet jamming was detected Too short or too long cut sheet was detected 	<ul style="list-style-type: none"> If paper feed from the ASF failed: Load the cut sheets so that they are aligned with the  mark on the right side of the roll paper cover. (“Loading Cut Sheets” on page 77) If a cut sheet jam was detected: Remove the jammed paper and then re-load it into the ASF. (“Cut Sheet Jam” on page 91) If a too short or too long cut sheet was detected: Use cut sheets in accordance with the specifications. (“Cut Sheet” on page 109)

LCD display	Error name	Error details	Solution
	Cut sheet feed error	<p>Double-feed of cut sheets. This could be due to the reasons below.</p> <ul style="list-style-type: none"> • Cut sheets were inserted upside down or backwards • Confirmation mode is configured so this condition causes an error • Generation of noise by MICR was detected • Specified print data is longer than the cut sheet length 	<ul style="list-style-type: none"> • If cut sheets were inserted upside down or backwards: Orient cut sheets correctly when loading them. ("Loading Cut Sheets" on page 77) • When the confirmation mode is configured so this condition causes an error: Follow the instructions provided by the application. • When generation of noise by the MICR was detected: Scan again. • When the specified print data is longer than the cut sheet length: Specify print data that is shorter than the length of the cut sheets.
	Auto-cutter error	The auto cutter home position cannot be detected.	Remove the jammed roll paper or the foreign matter from inside the roll paper cover. With the roll paper cover closed, turn the product back on.
	Cartridge recognition error	Ink information writing is not be performed correctly.	<p>Check if the ink cartridge is installed correctly. ("Installing the Ink Cartridges" on page 41)</p> <p>Or you should replace the ink cartridge with a new one. ("Replacing the Ink Cartridges" on page 75)</p>

Unrecoverable Error

When an unrecoverable error occurs, an error code appears on the LCD and product operation stops. If turning the product off and then back on again does not clear the error, servicing is required.



Error code	Error name	Error details
APA11	CPU execution error	CPU is executing an illegal address.
AHB12 AHB11	Read/Write error	Normal operation is not performed following read/write check.
AKA41	High-voltage error	Power supply voltage is high.
AKA42	Low-voltage error	Power supply voltage is low.
AKA11 AAA21 AAF21 AAF31 AKA82 AKA31 AKA71	Drive circuit error	Drive circuit error occurred.
AGB11 AGA14 AGC22 AGD21 AGD22	IJ mechanism error	Ink jet mechanism error occurred.
AKA51	Communication device error	USB error occurred.
AKA81	Double-feed detector noise level error	Noise was detected by the double-feed detector.
AKA83	Double-feed detector detection error	Double-feed detector error occurred.
BGA1F BGA31	Maintenance error	The specified number of pump drives, or the specified absorber absorption volume has been exceeded.
APJ21	Network main board error	There is an error in the network main board.
AKB54	Network interface board error	There is an error in the network interface board.
API23	Firmware version mismatch error	The firmware versions of the printer, network main board, and network interface board do not match. If the firmware is rewritten again and it finishes successfully, the product will recover from the error.

Cut Sheet Jam

Open the applicable cover and remove the jammed cut sheets. The location of the cut sheet jam can be determined by checking the LCD.

CAUTION

Do not pull out cut sheets with excessive force. Doing so can damage the cut sheets and creates the risk of product malfunction.

LCD display	Error details	Solution
	Cut sheets are jammed in the MICR reader.	Open the MICR cover and remove the jammed cut sheets. (“Opening the MICR Cover, Back Cover, and Scanner Cover” on page 74)
	Cut sheets are jammed in the back of the product.	Open the back cover and remove the jammed cut sheets. (“Opening the MICR Cover, Back Cover, and Scanner Cover” on page 74)
	Cut sheets are jammed in the scanner.	Open the scanner cover and remove the jammed cut sheets. (“Opening the MICR Cover, Back Cover, and Scanner Cover” on page 74)

ID Card Does Not Come Out

Open the scanner cover and remove the ID card.

CAUTION	Do not pull out ID cards with excessive force. Doing so can damage the ID card and creates the risk of product malfunction.
----------------	---

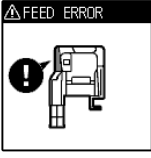
LCD display	Error details	Solution
	An ID card is jammed in the scanner.	Open the scanner cover and remove the jammed ID card. (“Opening the MICR Cover, Back Cover, and Scanner Cover” on page 74)

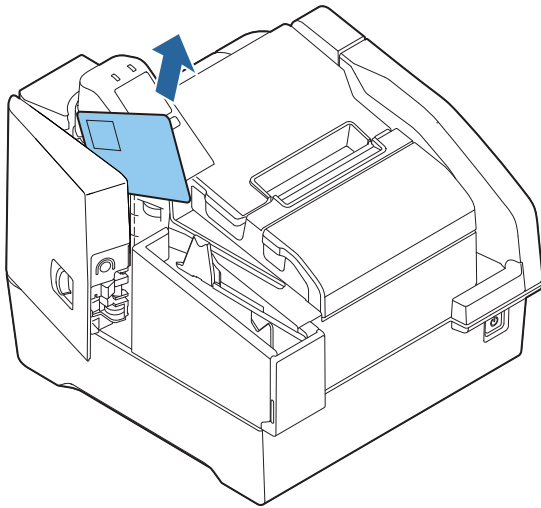

Roll Paper Jam

If roll paper jams, cut off the section of paper wrinkled by the jamming, and then reload the roll paper.



Do not touch the thermal head or the area around it. They may be very hot immediately after a print operation.

CAUTION

Do not pull out roll paper with excessive force. Doing so can damage the roll paper and creates the risk of product malfunction.

- 1** Turn off the product.
- 2** Open the roll paper cover.
- 3** Cut off the section of paper wrinkled by the jamming, and then reload the roll paper.

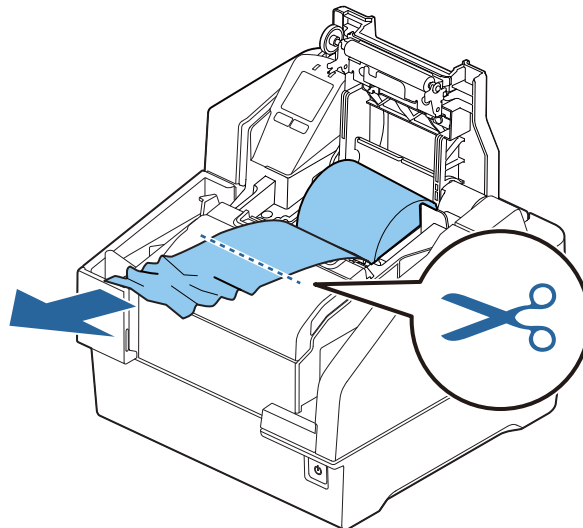

- 4** Close the roll paper cover.

Cannot Open the Roll Paper Cover

Foreign matter getting into the auto cutter can cause roll paper to jam, causing the auto cutter blade to lock without returning to its normal position. The roll paper cover will not open at this time.

Perform the procedure below to return the auto cutter blade to its normal position.

- 1 Turn off the product.**
- 2 Open the ink cartridge cover.**
- 3 Rotate the knob in the direction indicated by the arrow until the triangle mark becomes visible in the frame opening.
This lowers the auto cutter blade to its normal position.**

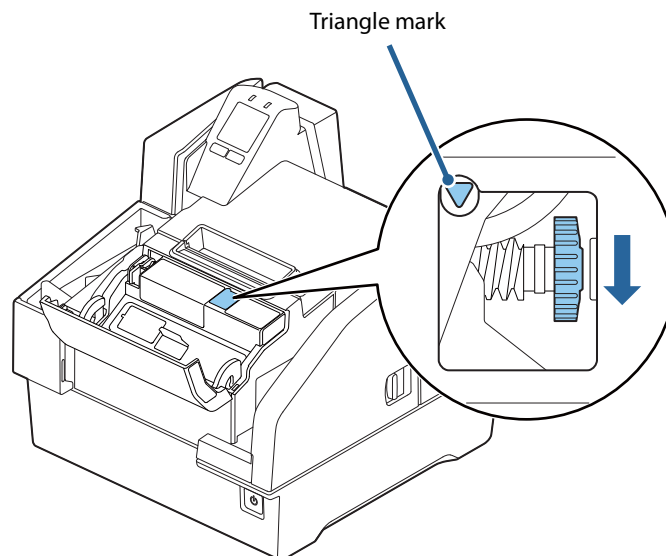

- 4 Close the ink cartridge cover.**

Problems with Print Quality

Printing on Roll Paper Is Blurred

The thermal head may be dirty. Execute thermal head cleaning.
([“Cleaning the Thermal Head and Platen Roller” on page 81](#))

Printing on Cut Sheets Is Blurry

The ink head may be clogged. Execute ink head cleaning.
([“Ink Head Cleaning” on page 82](#))

Problems with Reading Quality

Cannot Read Magnetic Ink Characters Correctly

The MICR head may be dirty. Execute MICR head cleaning.
([“Cleaning the Paper Feeding Path” on page 82](#))

Poor Cut Sheet or ID Card Reading Quality

The scanner glass may be dirty. Perform scanner cleaning.
([“Cleaning the Scanner” on page 84](#))

Product Specifications

General Specifications

Auto cutter	Cutting method	Scissors type with separated blades
	Cutting type	Partial cut (one point uncut on left end)
Number of ASF sheets		No more than 100 sheets of check paper no thicker than 0.13 mm (ANSI standard). However, total thickness should be no greater than 13 mm, including paper floating
Pocket capacity	One-pocket	No more than 100 sheets of check paper no thicker than 0.13 mm (ANSI standard). However, total thickness should be no greater than 13 mm, including paper floating
MICR reader	Magnetization method	Permanent magnet
	Supported fonts	E13B, CMC7 (Alphabetic characters not supported.)
	Recognition rate	Recognition rate no less than 99% (ANSI standard check at 25°C) False recognition rate no more than 0.1% (ANSI standard check at 25°C)
Supported OCR characters	Supported fonts	<p>OCR-A</p> <p> ABCDEFGHIJKLM NOPQRSTUVWXYZ 0123456789 - 4 5 6 </p> <p>OCR-B (Support for %, /, and & characters can be implemented by the driver)</p> <p> ABCDEFGHIJKLM NOPQRSTUVWXYZ 0123456789 - # < > +. % / & </p>
Supported bar code font		UPC-A, UPC-E, JAN13/EAN13, JAN8/EAN8, CODE39, ITF, CODE128
Interface		Ethernet Wi-Fi (available with the optional wireless LAN unit) USB ("USB Interface Specifications" on page 102)

Electrical Specifications

Power supply	Model number	AC Adapter V
	Input	100 to 240 VAC 50 to 60 Hz 1.6 A
	Output	24 VDC 2.6 A
AC power consumption (100 V to 230 V/50 to 60 Hz)*	Operating	Approx. 53.0 W
	Standby	Approx. 8.8 W

*: Average values measured based on our evaluation conditions. Values will vary according to usage conditions.

Ink Cartridge

Model number	SJIC18(K)
Color	Black



Read the precautions on handling carefully before installing the ink cartridges.
([Cautions on Ink Cartridges \(page 9\)](#))

Genuine Ink Cartridges Recommended

- For the best performance of the printer, it is recommended to use genuine Epson ink cartridges. Use of non-genuine Epson ink cartridges can adversely affect the printer and print quality and prevent the printer from realizing its maximum performance. Epson cannot guarantee the quality and reliability of non-genuine Epson products. Repairs for any damage or breakdown of this product due to the use of non-genuine Epson products will not be free of charge even if the warranty period is still valid.
- Color adjustment of the product is based on the use of genuine Epson ink cartridges. Use of non-genuine ink cartridges may result in reduced print quality. Epson recommends the use of genuine Epson ink cartridges.

Disposal of Ink Cartridges

When discarding ink cartridges, do so in accordance with the local laws, regulations, and rules of your country or geographic location.

Network Interface Specifications

For both Ethernet interface and Wi-Fi interface

Support protocols

Protocols	Usage
IP, ARP, ICMP, UDP, TCP	Basic communication protocols
LPR, TCP Socket Port	Printing protocols
HTTP/HTTPS	Used in ePOS-Print, Web Config, and Web API
SNMP, ENPC	Used in setting and monitoring
DHCP, APIPA	Used in automatic setting for the IP address and so on

NOTE

- The automatic IP addresses setting is first done using DHCP, and when DHCP is disabled or fails, APIPA is used.
- If the LAN cable is not connected for more than 40 seconds after the product is turned on, the IP address will be automatically set again after the LAN cable is connected.

Network parameters

Item	Initial settings
IP address	192.168.192.168*
Subnet mask	255.255.255.0*
Default gateway	0.0.0.0*
APIPA	Disabled
Printing IP address	Enabled
Socket Timeout	300 seconds
Community name (Read only)	public
Community name (Read/Write)	None
SNMP IP Trap 1	Disabled
SNMP IP Trap 2	Disabled
Communication mode	Auto negotiation
IP Filter	Disabled

* They are the default values when IP address acquisition is set to "Manual".

Printing communication protocol

- LPR: Transfers printing data
- TCP Socket Port: Transfers printing data and product status via bidirectional direct socket communication.

LPR

- Max. simultaneous connections: 6
- Number of connections for which printing is available: 1 (occupied until the connection is released.)
- Time out: 300 seconds (changeable)
- Job cancel: Not available
- Banner printing: Not available

Socket communication

- Port type: TCP communication port for direct printing
- Port number: 9100
- Port communication direction: bidirectional
- Max. simultaneous connections: 6
- Number of connections for which printing is available: 1 (occupied until the connection is released.)
- Time out: 300 seconds (changeable)

For Ethernet interface

Communication specifications

10BASE-T/100BASE-TX/1000BASE-T

LED Status Indication

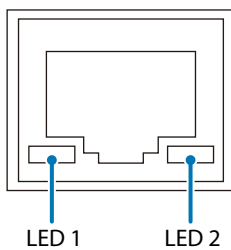

LED	LED status	Description
LED1	Lit yellow	Connecting at one of the speeds
	Blinking yellow	Sending/receiving data
	Off	Not connected
LED2	Lit green	Connecting using 1000BASE-T
	Lit orange	Connecting using 100BASE-TX
	Off	Connecting using 10BASE-T, or not connected

For Wi-Fi Interface (with OT-WL06)

NOTE

When using wireless LAN, make sure you disconnect the LAN cable. If a LAN cable is connected, wireless LAN is disabled.

Specifications

- Compliant with IEEE802.11a/b/g/n/ac (2.4 GHz or 5 GHz band).
- Infrastructure mode is supported.

Communication Standard

- IEEE802.11b (2.4 GHz)
- IEEE802.11g (2.4 GHz)
- IEEE802.11n (2.4 GHz)
- IEEE802.11a (5 GHz)
- IEEE802.11n (5 GHz)
- IEEE802.11ac (5 GHz)

Security

- WPA2-PSK
- WPA3-SAE
- WPA2/WPWA3-Enterprise

Parameter	Initial setting
Communication standard	Automatic
Network mode	Infrastructure mode
SSID	EpsonNet
Encryption type	None
Passphrase	None

Notes on Using Wi-Fi

- Install the product as far away as possible from devices that may cause radio interference, such as microwave ovens in the kitchen.
- Use channels that are away from frequency bands that cause radio interference.
- Install a shielding board between this product and devices that generate radio wave interference.
- Use a frequency band that will not cause interference, either 2.4 GHz or 5 GHz.
- When setting the auto channel of the access point, make sure that this product is not set to a channel that causes radio interference.

Before Connecting the Product via Wi-Fi

This product has not been confirmed to work with all wireless LAN devices, and operation with all wireless LAN devices is not guaranteed. Please use this product after sufficient confirmation and evaluation in advance.

Precautions for Use

When the settings of this product are initialized or changed, the product will be reset to reflect the changes. Depending on the network settings and environment, it may take approximately one minute for the changes to take effect. Also, the application may indicate that the product is turned off until it is reset. In this case, wait about one minute before connecting the product again.

In areas where Wi-Fi communication is busy, the application may misidentify that communication is disconnected and response is delayed, and indicate that the product is powered off. In this case, disabling the product's Power Save setting may improve the situation.

USB Interface Specifications

USB (Type-B)

General specification		USB 2.0
Communication speed		Hi-Speed (480 Mbps) Full-Speed (12 Mbps)
Communication method		USB bulk transmission USB interrupt transmission
Power supply specification		USB self power supply function
Current consumed by USB bus	Not equipped with MSR	Approx. 5 mA
	Equipped with MSR	Operating: 100 mA (Max.) When the PC is sleeping: Approx. 7.5 mA

Printing Specifications

Roll Paper Printing

Printing method		Line thermal
Dot density		180×180 dpi
Printing direction		Unidirectional with friction feed
Print width		72 mm, 512 dot positions
Characters per line ^{*1}	Font A	42
	Font B	56
Character spacing ^{*1}	Font A	0.28 mm (2 dots)
	Font B	0.28 mm (2 dots)
Line spacing ^{*1}		4.23 mm
Maximum printing speed ^{*2}	Text printing (with embedded fonts)	300 mm/s (when line spacing is 4.23 mm: approximately 70.9 lps)
	Page mode printing	300 mm/s
	Graphics printing in monochrome	300 mm/s
	Ladder bar code, two-dimensional symbol printing	124 mm/s
	Graphics multiple tone printing	NV/download graphics: 155 mm/s Raster graphics: 70 mm/s
Paper feed speed	Continuous paper feeding	Approximately 200 mm/s

dpi: dots per 25.4 mm (dots per inch)

*1: Command configurable

*2: The above print speed values are based on the following: 24 V, 25°C, standard density level. Printing speed is switched automatically in accordance with the voltage applied to the product and head temperature conditions. The maximum printing speed values above may not be attainable due to command combinations. If the data transfer speed is lower than the maximum printing speed, the printing speed changes, which can cause uneven print density and non-uniform feed pitch. A slow data transfer speed can also result in intermittent printing, white banding in graphics or other problems.

Cut Sheet Printing

Printing method		Line ink jet
Nozzle arrangement		360 nozzles in 2 lines
Printing color		Black
Dot density		180×180 dpi
Print height		50.8 mm
Print width		90 to 215 mm (Depends on the paper length)
Printable lines ^{*1}	Font A	12 lines maximum
	Font B	16 lines maximum
Characters per line ^{*1}	Font A	59 to 126
	Font B	78 to 169
Character spacing ^{*1}	Font A	0.28 mm (2 dots)
	Font B	0.28 mm (2 dots)
Line spacing ^{*1}		4.23 mm
Print speed ^{*2}		Approx. 1000 mm/s, approx. 600 mm/s, approx. 400 mm/s, approx. 240 mm/s

dpi: dots per 25.4 mm (dots per inch)

*1: Command configurable

*2: Depends on the type of image being acquired

Character Specifications

Fonts	Alphanumeric characters	95 characters
	Extended graphics	128 characters × 11 pages (including user-defined page)
	International characters set	16 sets
Character structure	Font A	12 × 24 (including 2-dot horizontal spacing)
	Font B	9 × 17 (including 2-dot horizontal spacing)
Character size* ¹ (W × H)	Font A	Standard: 1.41 × 3.39 mm Double-height: 1.41 × 6.77 mm Double-width: 2.82 × 3.39 mm Double-width/double-height: 2.82 × 6.77 mm
	Font B	Standard: 0.99 × 2.40 mm Double-height: 0.99 × 4.80 mm Double-width: 1.98 × 2.40 mm Double-width/double-height: 1.98 × 4.80 mm
Characters per line	Font A	Standard: 42 Double-height: 42 Double-width: 21 Double-width/double-height: 21
	Font B	Standard: 56 Double-height: 56 Double-width: 28 Double-width/double-height: 28

*1: Space between characters is not included.

Characters can be scaled up to 64 times as large as the standard sizes.

When using Font B with a font style such as emphasized, some words may be hard to read. Check the font style in advance when using Font B.

Scanner Specifications

Reading system		Contact image sensor (CIS)
Resolution (H × W)	Cut sheet	300 × 300 dpi, 240 × 240 dpi, 200 × 200 dpi, 120 × 120 dpi, 100 × 100 dpi
	ID cards	600 × 600 dpi, 300 × 300 dpi, 200 × 200 dpi
Gradation		Binary (Black and White)*1 256-level (Grayscale) 24-bit color Binary and 256-level grayscale using IR (infrared ray)
Data compression format	Binary (Black and White)*1	CCITT/group4
	256-level (Grayscale)	JPEG
Data format	Binary (Black and White)*2	TIFF*3, BMP
	256-level (Grayscale)	TIFF, JPEG, BMP, Raster
	24-bit color	TIFF, JPEG, BMP
	IR (infrared ray)	Binary (Black and White): TIFF BMP 256-level Grayscale TIFF, JPEG, BMP, Raster
Image size (H × W)*4		Max. 109.728 mm × Max. 255 mm
Image quality		In accordance with the Image Quality Assurance (IQA) standards formulated by the Financial Services Technology Consortium (FSTC)
Deskewing images		When connected via USB, image skew is corrected in accordance with the driver settings. When connected over a network, the product itself corrects the skew automatically.
Auto size adjustment		When connected via USB, the images are cropped in accordance with the driver settings. When connected over a network, the product itself crops images automatically.
Scanning speed	Cut sheet	Approx. 1000 mm/s, approx. 600 mm/s, approx. 400 mm/s, approx. 240 mm/s (depends on the image to read)
	ID card	Approx. 118 mm/s, approx. 88 mm/s (depends on the image to read)
Media specifications	Cut sheet	"Cut Sheet" on page 113
	ID card	"ID Card" on page 114

dpi: dots per 25.4 mm (dots per inch)

*1: Cut sheets only

*2: When connected via USB, the driver automatically removes the background pattern of the check when it binarizes a 256-gradation image. When connected over a network, the product itself removes the background pattern.

*3: The 200 dpi resolution, binary, CCITT (Group 4) compressed TIFF format is based on the ANSI X9.100-181-2007 standard

*4: When the driver Auto Size function is used, the cut sheet size is virtually the same size.

The acquirable image cut sheet size is 107.358 mm × 235 mm maximum. (["Scanner Scan Area" on page 113](#))

MSR (Magnetic Stripe Reader) Specifications

NOTE

Some models are not equipped with a magnetic stripe card reader (MSR).

Recognition method	Two-frequency coherent phase (F2F)	
Supported magnetic format	ISO 7811-6, AAMVA Note: Including AAMVA standard California driver's licenses	
Supported card specifications	Reading medium	ISO/IEC7810 standard
	Size (H × W)	53.92 to 54.18 mm × 85.47 to 85.90 mm
	Thickness	0.76± 0.08 mm
	Curvature	1.5 mm
Recognition rate	99.5% or more	

Paper Specifications

Roll Paper

Paper type	Thermal paper	
Size	Roll diameter	Ø83 mm maximum
	Core	Inner diameter: Ø12 mm Outer diameter: Ø18 mm Width: Same as the paper width, or within 1 mm of the paper width
	Take-up width	80 + 0.5 / - 1.0 mm
	Paper width	79.5 ± 0.5 mm
Original paper type	NTP080-80 [Original paper type: TF50KS-E Nippon Paper Industries Co., Ltd.] Japan: Nakagawa Mfg. Co., Ltd. North America: Nakagawa Mfg. (USA), Inc. Europe: Nakagawa Mfg. (EUROPE), GmbH. Southeast Asia: N.A.K. Mfg. (Malaysia) SDN BHD	
Specified original paper type	TF50KS-EY, TF60KS-E (NIPPON Paper Industries Co., Ltd.) PD160R, PD190R (Oji Imaging Media Co., Ltd.) P220AGB-1 (Mitsubishi Paper Mills Limited) AP45KS-ND, AP50KS-ND (Jujo Thermal Oy) KT55FA, KT48FA (Papierfabrik August Koehler SE) P30521, P30523, P31523, P35524 (Kanzaki Specialty Papers)	

CAUTION

- Use of roll paper whose end is glued to the core is prohibited.
- Use of thermal paper with a pre-printed recording surface should be avoided. Using it can cause the thermal head to stick to the thermal paper surface during printing, and cause printing failure and other problems. The pre-printing also can result in reduced print density. Using thermal paper with a pre-printed recording surface, pre-printing should be done in accordance with the conditions (ink type, printing and other conditions) recommended by the paper manufacturer, and the thermal paper should be checked to ensure that there is no faulty printing, loss of print density, or other problems.

Cut Sheet

Paper type	Check paper (ANSI standard), plain paper (only one sheet can be used)
Size (H × W)	60 to 120 mm × 110 to 235 mm
Paper thickness	0.075 to 0.2 mm
Paper weight	60 to 120 g/m ²

CAUTION

- Use of check paper, OCR paper, or other fine paper is recommended. Use of some paper types may result in double-feeding by the ASF or other paper feeding problems. It can also lower the capacity of the pocket.
- Use flat paper that is not curled or bent (especially the leading edge), curved, wrinkled, or other problems. Paper that is not flat can jam.
- Do not insert paper that has clips, staples, or any foreign objects affixed. Doing so can cause paper jams, MICR reading problems, damage to the MICR head or scanner head, and other problems.
- Since the paper sensor is a reflective sensor, do not use paper that has holes, that is transparency, or that has any areas with reflectance less than 40% in the position shown in the illustration below. However, fanfold paper guide holes with a diameter of 6 mm or less are not detected by the sensor.

Area where holes are not allowed and paper reflectance is no less than 40%

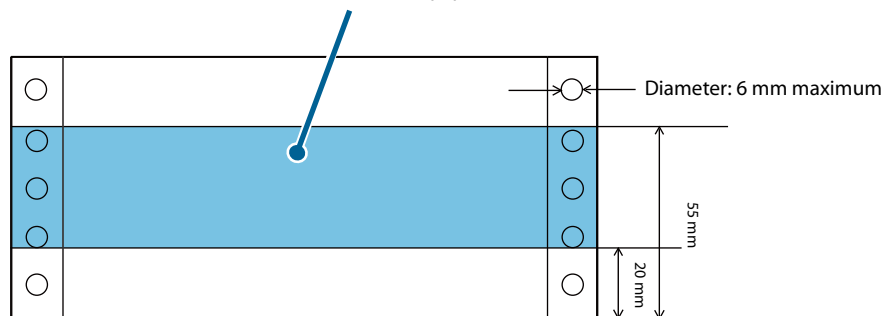

Printable Area

Roll Paper

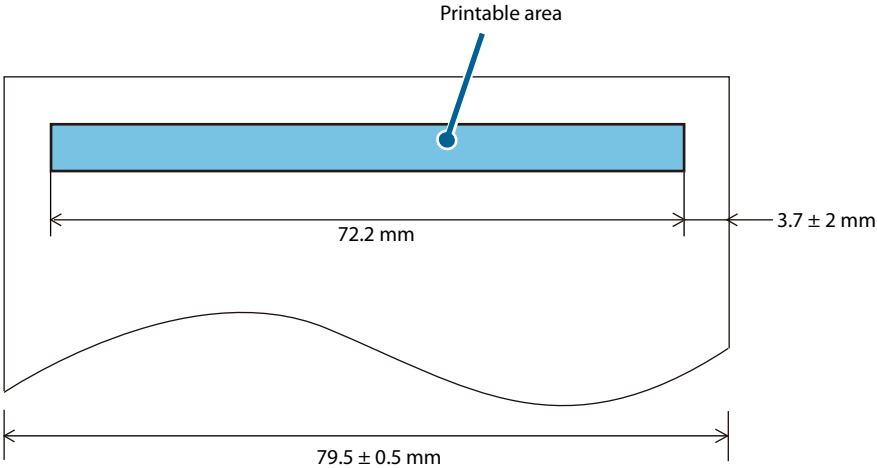

Cut Sheet

- When the print start position is based on the leading edge of the paper

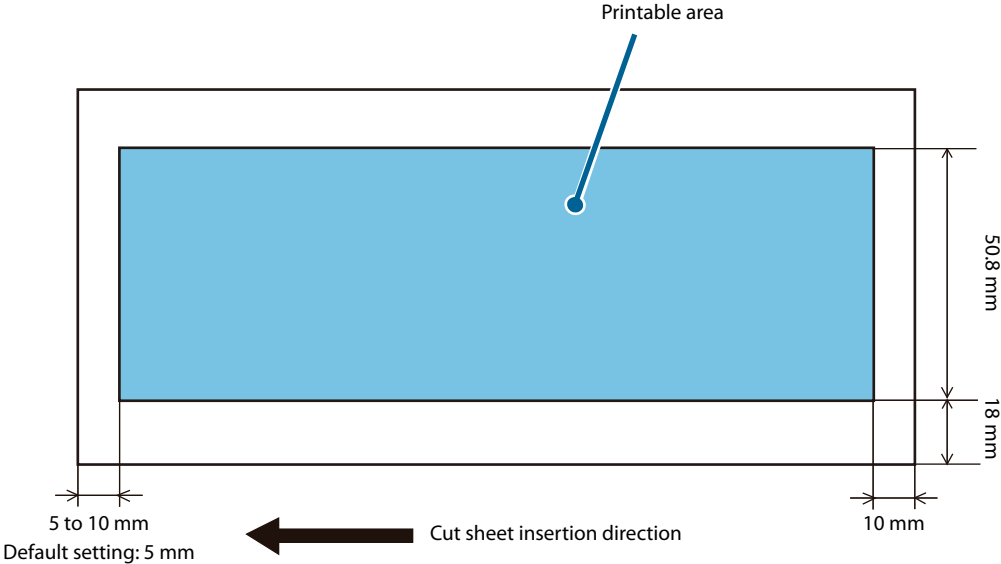

- When the print start position is based on the trailing edge of the paper

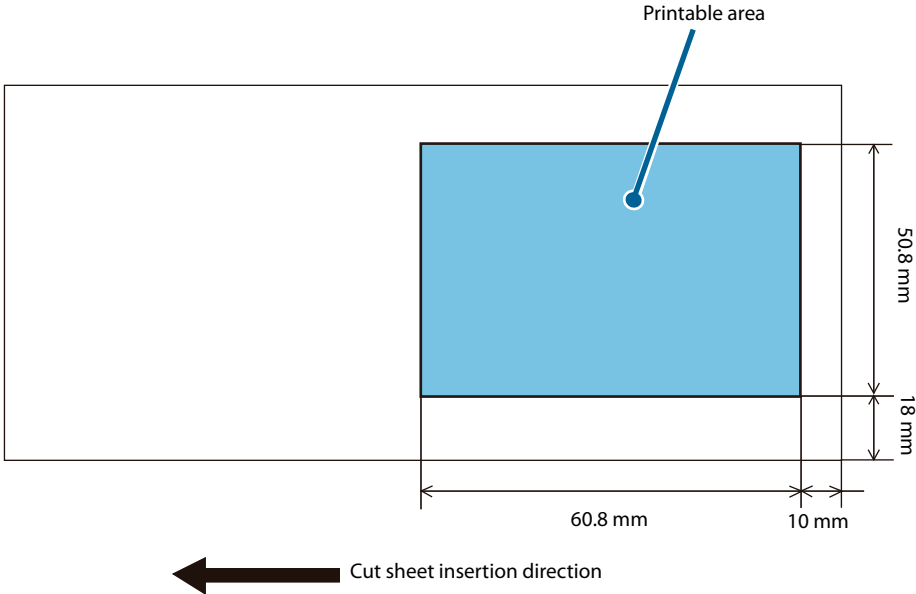

CAUTION The area that starts 40 mm from the end of the paper is printable, but the printing may be disordered.

Roll Paper Print Position and Cut Positions

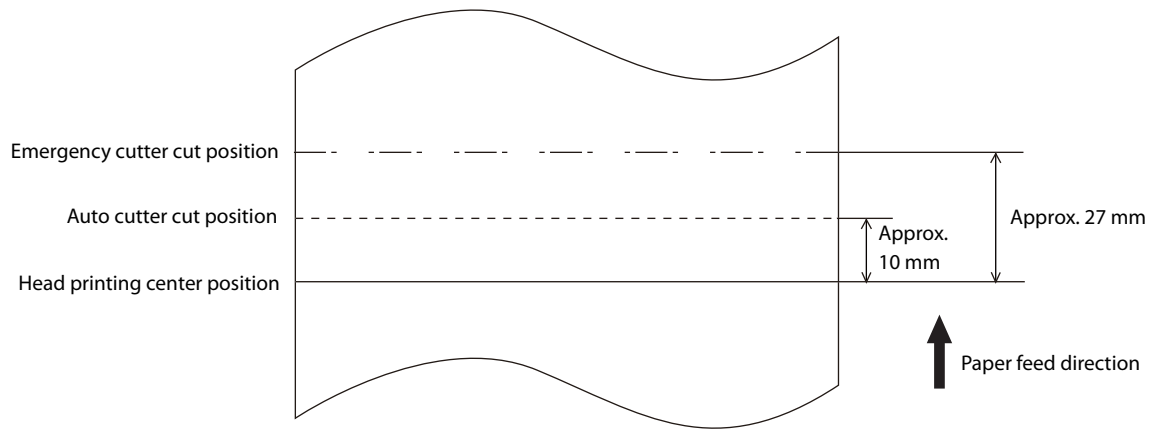
**CAUTION**

- Values are standard values. Paper slack can cause actual values to be somewhat different. For the auto cutter cut position setting, take the variation in the value into consideration.
- When removing cut paper, pulling the paper at the uncut edge can cause reduced printing pitch for the first line of the next receipt. When performing a print operation after cutting paper, it is recommended that paper be fed approximately 1 mm (14/360 inches) immediately before printing in order to prevent non-uniform pitch.
- When performing an auto cut operation after not using the product for some time, feed at least 40 mm of paper. This prevents paper jams inside the auto cutter.

Scanner Scan Area

Cut Sheet

The a and b areas in the illustration below may not be readable. The quality of the scanned image may be lower in the c area.

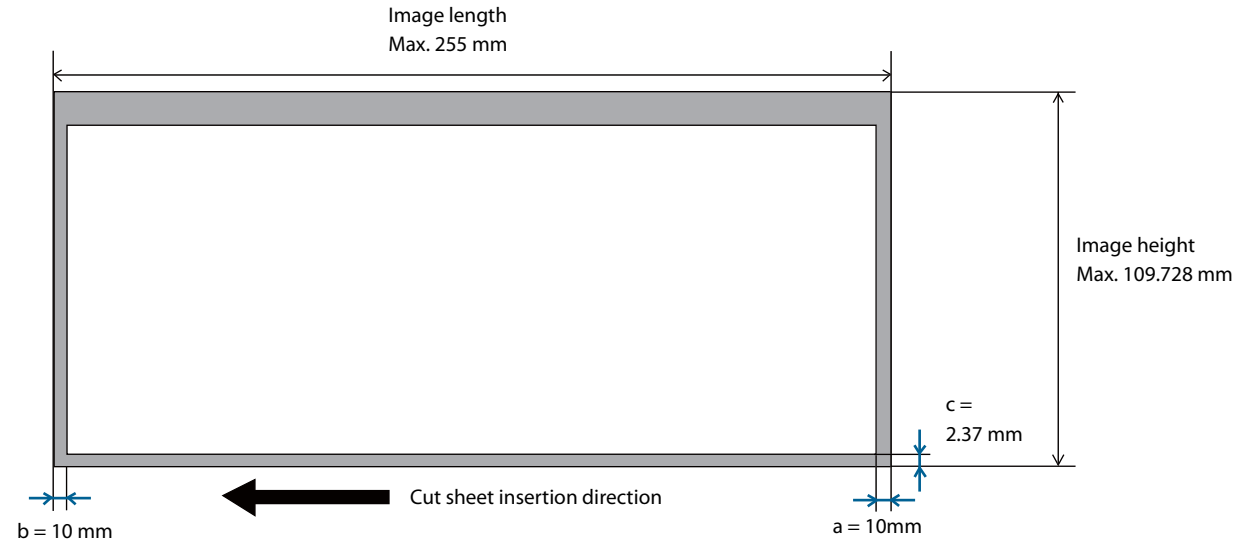
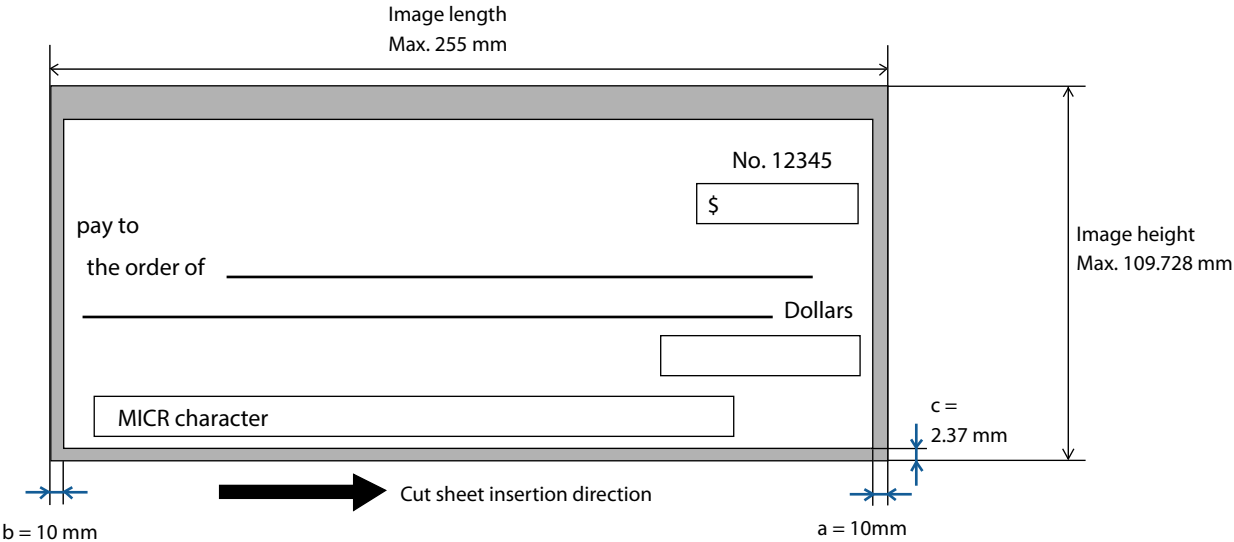

ID Card

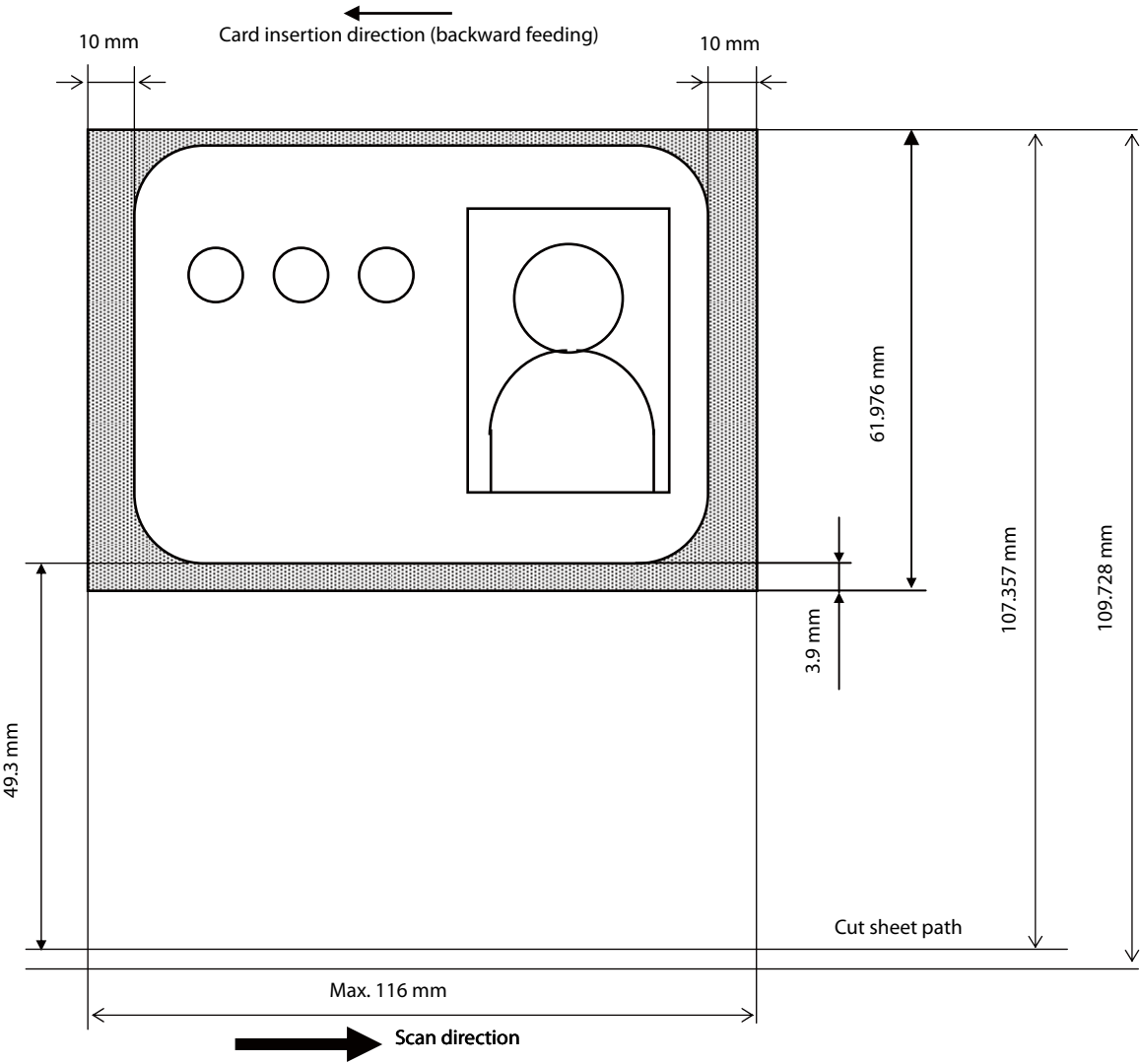

MICR Reading Area

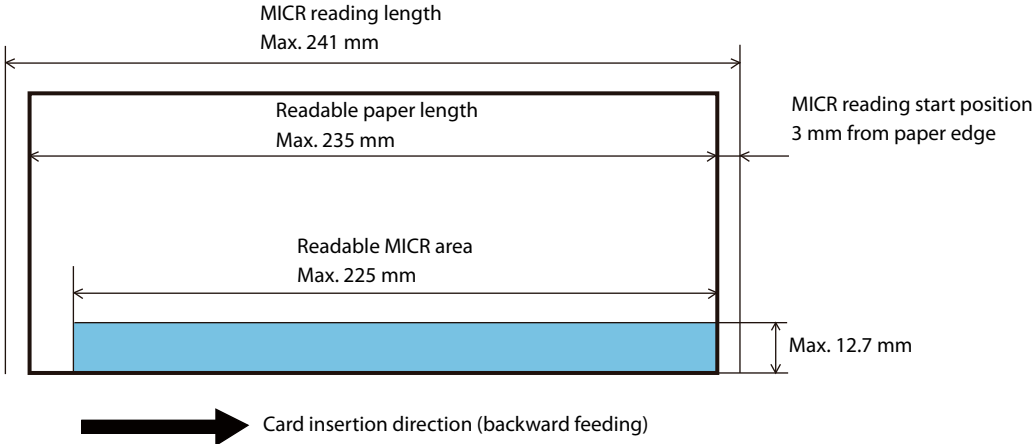

Electronic Endorsement Area

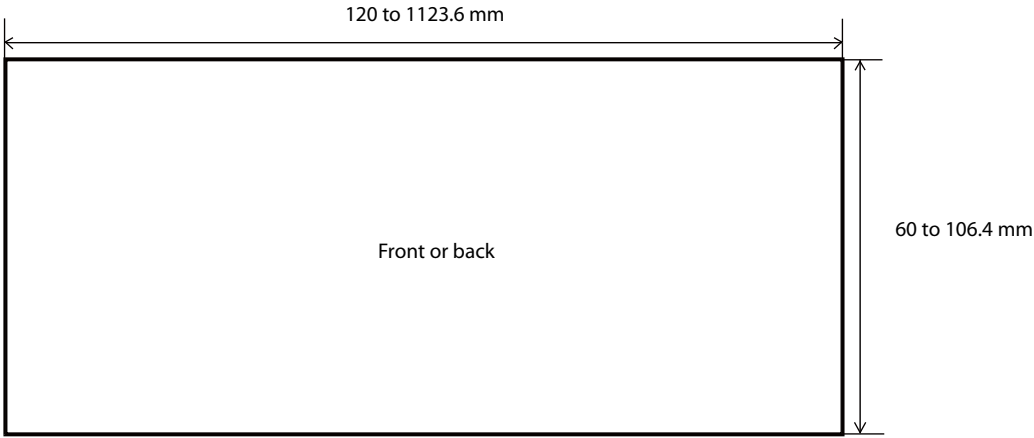

Environmental Specifications

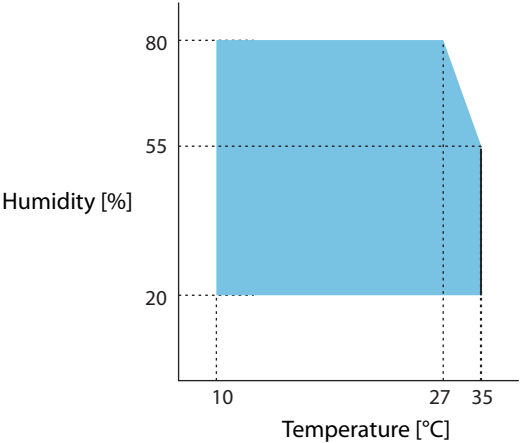
Temperature/ humidity	Operating	10 to 35°C, 20% to 80% RH, no condensation (Refer to the operating environment range in the illustration below)
	Storage	<p>Ink not charged: -20 to 60°C, 5 to 85% RH (no condensation) Within 120 H at -20°C or 60°C</p> <p>Ink charged: -20 to 40°C, 20 to 85%RH Within 120 H at -20°C Within 6 months at 0 to 30°C Within 1 month at 40°C</p> 
Pressure (elevation)		700 to 1050 hPa (approx. 0 to 2000 m above sea level)
Noise		<p>Approx. 63 dB (ANSI Bystander position)</p> <p>Note: The above noise values are measured based on our evaluation conditions. Sound values are affected by the paper being used, print contents, and setting values (print speed, print density).</p>

Reliability

Roll paper printing	Life	Printer mechanism	20 million print lines (Assuming 4.23 mm line feed, repeat of 10 lines of printing + 5 lines of paper feed.)
		Thermal head	150 million dots, 150 km
		Auto cutter	2 million cuts
	MTBF	360,000 hours	
	MCBF	96 million lines of printing	
Cut sheet processing	Life	Printer mechanism	2 million sheets (Including check and card reading, with cleaning every 100 thousand sheets.)
		ASF	2 million sheets
		Ink jet head	6 billion shots/nozzle
	MTBF	180,000 hours	
	MCBF	4.94 million processes	

Overall Dimensions

Height: 237 mm
Width: 250 mm
Depth: Pocket pulled out: 375 mm
 Pocket stowed: 264 mm
Weight: Approximately 6.1 kg

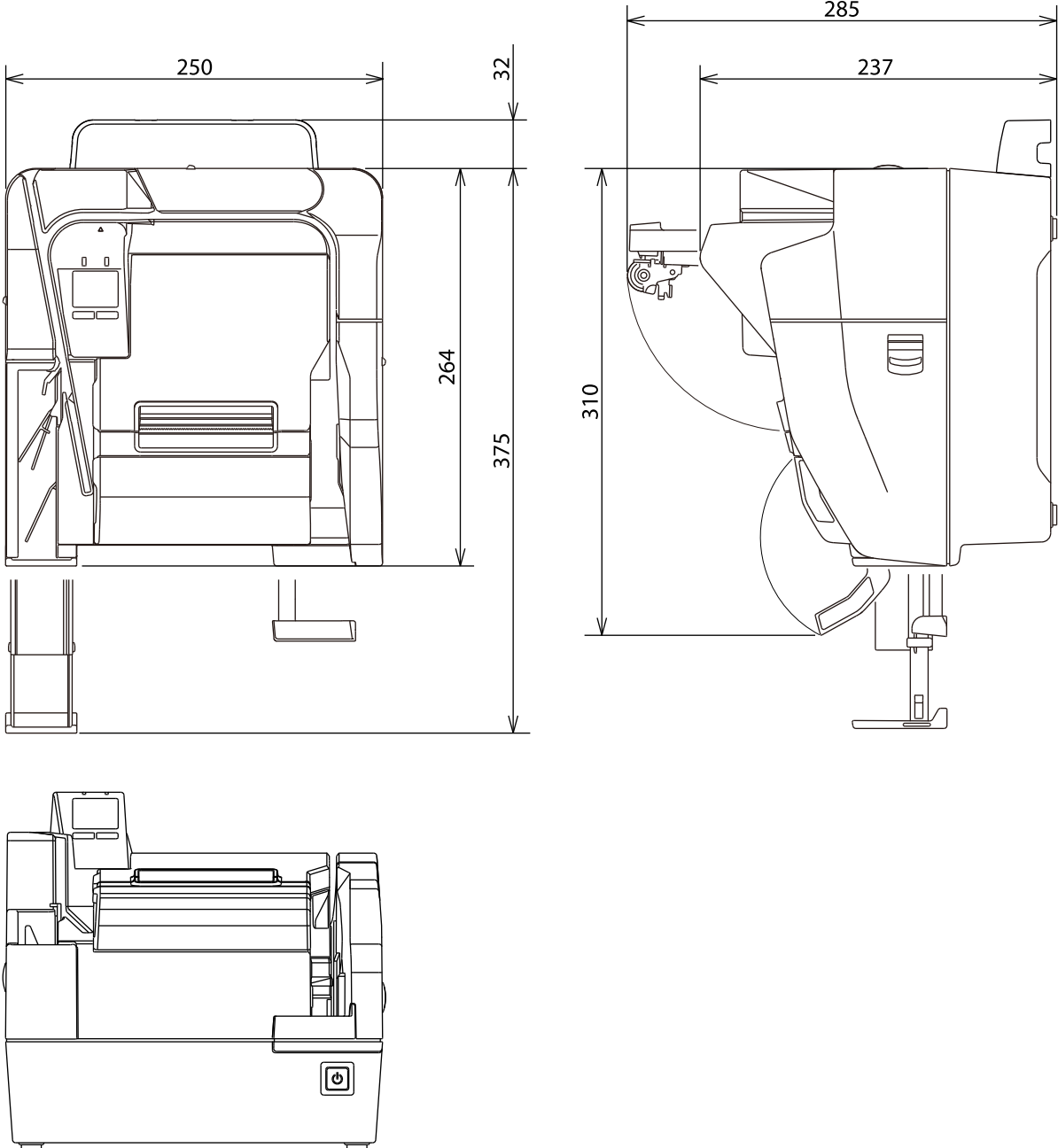

[Unit: mm]

Character Code Tables

See the Character Code Tables for TM Printers that can be accessed from the following URL:

https://support.epson.net/publist/reference_en/