

Media

Media name	Size	Part number
EPSON 360 dpi Ink Jet Paper	Letter A4	S041060/S041028 S041059/S041025
EPSON High Quality Ink Jet Paper	Letter A4	S041111 S041117
EPSON Photo Quality Ink Jet Paper	Letter A4 Legal	S041062/S041029 S041061/S041026 S041067/S041048
EPSON Photo Quality Glossy Paper	Letter A4	S041124 S041126
EPSON Photo Quality Glossy Film	Letter A4 4.1 × 5.8 (A6)	S041072 S041071 S041107
EPSON Photo Paper	4 × 6 Letter A4 Panoramic	S041134 S041141 S041104 S041145
EPSON Ink Jet Transparencies	Letter A4	S041064 S041063
EPSON Photo Quality Ink Jet Cards	4.1 × 5.8 (A6) 8 × 10	S041054 S041122
EPSON Iron-On Transfer Paper	Letter	SE41001/SE41002
EPSON Iron-on Cool Peel Transfer Paper	Letter	S041153/S041155
EPSON Photo Quality Self Adhesive Sheets	A4	S041106
EPSON Photo Stickers (refill)	4.1 × 5.8 (A6)	S041144

Accessories

Ink Cartridges

Use these EPSON ink cartridges before the expiration date on the package.

Cartridge	Part number
Black ink cartridge	S020108
Color ink cartridge	S020089

Optional Interfaces

You can install one of these EPSON printer interface boards:

Type of interface board	Model number	Compatibility
Serial	C823051	PC
32KB serial	C832071	PC
Twinax	C823151	PC
Coax	C823141	PC
LocalTalk®	C823121	Macintosh
Type B Ethernet	C823572	Macintosh/PC

Printer Specifications

Printing

Printing method On-demand ink jet
 Nozzle configuration 128 black nozzles (32 × 4, staggered)
 64 color nozzles × 3 (cyan, magenta, yellow)
 Printable columns and print speeds EPSON's fastest ink jet printer
 Up to 20% faster than the EPSON Stylus COLOR 800

Character pitch (characters per inch)	Printing column	Printing speed (characters per second)	
		Draft	LQ
10	80	533	400
12	96	640	480
15	120	800	600
17 (10 condensed)	137	912	684
20 (12 condensed)	160	1067	800

Print quality	CR speed (inches per second)
180 dpi × 180 dpi	26.7
360 dpi × 360 dpi	20
720 dpi × 720 dpi	20
1440 dpi × 720 dpi	20

Resolution	Maximum 1440 dpi × 720 dpi
Input buffer	32KB
Print direction	Bidirectional with logic seeking for text and graphics
Control code	ESC/P 2™ and expanded raster graphics code IBM XL24E emulation code
Line spacing	1/6 inch (default) programmable in 1/8-inch or 1/360-inch increments
Paper feed speed	100 milliseconds per 1/3-inch line
Character tables	1 italic and 10 graphics character tables
Character sets	14 international character sets and 1 legal character set
Bitmap fonts	<ul style="list-style-type: none"> • EPSON Roman (proportional) • EPSON Sans Serif (proportional) • EPSON Courier • EPSON Prestige • EPSON Script

Note:

All bitmap fonts are available in 10, 12, and 15 cpi. You can select other font/pitch combinations using ESC/P 2 commands.

Scalable fonts	<ul style="list-style-type: none"> • EPSON Roman • EPSON Sans Serif • EPSON Roman T • EPSON Sans Serif H
----------------	--

Note:

All scalable fonts are available in sizes from 8 to 32 points, in 2 point increments, and four styles: normal, bold, italic, and bold italic.

The printer always uses the fonts you select with your software application. You need to use the printer's internal fonts only if your application doesn't allow you to select fonts.

Ink Cartridges

Specification	Black ink cartridge (S020108)	Color ink cartridge (S020089)
Color(s)	Black	Cyan, magenta, and yellow
Print capacity*	900 pages (A4 paper; text at Normal - 360 dpi) (ISO/IEC 10561 Letter Pattern)	300 pages (A4 paper; Normal - 360 dpi, 5% each color)
Cartridge life	2 years from production date and up to within 6 months after opening package at 77 °C (25 °F)	
Storage temperature	-4 to 104 °F (-20 to 40 °C) 1 month at 104 °F (40 °C)	
Transit temperature	-22 to 140 °C (-30 to 60 °F) 1 month at 104 °F (40 °C) 120 hours at 140 °F (60 °C)	
Freezing temperature**	3.2 °F (-16 °C)	-0.4 °F (-18 °C)
Dimensions	1.09 (W) × 2.1 (D) × 1.5 (H) inches 27.8 (W) × 52.7 (D) × 38.5 (H) mm	1.7 (W) × 2.1(D) × 1.5 (H) inches 42.9 (W) × 52.7 (D) × 38.5 (H) mm

* The print capacity may vary depending on how often you use the print head cleaning function. Also, if you print large graphics and dense text with little white space, you use ink faster.

** The ink thaws and is usable after approximately 3 hours at 77 °F (25 °C).

Paper

Paper type	Size	Paper types	Thickness	Weight
Single sheets	Letter (8.5 × 11 inches) A4 (210 × 297 mm) A5 (148 × 210 mm) B5 (182 × 257 mm) Legal (8.5 × 14 inches) Half Letter (5.5 × 8.5 inches) Executive (7.5 × 10 inches)	Plain paper and special ink jet papers distributed by EPSON	0.003 to 0.004 inch (0.08 to 0.11 mm)	17 to 24 lb (64 to 90 g/m ²)
Transparencies and glossy media	Letter (8.5 × 11 inches) A4 (210 × 297 mm) A6 (105 × 148 mm, glossy film only)	Transparencies, glossy paper, and glossy film distributed by EPSON	Glossy film and transparencies: 0.0051 to 0.0059 inch (0.13 to 0.15 mm) Glossy paper: 0.0067 to 0.0071 inch (0.17 to 0.18 mm)	—
Photo paper	4 × 6 inches (102 × 152 mm) Letter (8.5 × 11 inches) A4 (210 × 297 mm) Panoramic (8.27 × 23.4 inches)	Photo Paper distributed by EPSON	—	—
Self adhesive sheets and iron-on cool peel transfer paper	A4 (210 × 297 mm) Letter (8.5 × 11 inches; iron-on cool peel transfer paper only)	Self adhesive sheets and iron-on cool peel transfer paper distributed by EPSON	0.0079 inch (0.2 mm) maximum	—
Photo stickers	A6 (105 × 148 mm) with 16 frames	Photo stickers distributed by EPSON	—	—
Envelopes	No. 10 9.5 × 4.1 inches (240 × 104 mm) DL 8.7 × 4.3 inches (220 × 110 mm) C5 4.4 × 6.4 inches (114 × 162 mm)	Plain, bond, or air mail paper	0.006 to 0.017 inch (0.016 to 0.43 mm)	12 to 20 lb (45 to 75 g/m ²)
Cards	A6 (105 × 148 mm) 8 × 10 inches (203 × 254 mm)	Ink jet cards distributed by EPSON	0.0091 inch (0.23 mm) maximum	50.7 lb (188 g/m ²)

Notes:

Since the quality of any particular brand or type of paper may be changed by the manufacturer at any time, EPSON cannot attest to the quality of any non-EPSON brand or type of paper. Always test samples of paper stock before purchasing large quantities or printing large jobs.

Poor quality paper may reduce print quality and cause paper jams and other problems. If you encounter problems, switch to a higher grade of paper.

Print on ink jet papers and envelopes only under these conditions:

Temperature: 59 to 77 °F (15 to 25 °C)

Humidity: 40 to 60% RH

Store glossy media and self adhesive sheets under these conditions:

Temperature: 59 to 86 °F (15 to 30 °C)

Humidity: 20 to 60% RH

Always load paper into the sheet feeder short edge first except envelopes. Load envelopes long edge first.

Printable areas

Single sheets and index cards

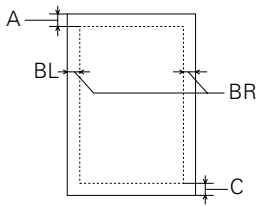

Envelopes

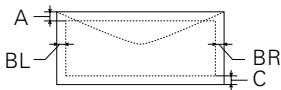

- A: The minimum top margin is 0.12 inch (3.0 mm).
When printing multiple sheets of glossy media, the minimum top margin is 1.2 inches (30 mm).
- BL: The minimum left margin is 0.12 inch (3.0 mm).
- BR: The minimum right margin is:
0.35 inch (9.0 mm) for Letter and Legal
1.10 inches (28 mm) for #10 envelopes
0.28 inch (7 mm) for DL envelopes
0.12 inch (3.0 mm) for all other paper sizes.
- C: The minimum bottom margin is 0.55 inch (14.0 mm).

Photo Paper

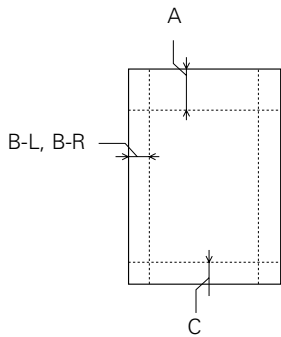

EPSON 4 × 6-inch Photo Paper
(dotted lines indicate perforations)

- A: The maximum top margin is 0.67 inch (17.0 mm).
- B-L, B-R: The maximum left and right margin is 0.24 inch (6.1 mm).
- C: The maximum bottom margin is 0.24 inch (6.1 mm).

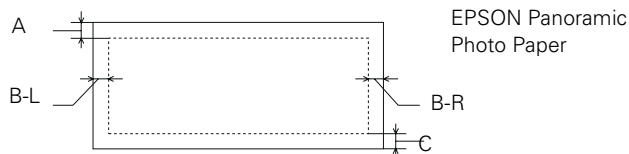

EPSON Panoramic Photo Paper

- A: The minimum top margin is 0.12 inch (3.0 mm).
- BL: The minimum left margin is 0.12 inch (3.0 mm).
- BR: The minimum right margin is 0.54 inch (14.0 mm).
- C: The minimum bottom margin is 0.12 inch (3.0 mm).

Mechanical

Paper feed method Friction, auto sheet feeder, rear entry

Sheet feeder capacity 100 sheets of 17 lb (64 g/m²) paper

Total print volume 75,000 pages (A4, text only)

Dimensions
Storage
Width: 18.7 inches (475 mm)
Depth: 10.7 inches (274 mm)
Height: 7.4 inches (177 mm)

Printing
Width: 18.7 inches (475 mm)
Depth: 24.0 inches (610 mm)
27.2 inches (692 mm, when loading transparencies)
Height: 12.4 inches (315 mm)
7.95 inches (202 mm, when loading transparencies)

Weight 14.3 lb (6.5 kg) without the ink cartridges

Electrical

Specification	120V Model	220–240V Model*
Input voltage range	103.5 to 132V	198 to 264V
Rated frequency range	50 to 60 Hz	
Input frequency range	49.5 to 60.5 Hz	
Rated current	0.4A	0.2A
Power consumption	Approx. 18 W (ISO/IEC 10561 Letter Pattern)	

* Also designed for IT power systems with Phase to Phase voltage 220–240V

Environmental

Temperature
Operation: 50 to 95 °F (10 to 35 °C)
Storage: –4 to 140 °F (–20 to 60 °C),
stored in shipping container
1 month at 104 °F (40 °C)
120 hours at 140 °F (60 °C)

Humidity
Operation: 20 to 80% RH
Storage: 5 to 85% RH (stored in shipping container, without condensation)

Safety Approvals

Safety standards UL 1950 with D3, CSA C22.2 No. 950 with D3

EMC FCC part 15 subpart B class B
CSA C108.8 class B

DOS Support

If driver support for the EPSON Stylus COLOR 850 is not available from your software manufacturer, you can use one of the other EPSON ESC/P 2 printer drivers. These drivers don't provide all the EPSON Stylus COLOR 850 features, such as 720 or 1440 dpi printing. Choose the first printer available from the following two lists:

Black printing only

- LQ-870/1170
- LQ-570(+)/1070(+)
- SQ-870/1070
- LQ-850
- LQ-500

Color and black printing

- EPSON Stylus PRO
- EPSON Stylus COLOR 500
- EPSON Stylus COLOR II
- LQ-860
- LQ-2550



Control Panel Settings

You can change the following default settings from the printer's control panel:

Setting	Options
Print direction	Auto, Bi-D, Uni-D
Font	Courier, Roman, Sans Serif, Prestige, Script, Roman T, Sans Serif H, Draft
Pitch	10 cpi, 12 cpi, 15 cpi, 17.1 cpi, 20 cpi, Proportional
I/F mode	Auto, Parallel, Serial, Option
Auto I/F wait time	10 seconds, 30 seconds
Software	ESC/P 2, IBM X24E
Auto CR (IBM mode only)	Off, On
AGM (IBM mode only)	Off, On
Character table	PC437, PC850, PC860, PC861, PC863, PC865, Abicomp, BRASCI, Roman 8, ISO Latin 1
International character set for italic table	Italic U.S.A., Italic France, Italic Germany, Italic U.K., Italic Denmark 1, Italic Sweden, Italic Italy, Italic Spain 1
Auto line feed	Off, On
Network I/F mode	Off, On
Loading position	8.5 mm, 3 mm, Others
Economy	Off, On
Parallel I/F transfer rate	Fast, Normal

Changing control panel settings

Follow these steps to change the settings listed above:

1. Make sure the printer is turned off and has paper loaded.
2. Hold down the  color cleaning button and press the  power button. The printer prints a summary of instructions for changing settings and choosing a language for the instructions.
3. Press the  color cleaning button to print a list of current settings (indicated with arrows) and additional instructions.
4. After you make the changes you want, turn the printer off to save the settings. The settings remain in effect until you change them again.

Character Tables

All character tables except Italic are the same as the PC437 table for hex codes 00 through 7F. Additional characters are available for hex codes 80 through FF. You can select the following character tables through the control panel or software commands:

- PC 437 (U.S./Standard Europe)
- PC850 (Multilingual)
- PC860 (Portuguese)
- PC861 (Icelandic)
- PC863 (Canadian-French)
- PC865 (Nordic)
- Abicomp
- BRASCI
- Roman 8
- ISO Latin 1
- Italic (no characters available for hex code 15)







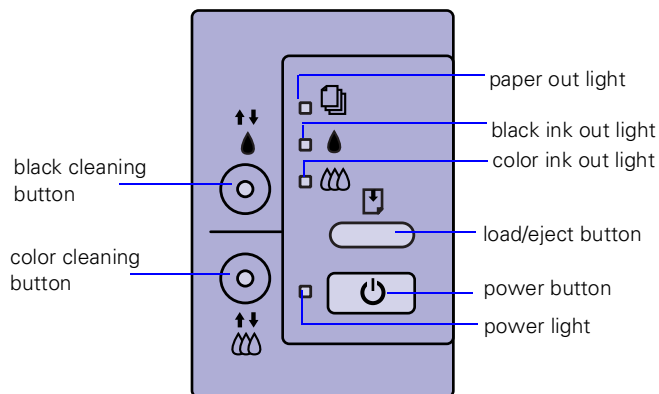

International character sets

You can select a number of international character sets with the control panel or the ESC R command. Other sets can only be selected with the ESC R command. You can select additional characters with the ESC (^ command.

Control Panel



Follow these guidelines when the control panel lights come on or flash:

-  When the paper out light *flashes*, paper is jammed in the printer. Turn off the printer and gently pull out all paper. Then press the  load/eject button.
-  When the paper out light *comes on*, your paper ran out or is incorrectly loaded. Load paper in the feeder and then press the  load/eject button.
-  When an ink out light *flashes*, your ink supply is low. Make sure you have a replacement cartridge.
-  When an ink out light *comes on*, you need to replace the ink cartridge.
-  When the power light and paper out light *flash* and all the other lights are on, your printer has a carriage error.
-  When all the lights *flash*, your printer may have an internal error.

Testing the Printer

You can run a self test to determine whether the problem comes from the printer itself or some other source.



- If the results are satisfactory, the problem lies in your software settings, the interface cable, or your computer.
- If the self test does not print correctly, you have a problem with your printer.

Follow these steps to run the test:

1. Make sure both the printer and computer are turned off.
2. Disconnect the interface cable from the printer.
3. Make sure paper is loaded in the printer.



Caution:

Load paper that's at least 8.27 inches (210 mm) wide. This prevents ink from spraying inside the printer and smudging your printouts.

4. Hold down the  load/eject button and press the  power button. Hold down the buttons until the  power light starts to flash, then release them.
5. The printer prints a nozzle check pattern (shown on page 10) and samples of fonts and colors.
6. To end the test, turn off the printer. Then reconnect the interface cable and turn on your printer and computer.

Using Hex Dump Mode

You can use the printer's hex dump mode to identify problems if you know how to interpret hex code. Follow these steps:

1. Make sure the printer is turned off and has paper loaded in it.
2. Open the cover.
3. Hold down the  load/eject button **and** the  color cleaning button and press the  power button. The printer prints **Hex Dump Mode** at the top of a page and then stops.
4. Print one or more pages from an application as usual. The printer prints the exact code it receives in hexadecimal format.
5. Turn off the printer to exit hex dump mode.

Installing Ink Cartridges for the First Time

Follow these steps to install the ink cartridges that came in the box with the printer for the first time:

1. Make sure the printer is turned off (the  power button should be up). Then plug the printer's power cord into a grounded outlet.

Caution:

Always use the  power button to turn the printer on or off. Never use an external switch—such as a power strip switch—to turn off the printer.

Don't use an outlet that can be turned off by a wall switch or timer, or one that uses the same circuit as a large appliance. This may disrupt the power, which can erase memory or even damage the printer's power supply.



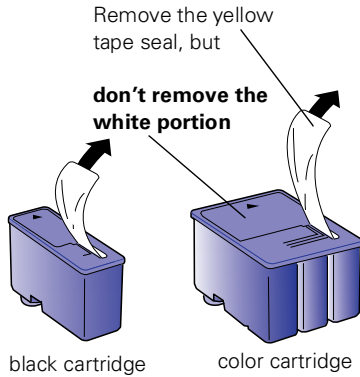

- Open the ink cartridge packages that came with your printer. Then remove **only** the yellow part of the tape seal on the top of each one. **Don't pull off the white portion or try to remove the clear seal underneath the cartridge.**



Caution:
Install the ink cartridges that came with the printer to ensure the print heads charge correctly.

You must remove the yellow tape from the top of the cartridge or you will permanently damage it. It's okay if a small corner of the yellow tape stays on the cartridge.

Warning:
If ink gets on your hands, wash them thoroughly with soap and water. If ink gets into your eyes, flush them immediately with water.

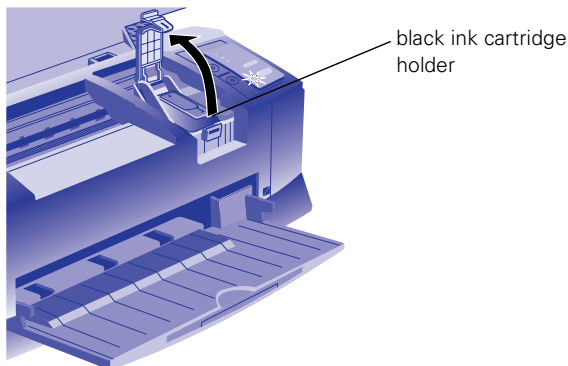

- Press the  power button to turn on the printer. The  power light flashes and the  and  ink out lights come on. The black ink cartridge holder moves into loading position.
- Open the printer cover and lift up the black ink cartridge clamp.



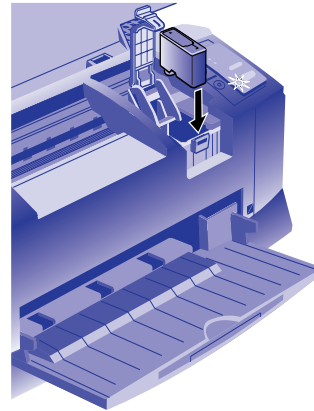

- Place the black ink cartridge in the holder with the arrow on the top label facing the back of the printer. Then close the clamp, making sure it clicks into place.





Caution:
If the ink cartridge holder moves back to the right before you install the cartridge, don't try moving it back by hand. Press the  black cleaning button and hold it down for 3 seconds to move the holder back into position.

- Now press the  color cleaning button to move the color ink cartridge holder into loading position.
- Repeat steps 4 and 5 to install the color ink cartridge. Then press the  load/eject button to begin charging the ink delivery system.

Charging takes up to 4 minutes. The  power light flashes and the printer makes various sounds until it's finished. Don't turn off the printer or interrupt the charging process or it will start over, using more ink than necessary.

Caution:
Never turn off the printer when the  power light is flashing, unless the printer hasn't moved or made any noise for more than 10 minutes.

Removing and Installing an Ink Cartridge

When the  black or  color ink out light flashes, the indicated cartridge is low on ink. This is a good time to make sure you have a new cartridge. When the light stays on, the cartridge is empty and you need to replace it.

Use these EPSON ink cartridges within six months of installing them and before the expiration date on the package:



Black ink cartridge:S020108



Color ink cartridge:S020089

When you need new ink cartridges, contact your dealer or call EPSON Accessories at (800) 873-7766 (U.S. only). In Canada, please call (800) 873-7766 for dealer referral.



When the  color ink out light comes on, you can continue to print with black ink. Simply turn the printer off and then back on again. When you print, make sure you choose **Black** as the Ink setting in your printer software.

Removing an Empty Ink Cartridge

You can replace a cartridge when the  black or  color ink out light is either flashing or on. Make sure the printer is turned on and not printing before you start. Then follow these steps:

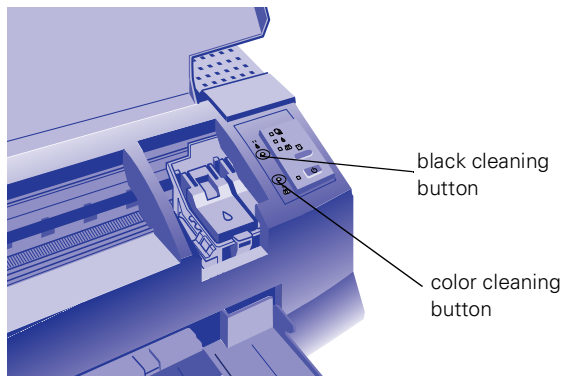
1. Determine which cartridge needs to be replaced.
2. Lower the output tray and raise the printer cover. Then locate the  black and  color cleaning buttons next to the control panel under the printer's cover.



3. Press the  black or  color cleaning button and hold it for three seconds.

Caution:

If you press a cleaning button when no ink out light is flashing or on, the printer cleans the print heads, as described on page 9. If you need to replace an ink cartridge before the lights flash (because the ink is too old, for example) follow the instructions under "Replacing an Outdated Ink Cartridge" on page 9.

The print heads move slightly left and the  power light begins flashing. (The print heads return to their home position if you don't proceed to step 4 within 60 seconds.)

Caution:

To avoid damaging the printer, never move the print heads by hand.

4. Pull up the ink cartridge clamp. The cartridge rises up from its holder. (Although the illustration shows the black ink cartridge, the procedure is the same for replacing the color ink cartridge.)

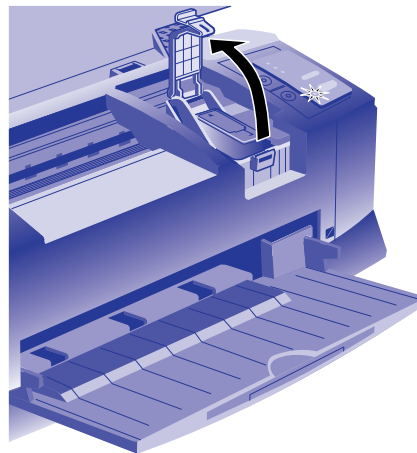

Caution:

Don't open the clamp or remove a cartridge except to replace it with a new one. Once you remove a cartridge, you can't reuse it, even if it contains ink.

5. Lift the cartridge out of the printer and dispose of it carefully.

Warning:

If ink gets on your hands, wash them thoroughly with soap and water. If ink gets into your eyes, flush them immediately with water.

6. Follow the steps in the next section to install the new ink cartridge.

Installing the New Cartridge

Once you have removed the empty cartridge, you're ready to install the new one. Follow these steps:

1. Remove the new ink cartridge from its packaging.
2. Remove **only** the yellow part of the tape seal on top as shown below. **Don't pull off the white portion or try to remove the clear seal underneath the cartridge.**

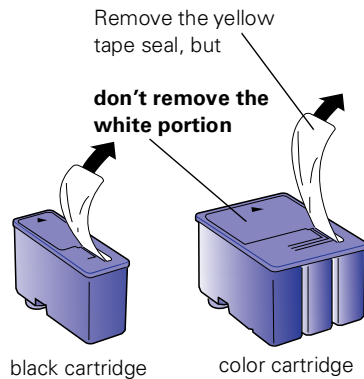

Caution:

You must remove the yellow tape from the top of the cartridge or you will permanently damage it. It's okay if a small corner of the yellow tape stays on the cartridge. Do not remove the clear seal from the bottom of the cartridge; ink will leak out.

3. Lower the ink cartridge into its holder with the label facing up and the arrow pointing to the back of the printer.

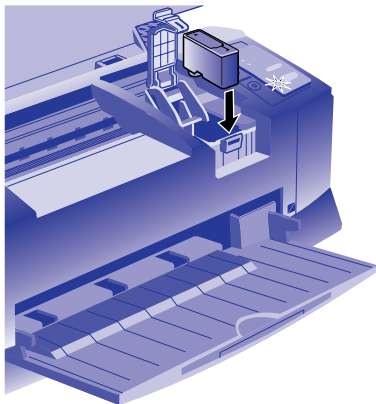

4. Press down the ink cartridge clamp until it locks in place.
5. If you need to replace the other ink cartridge, follow the steps under "Removing an Empty Ink Cartridge," and then steps 1 through 4 under "Installing the New Cartridge."
6. Press the  load/eject button and close the printer cover.

The printer moves the print heads and begins charging the ink delivery system. (Even if you don't press the button, ink charging begins 60 seconds after you close the clamp.)



The  power light flashes, and the printer makes various sounds. Charging takes about three minutes. When it's finished, you can print again.



Caution:

Never turn off the printer when the  power light is flashing, unless the printer hasn't moved or made any noise for more than 10 minutes.

Replacing an Outdated Ink Cartridge



If an ink cartridge is more than six months old, you may need to replace it. How can you tell? You may notice that your printouts don't look as good as they used to. If print quality doesn't improve after cleaning and aligning the print heads, you can replace one or both cartridges.

Follow these steps to replace an ink cartridge before the  black or  color ink out light is flashing or on:

1. Make sure the printer is turned on and not printing.
2. Lower the output tray and raise the printer cover. Then locate the  black and  color cleaning buttons next to the control panel under the printer's cover.

Caution:

To avoid damaging the printer, never move the print heads by hand.

3. Press **both** the  black and  color cleaning buttons and hold them down for a few seconds until the black print head moves to the left.
 - To replace the black ink cartridge, follow the instructions beginning with step 4 on page 8.
 - To replace the color ink cartridge, press the  color cleaning button and hold it down for a few seconds. After the color ink cartridge moves to the left, follow the instructions beginning with step 4 on page 8.

Cleaning the Print Heads



If your printed image is unexpectedly light or faint, or dots are missing from the image, you may need to clean the print heads. This unclogs the nozzles so they can deliver ink properly.

Cleaning the print heads uses ink, so clean them only if print quality declines. You can clean the print heads in either of the following ways:

- With the Head Cleaning utility in your printer software (when the printer is on a local port, not on a network)
- Using the printer's control panel buttons

Using the Head Cleaning Utility

Follow these steps to run the utility from a Windows computer or a Macintosh:

1. Make sure the printer is turned on but not printing, and the  black and  color ink out lights are off.
2. Access the printer settings dialog box.
3. Click the **Utility** tab (Windows) or the **Utility** button (Macintosh). You see the Utility menu.
4. Click the **Head Cleaning** icon.
5. Follow the instructions on the screen to clean one or both print heads. Cleaning each head takes about two minutes, during which the printer makes some noise and the  power light flashes.

When the power light stops flashing, you need to run a nozzle check to test the print quality and reset the cleaning cycle.

Caution:







Never turn off the printer when the  power light is flashing, unless the printer hasn't moved or made any noise for more than 10 minutes.

6. Make sure paper is loaded in the printer and click **Print nozzle check pattern** (Windows) or **Confirmation** (Macintosh). Then click **Next**. See "Examining the Nozzle Check Pattern" for instructions.

If your print quality has not improved, repeat the steps above. If you don't notice any improvement after doing this two or three times, check the print quality solutions in the *User's Guide*.

Using the Control Panel

Follow these steps to clean the print heads:

1. Make sure the printer is turned on and not printing, and that the  black and  color ink out lights are off.
2. Open the printer cover, then press the  black or  color cleaning button and hold it for three seconds. Cleaning takes about two minutes, during which the printer makes some noise and the  power light flashes.
3. When the  power light stops flashing, repeat step 3 for the other print head if necessary.

Caution:

Never turn off the printer when the  power light is flashing, unless the printer hasn't moved or made any noise for more than 10 minutes.

4. After you're finished cleaning and the  power light stops flashing, you need to print a page to test the print quality and reset the cleaning cycle. If you're connected directly to the printer, run a nozzle check. Go to step 5.

If you're using DOS or a network interface card, open an application and print a document containing black and color data. Then go to step 7.

5. Access the printer settings dialog box. Then click the **Utility** tab (Windows) or the **Utility** button (Macintosh). You see the Utility menu.
6. Click the **Nozzle Check** icon, then click **Next**. See the next section for instructions on examining the nozzle check pattern.
7. If your print quality has not improved, repeat the steps above. If you don't notice any improvement after doing this two or three times, check the print quality solutions in the *User's Guide*.

Examining the Nozzle Check Pattern

Examine the nozzle check pattern you print. It should look something like this, with the lower pattern colored cyan, magenta, and yellow:

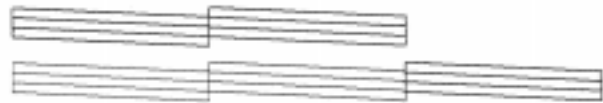

Each staggered horizontal and straight vertical line should be complete, with no gaps in the dot pattern. If your printout looks okay, you're done. If any dots are missing, as illustrated below, clean the print heads again.

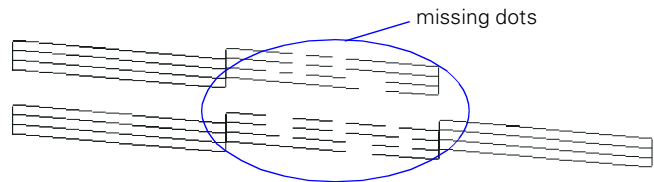

Aligning the Print Heads

If your printouts contain misaligned vertical lines, you may need to align the print heads. You can align the print heads in either of the following ways:

- With the Print Head Alignment utility in your printer software (when the printer is connected to a local port only)
- Using the printer's control panel buttons

Using the Print Head Alignment Utility

Follow these steps to run the utility (Windows or Macintosh):

1. Make sure the printer is turned on and paper is loaded.

Caution:

Load paper that's at least 8.27 inches (210 mm) wide. This prevents ink from spraying inside the printer and smudging your printouts. For the best results, load EPSON ink jet paper to check your alignment.

2. Access the printer settings dialog box.
3. Click the **Utility** tab (Windows) or the **Utility** button (Macintosh). You see the Utility menu.
4. Click the **Print Head Alignment** icon.
5. Follow the instructions on the screen to print a test page and select the correct alignment.



Using the Control Panel to Align the Print Heads

Follow these steps to align the print heads:

1. Make sure the printer is turned off and paper is loaded. Then open the printer cover.

Caution:

Load paper that's at least 8.27 inches (210 mm) wide. This prevents ink from spraying inside the printer and smudging your printouts. For the best results, load EPSON ink jet paper to check your alignment.

2. Hold down the  load/eject button and the  black cleaning button and turn on the printer. Then release the buttons. After a moment, the printer prints an instruction sheet telling you how to select a language for the alignment instructions.
3. Press the correct control panel buttons as instructed to select a language. The printer prints instructions for aligning the print heads.
4. Follow the instructions on the sheet to align the print heads. When you're finished, turn off the printer to exit the alignment mode.

Using Special Media

When you print on special media, you need to be careful about choosing the correct **Media Type** and **Paper Size** settings in your printer software. The table on the following page lists the available EPSON media and the corresponding **Media Type** setting for each one in your printer software.

Media name	Size	Media Type setting
EPSON 360 dpi Ink Jet Paper	A4 Letter	360 dpi Ink Jet Paper
EPSON Iron-on Cool Peel Transfer Paper	Letter	
EPSON Special Coated Paper for 360 dpi Printing	Letter	
EPSON High Quality Ink Jet Paper	A4 Letter	Photo Quality Ink Jet Paper
EPSON Photo Quality Ink Jet Paper	A4 Letter Legal	
EPSON Special Coated Paper for 720 dpi Printing	Letter	
EPSON Photo Quality Ink Jet Cards	4.1 × 5.8 (A6) 8 × 10	
EPSON 720 dpi Index Card	4.1 × 5.8 (A6)	Photo Paper
EPSON Photo Quality Self Adhesive Sheets	A4	
EPSON Photo Quality Glossy Paper	A4 Letter	
EPSON Photo Paper	4 × 6 A4 Letter Panoramic	
EPSON Photo Quality Glossy Film	A4 Letter 4.1 × 5.8 (A6)	
EPSON High Quality Glossy Paper	Letter	
EPSON Photo Stickers (refill)	4.1 × 5.8 (A6)	
EPSON Ink Jet Transparencies	A4 Letter	Ink Jet Transparencies
EPSON Iron-On Transfer Paper	Letter	

Transporting the Printer

If you need to transport your printer some distance, you should repack it in its original box. Follow these steps:

1. Turn on the printer and wait until the print heads lock in the far right position. Then turn off the printer.
2. Unplug the power cord from the electrical outlet. Then disconnect the interface cable from the printer.

Caution:

To avoid damage, always leave the ink cartridges installed when transporting the printer.

3. Remove any paper from the printer and remove the paper support.
4. Push in the output tray extensions and close the tray.
5. Repack the printer and attachments in the original box using the protective materials that came with it. See the Notice Sheet that was packed with the printer.

Be sure to keep the printer level as you transport it. If you notice a decline in print quality after transporting the printer, clean the print heads; if output is misaligned, align the print heads.

Related Documentation

TM-STYCLR850	EPSON Stylus COLOR 850 Service Manual
PL-STYCLR850	EPSON Stylus COLOR 850 Parts Price List
CPD-6236	EPSON Stylus COLOR 850 User's Guide
CPD-6233	EPSON Stylus COLOR 850 Start Here card
CPD-6234	EPSON Stylus COLOR 850 CD-ROM jacket