

Media

Media name	Size	Part number
EPSON 360 dpi Ink Jet Paper	Letter A4	S041060 S041059
EPSON High Quality Ink Jet Paper	Letter A4	S041111 S041117
EPSON Photo Quality Ink Jet Paper	Letter A4 Legal	S041062 S041061 S041067
EPSON Matte Paper - Heavyweight	Letter	S041257
EPSON Photo Quality Glossy Paper	Letter A4	S041124 S041126
EPSON Photo Quality Glossy Film	Letter A4 A6	S041072 S041071 S041107
EPSON Photo Paper	Letter A4 4 x 6 Panoramic (8.3 x 23.4 inches)	S041141 S041140 S041134 S041145
EPSON Ink Jet Transparencies	Letter A4	S041064 S041063
EPSON Photo Quality Ink Jet Cards	A6 8 x 10	S041054 S041122
EPSON Photo Stickers Kit (CD-ROM and paper)	A6; 16 frames	S041144-KIT
EPSON Photo Stickers (refill)	A6; 16 frames	S041144
EPSON Iron-On Cool Peel Transfer Paper	Letter	S041153/ S041155
EPSON Photo Quality Self Adhesive Sheets	A4	S041106

Accessories

Ink Cartridges

Cartridge	Part number
Black	S020189
Color	S020191

User Replaceable Parts

Part name	Part number
Blueberry cover	NEED PART NUMBERS
Grape cover	
Lime cover	
Strawberry cover	
Tangerine cover	

DO WE NEED TO LIST THESE PARTS?

Specifications

Printing

Printing method	On-demand ink jet
Nozzle configuration	144 black nozzles 144 color nozzles (48 cyan, 48 magenta, 48 yellow)
Resolution	Maximum 1440 x 720 dpi
Input buffer	64KB
Print direction	Bidirectional with logic seeking
Control code	ESC/P 2 raster and EPSON Remote

Paper

Paper type	Size	Paper types	Thickness	Weight
Single sheets	Letter (8.5 × 11 inches) Legal (8.5 × 14 inches) Half letter (statement, 5.5 × 8.5 inches) Executive (7.5 × 10 inches) A4 (210 × 297 mm) A5 (148 × 210 mm) B5 (182 × 257 mm)	Plain paper and special ink jet papers distributed by EPSON	0.003 to 0.004 inch (0.08 to 0.11 mm) for plain bond paper	17 to 24 lb (64 to 90 g/m ²)
Transparencies, Glossy film, Glossy paper	Letter (8.5 × 11 inches) A4 (210 × 297 mm) A6 (105 × 148 mm), glossy film only	Transparencies, glossy paper, and glossy film distributed by EPSON	—	—
Self-adhesive sheets	A4 (210 × 297 mm)	Self adhesive sheets distributed by EPSON	—	—
Envelopes	No. 10, 9.5 × 4.1 inches (240 × 104 mm) DL, 8.7 × 4.3 inches (220 × 110 mm) C6, 4.4 × 6.4 inches (114 × 162 mm)	Plain bond paper or air mail paper	0.006 to 0.02 inch (0.16 to 0.52 mm)	12 to 20 lb (45 to 75 g/m ²)
Ink jet cards	A6 (105 × 148 mm) 8 × 10 inches	Ink jet cards distributed by EPSON	—	—
Photo paper	Letter (8.5 × 11 inches) A4 (210 × 297 mm) 4 × 6 inches (102 × 152 mm) Panoramic (210 × 594 mm)	Photo paper distributed by EPSON	—	—
Photo stickers	A6 (105 × 148 mm) with 16 frames	Photo stickers distributed by EPSON	—	—
Iron-On Cool Peel transfer paper	Letter (8.5 × 11 inches)	Transfer paper distributed by EPSON	—	—
Matte paper - Heavyweight	Letter (8.5 × 11 inches) A4 (210 × 297 mm)	Matte paper distributed by EPSON	—	—

Note:

Since the quality of any particular brand or type of paper may be changed by the manufacturer at any time, EPSON cannot attest to the quality of any non-EPSON brand or type of paper. Always test samples of paper stock before purchasing large quantities or printing large jobs.

Poor quality paper may reduce print quality and cause paper jams and other problems. If you encounter problems, switch to a higher grade of paper.

Print only under these conditions:

Temperature: 59 to 77 °F (15 to 25 °C)
Humidity: 40 to 60% RH

Store glossy film and self adhesive sheets under these conditions:

Temperature: 59 to 86 °F (15 to 30 °C)
Humidity: 20 to 60% RH

Printable Area

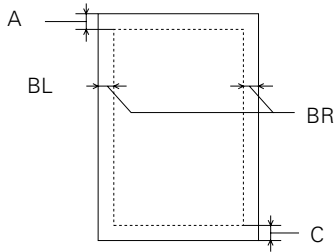

Single sheets and cards

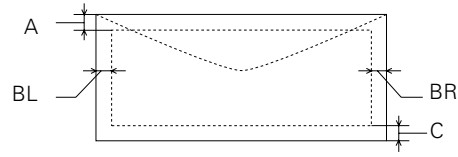

Envelopes

- A The minimum top margin is 0.12 inch (3.0 mm). When printing multiple sheets of EPSON Photo Quality Glossy Film, the minimum top margin is 1.2 inches (30 mm).
- BL The minimum left margin is 0.12 inch (3.0 mm).
- BR The minimum right margin is:
 1.10 inches (28 mm) for #10 envelopes
 0.28 inch (7.0 mm) for DL envelopes
 0.12 inch (3.0 mm) for all other paper sizes.
- C The minimum bottom margin is 0.55 inch (14.0 mm) using the Standard printable area setting. This can be decreased to 0.12 inch (3.0 mm) using the Maximum printable area setting. However, the print quality in the expanded printable area may be reduced.

Note:

Always load paper into the paper feeder short edge first except envelopes. Load envelopes long edge first.

Ink Cartridges

Specification	Black ink cartridge (S020189)	Color ink cartridge (S020191)
Color(s)	Black	Cyan, magenta, and yellow
Print capacity*	900 pages text (ISO/IEC 10561 letter pattern) 300 pages graphic (5% coverage)	300 pages (5% coverage each color)
Cartridge life	2 years from production date and up to within 6 months after opening package at 77 °F (25 °C)	
Storage temperature	-4 to 104 °F (-20 to 40 °C) 1 month at 104 °F (40 °C)	
Transit temperature	-22 to 140 °F (-30 to 60 °C) 1 month at 104 °F (40 °C) 120 hours at 140 °F (60 °C)	
Freezing temperature**	3.2 °F (-16 °C)	-0.4 °F (-18 °C)
Dimensions	1.09 (W) × 2.1 (D) × 1.5 (H) inches 27.8 (W) × 52.7 (D) × 38.5 (H) mm	1.7 (W) × 2.1 (D) × 1.5 (H) inches 42.9 (W) × 52.7 (D) × 38.5 (H) mm

* The print capacity may vary depending on how often you clean the print head.

** The ink thaws and is usable after approximately 3 hours at 77 °F (25 °C).

Caution:

To ensure good results, use genuine EPSON cartridges and do not refill them. Other products may cause damage to your printer not covered by EPSON's warranty.

Do not use an ink cartridge after the expiration date on the package.

Mechanical

Paper feed method Friction with paper feeder, rear entry

Paper feeder capacity Maximum 100 sheets of 17 lb (64 g/m²) paper

Dimensions

Storage
 Width: 17.2 inches (437 mm)
 Depth: 15.1 inches (383 mm)
 Height: 11.8 inches (300 mm)

Printing
 Width: 17.2 inches (437 mm)
 Depth: 24.3 inches (618 mm)
 Height: 11.8 inches (300 mm)

Weight 16.5 lb (7.5 kg) without the ink cartridges

Scanning

Scanner type Sheet-fed color image scanner

Photoelectric device Color CCD line sensor

Effective pixels 2550 × 4200 pixels (300 dpi)

Document size 8.5 × 14 inches (216 × 355.6 mm)
 (The reading area can be specified from your software.)

Scanning resolution 300 dpi (main)
 600 dpi (sub)

Output resolution 50 to 4800 dpi

Color separation RGB color filters on CCD

EPSON Stylus Scan 2000

Image data	12 bits per pixel per color internal 8 bits per pixel per color external
Brightness	7 levels
Line art settings	Fixed threshold [CORRECT?] Text Enhancement Technology
Halftoning process	AAS (Auto Area Segmentation)
Gamma correction	Printer 3 level (A, B, C) User defined 1 level
Interface	USB 1.0 + IEEE 1284.4
Light source	White cold cathode fluorescent lamp
Reliability	Main unit life: 10,000 pages Lamp life: 10,000 hours

Electrical

Specification	120V model	240V model
Input voltage range	99V to 132V	198V to 264V
Rated frequency range	50 to 60 Hz	
Input frequency range	49.5 to 60.5 Hz	
Rated current	0.6A	0.4A
Power consumption	Approx. 29 W (ISO 10561 Letter Pattern)	

Environmental

Temperature	Operation: 50 to 95 °F (10 to 35 °C)
	Storage*: -4 to 104 °F (-20 to 40 °C) 1 month at 104 °F (40 °C)
Humidity	Transit*: -4 to 140 °F (-20 to 60 °C) 120 hours at 140 °F (60 °C)
	Operation: 20 to 80% RH Storage*: 5 to 85% RH (without condensation)

* Stored in shipping container

Safety Approvals

Safety standards	UL 1950 with D3, CSA 22.2 No. 950
EMC	FCC part 15 subpart B class B

Interfaces

USB interface

Specification	Description
Standard	Based on Universal Serial Bus Specifications Revision 1.0, Universal Serial Bus Device Class Definition for Printing Devices Version 1.0
Bit rate	12 Mbps (full speed device)
Data encoding	NRZI
Adaptable connector	USB Series B
Recommended cable length	6.5 feet (2 meters) maximum

Parallel interface

Forward channel

Specification	Description
Data format	8-bit parallel, IEEE-1284 compatibility mode
Synchronization	Refer to the IEEE-1284 specification
Handshake timing	Refer to the IEEE-1284 specification
Signal level	IEEE-1284 Level 1 device
Connector	57-30360 Amphenol connector or equivalent

Reverse channel

Specification	Description
Transmission mode	IEEE-1284 Nibble mode, IEEE-1284 ECP mode
Adaptable connector	57-30360 Amphenol connector or equivalent
Synchronization	Refer to the IEEE-1284 specification
Handshaking	Refer to the IEEE-1284 specification
Signal level	IEEE-1284 Level 1 device
Data transmission timing	Refer to the IEEE-1284 specification

Control Panel

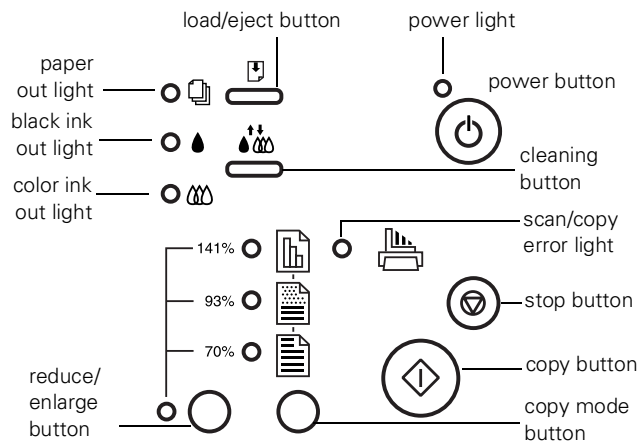

Follow these guidelines when the control panel lights come on or flash:



When the paper out light *flashes*, paper is jammed in the printer. Turn off the printer, remove all the paper (including any pieces torn off inside), then reload the stack. Turn on the printer and press the load/eject button.

When the paper out light *comes on*, your paper ran out or is incorrectly loaded. Load paper in the feeder and then press the load/eject button.



When an ink out light *flashes*, your ink supply is low. Make sure you have a replacement cartridge.

When an ink out light *comes on*, you need to replace the ink cartridge. See “Replacing an Ink Cartridge” on page 8 for instructions.



When the scan/copy error light *comes on*, a page or photo may be jammed in the scanner. Turn off the power, open the top cover, and remove the jammed document. Then close the cover and turn the power back on.



When the power and paper out lights *flash* and the black and color ink out lights *come on*, jammed paper may be blocking movement of the print head. Turn off the printer, open the front cover, and remove any paper. Then turn it back on.

When all the lights *flash*, your printer may have an internal error. Turn off the power and make sure you removed all the packing material. Make sure there is enough space around the rear vent. Then turn the power back on.

Installing an Ink Cartridge for the First Time

1. Plug the printer’s power cord into a grounded outlet.

Caution:

Don’t use an outlet that can be turned off by a wall switch or timer, or one on the same circuit as a large appliance. This may disrupt the power, which can erase the printer’s memory or damage its power supply.

2. Remove the ink cartridges from their packages. Then remove **only** the yellow part of the tape seal on top as shown.

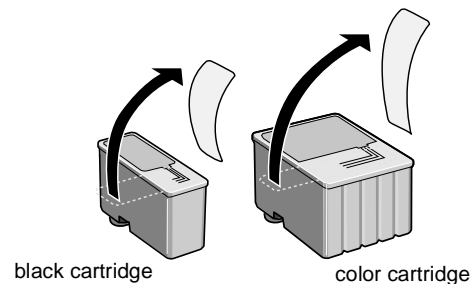

Caution:

Use the ink cartridges packed with your printer the first time you install them or your printer won’t charge ink properly. You must remove the yellow tape from the cartridge or you will permanently damage it. Don’t pull off the blue portion or try to remove the clear seal from the bottom of the cartridge; ink will leak out.

3. Lower the printer’s output tray and open the front cover.

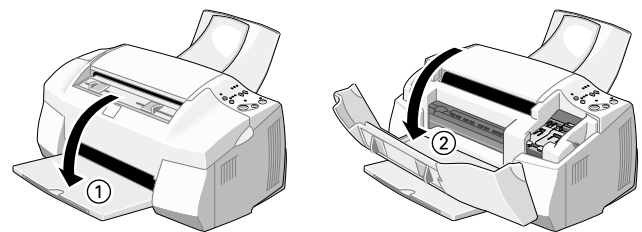

4. Press the power button to turn on the printer. The power light flashes and the black and color ink out lights come on. The print head moves.

Caution:

Always use the power button to turn the printer on or off. Never use an external switch, such as a power strip switch.

5. Lift up the color ink cartridge clamp.

- Place the color cartridge into its holder with the labels facing up and toward the back of the printer. Then press down the clamp until it locks into place.

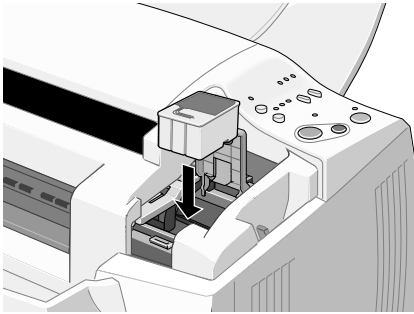

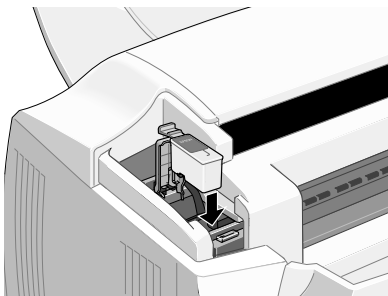

- Press the  cleaning button. The print head moves to the left so you can install the black ink cartridge.
- Lift up the black ink cartridge clamp.
- Place the black cartridge into its holder with the labels facing up and toward the back of the printer. Then press down the clamp until it locks into place.



WARNING:

If ink gets on your hands, wash them thoroughly with soap and water. If ink gets in your eyes, flush them immediately with water.

- Press the  cleaning button to begin charging the ink delivery system and close the front cover.

Charging takes about 2 minutes. The  power light flashes and the printer makes various sounds until it's finished. Don't turn off the printer or interrupt the charging process or it will start over, using more ink than necessary. Charging is finished when the  power light stops flashing and stays on.

Caution:

Never turn off the printer while the  power light is flashing, unless the printer hasn't moved or made any noise for more than 5 minutes.

Loading Paper

- Open the output tray and its extensions. Slide the edge guide out until it is a little wider than your paper.
- Load a stack of paper with the printable side up and place it against the right side of the feeder. Then slide the edge guide up against the paper's left edge. Don't load paper higher than the arrow on the guide.

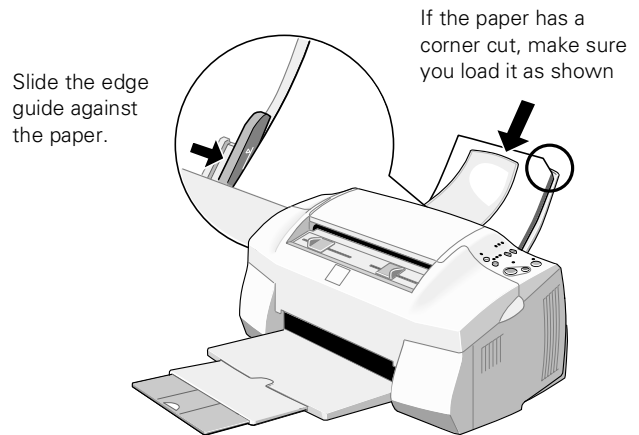





Testing the Printer

You can run a printer operation check to determine whether the problem comes from the printer or some other source.

- If the results are satisfactory, the problem lies in your software settings, the interface cable, or your computer.
 - If the check page does not print correctly, you have a problem with your printer. See the *User's Guide* for possible solutions.
- Make sure both the printer and computer are turned off.
 - Disconnect the interface cable from the printer.
 - Make sure paper is loaded in the printer.

Caution:

Load paper that's at least 8.27 inches (210 mm) wide. This prevents ink from spraying inside the printer and smudging your printouts.

- Hold down the  load/eject button and press the  power button. Hold down the  load/eject button until the  power light starts to flash, then release it.

The printer prints its ROM version number and a nozzle check pattern (shown in "Running a Nozzle Check" on page 10).

- To end the check, turn off the printer. Then reconnect the interface cable and turn on your printer and computer.

Using Special Media

Selecting Special Media

When you print on special media, you need to choose the correct **Media Type** and **Paper Size** settings in your printer software. The table below lists the available EPSON media and the corresponding **Media Type** setting for each one.

Media name	Media Type setting
EPSON 360 dpi Ink Jet Paper	360 dpi Ink Jet Paper
EPSON Iron-On Cool Peel Transfer Paper	
EPSON High Quality Ink Jet Paper	Photo Quality Ink Jet Paper
EPSON Photo Quality Ink Jet Paper	
EPSON Photo Quality Ink Jet Cards	
EPSON Photo Quality Self Adhesive Sheets	
EPSON Matte Paper	Matte Paper - Heavyweight
EPSON Photo Quality Glossy Paper	Photo Paper
EPSON Photo Paper	
EPSON Photo Quality Glossy Film	Photo Quality Glossy Film
EPSON Photo Stickers	
EPSON Ink Jet Transparencies	

Caution:

Don't use the cleaning sheets that may be included with your special media; they may jam inside the printer.



Media Loading and Handling Guidelines

- Always handle sheets by the edges, and don't touch the printable surface.
- When you load paper, make sure the printable side is facing up.
- You can load paper up to the arrow mark on the edge guide.
- Return unused sheets and envelopes to their original package as soon as possible. See "Paper" on page 2 for more storage information.
- If your paper package included protective sheets, cover the printed side of your paper with these sheets before stacking your paper.
- Use ink jet papers within one year of purchase. Use glossy media and transparencies within six months.

Copying without Your Computer

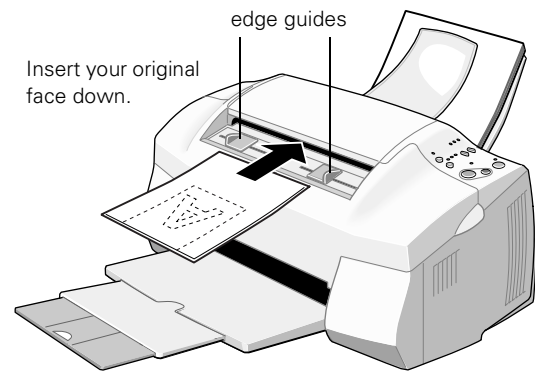

1. Adjust the edge guides to fit the width of your original.
2. Hold the document face down and insert the bottom edge into the scanner.



3. Make sure the edge guides touch the sides of your original, then feed it in until you feel a tug.
4. Release the document.
5. If you want a smaller or larger copy, press the **Reduce/Enlarge** button until the size you want is selected. The lights indicate the current size setting.
6. Press the **Copy Mode** button to select one of the following:
 -  Black and white text
 -  Black and white photo or image (grayscale)
 -  Color

The lights indicate the current mode setting.
7. Press the green **Copy** button. Your original goes into the scanner and then comes back out. As it comes out, the copy is printed.
8. Press the red **Stop/Clear** button to eject your original.

Replacing an Ink Cartridge

When the  black or  color ink out light flashes, the indicated cartridge is low on ink. This is a good time to make sure you have a new cartridge. When the light stays on, the cartridge is empty and you need to replace it.

Use these EPSON ink cartridges within six months of installing them and before the expiration date on the package:

Black ink cartridge: S020189

Color ink cartridge: S020191

Caution:

To ensure good results, use genuine EPSON cartridges and do not refill them. Other products may cause damage to your printer not covered by EPSON's warranty.

If you need to replace an ink cartridge **before** the lights flash (because the ink is too old, for example) follow the instructions in "Replacing an Outdated Ink Cartridge" on page 9.

Replacing the Color Ink Cartridge

You can replace a cartridge when the  color ink out light is either flashing or on.

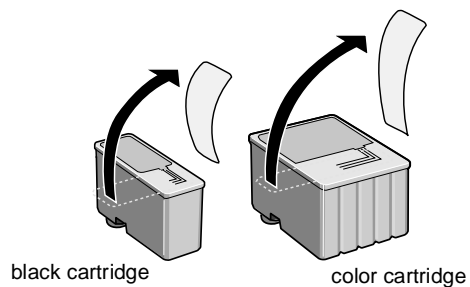

1. Remove the new ink cartridge from its packaging.
2. Remove **only** the yellow part of the tape seal on top as shown below.



Caution:

You must remove the yellow tape from the top of the cartridge or you will permanently damage it. Don't pull off the blue portion or remove the clear seal from the bottom of the cartridge; ink will leak out.

To avoid damaging the printer, never move the print head by hand.

3. Lower the output tray, then open the front cover.
4. Press the  cleaning button and hold it for about three seconds until the print head moves left and the  power light begins flashing.

5. Pull up the ink cartridge clamp. The cartridge rises up from its holder.

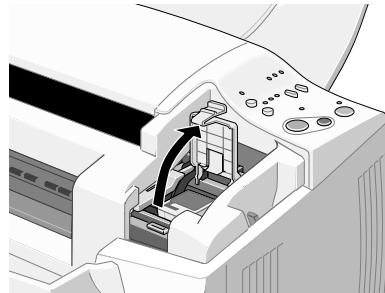

Caution:

Don't open the clamp or remove a cartridge except to replace it with a new one. Once you remove a cartridge, you can't reuse it, even if it contains ink.

6. Lift the cartridge out of the printer and dispose of it carefully.

WARNING:

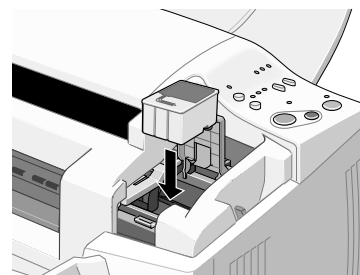

If ink gets on your hands, wash them thoroughly with soap and water. If ink gets into your eyes, flush them immediately with water.

7. Lower the new ink cartridge into its holder with the label facing up and toward the back of the printer.
8. Press down the ink cartridge clamp until it locks in place.



9. Press the  cleaning button and release it quickly.

The printer moves the print head and begins charging the ink delivery system. (Even if you don't press the button, ink charging begins 60 seconds after you close the clamp.)

The  power light flashes, and the printer makes various sounds. Charging takes about 60 seconds. When it's finished, the  power light stops flashing and stays on.

Caution:

Never turn off the printer while the  power light is flashing, unless the printer hasn't moved or made any noise for more than 5 minutes.

10. Close the front cover.

Replacing the Black Ink Cartridge

You can replace a cartridge when the  black ink out light is flashing, or when it stays on.

1. Follow steps 1 through 4 on page 8.

Caution:

Don't open the clamp or remove a cartridge except to replace it with a new one. Once you remove a cartridge, you can't reuse it, even if it contains ink.

2. Pull up the black ink cartridge clamp. The cartridge rises up from its holder.

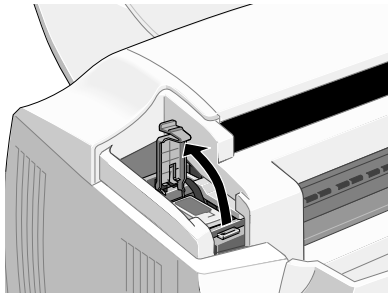

WARNING:

If ink gets on your hands, wash them thoroughly with soap and water. If ink gets into your eyes, flush them immediately with water. Keep ink cartridges out of the reach of children.

3. Lift the cartridge out of the printer and dispose of it carefully.
4. Lower the new ink cartridge into its holder with the label facing up and toward the back of the printer. Don't press down on the cartridge.

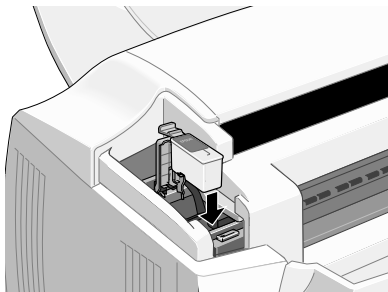



5. Press down the ink cartridge clamp until it locks in place. Then press the  cleaning button and release it quickly.

Caution:

Never turn off the printer while the  power light is flashing, unless the printer hasn't moved or made any noise for more than 5 minutes.



The printer moves the print head and begins charging the ink delivery system. (Even if you don't press the button, ink charging begins 60 seconds after you close the clamp.)



The  power light flashes and the printer makes various sounds. Charging takes about 60 seconds. When it's finished, the  power light stops flashing and stays on.

6. Close the front cover.

Replacing an Outdated Ink Cartridge



If an ink cartridge is more than six months old, you may need to replace it, especially if your printouts don't look as good as they used to. If print quality doesn't improve after cleaning and aligning the print head, you can replace one or both cartridges.



Follow these steps to replace an ink cartridge **before** the  black or  color ink out light is flashing or on:

1. Prepare your new ink cartridge for installation as described in steps 1 and 2 of "Replacing the Color Ink Cartridge" on page 8.
2. Make sure the printer is turned on and not printing, then lower the output tray and open the front cover.
3. Press the  load/eject button and hold it down for three seconds until the print head moves to the color cartridge replacement position. The  power light begins flashing.

Caution:

To avoid damaging the printer, never move the print head by hand. Never turn off the printer while the  power light is flashing, unless the printer hasn't moved or made any noise for more than 5 minutes.

4. If you need to replace the color ink cartridge, go on to step 5 below. If you need to replace the black cartridge only, press the  load/eject button again and release it quickly to move the print head to the black cartridge replacement position.
5. Remove the old ink cartridge and install the new cartridge as described on page 8. Don't press the  cleaning button, however.
6. Press the  load/eject button and release it quickly.

The printer moves the print head and begins charging the ink delivery system. The  power light flashes and the printer makes various sounds. Charging takes about a minute. When it's finished, the  power light stops flashing and stays on.





Cleaning the Print Head

If your printed image is unexpectedly light or faint, or dots are missing from the image, you may need to clean the print head. This unclogs the nozzles so they can deliver ink properly.

Cleaning the print head uses ink, so clean it only if print quality declines. You can clean the print head in either of the following ways:

- With the Head Cleaning utility (when connected to a local port, not over a network)
- Using the printer's control panel buttons

Using the Head Cleaning Utility

1. Make sure the printer is turned on but not printing, and the  black and  color ink out lights are off.
2. Do one of the following:
 - (Windows) Click **Start**, point to **Settings**, then select **Printers**. Right-click the **EPSON Stylus Scan 2000** icon and select **Properties**. Click the **Utility** tab.
 - (Macintosh) Open the **File** menu and choose **Page Setup** or **Print**. Then click the  **Utility** icon.
3. Click the **Head Cleaning** icon.
4. Follow the instructions on the screen to clean the print head. Cleaning takes about a minute, during which the printer makes some noise and the  power light flashes.





When the  power light stops flashing, continue with the next step.

Caution:
Never turn off the printer while the  power light is flashing, unless the printer hasn't moved or made any noise for more than 5 minutes.

5. Make sure paper is loaded and click **Print nozzle check pattern** (Windows) or **Confirmation** (Macintosh). Then click **Next**. The nozzle check pattern prints; see "Running a Nozzle Check" on page 10 for details.

Using the Control Panel

Follow these steps to clean the print head:



1. Make sure the printer is turned on and not printing, and that the  black and  color ink out lights are off.
2. Press the  cleaning button and hold it down for three seconds. Cleaning takes about a minute, during which the printer makes some noise and the  power light flashes.

Caution:

Never turn off the printer while the  power light is flashing, unless the printer hasn't moved or made any noise for more than 5 minutes.

3. After the  power light stops flashing, print a page to test the print quality and reset the cleaning cycle.
4. Run a **Nozzle Check**, examine the check pattern, and respond as described below.

Running a Nozzle Check

1. Make sure the printer is turned on but not printing, and the  black and  color ink out lights are off.
2. Do one of the following:
 - (Windows) Click **Start**, point to **Settings**, then select **Printers**. Right-click the **EPSON Stylus Scan 2000** icon and select **Properties**. Click the **Utility** tab.
 - (Macintosh) Open the **File** menu and choose **Page Setup** or **Print**. Then click the  **Utility** icon.
3. Click the **Nozzle Check** icon on the Utility menu.
4. Follow the instructions on the screen to run the **Nozzle Check**.
5. Examine the nozzle check pattern you print. It should look something like this, with the lower pattern colored magenta, cyan, and yellow:

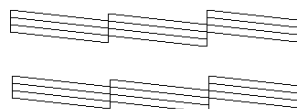

Each staggered horizontal and straight vertical line should be complete, with no gaps in the dot pattern. If any dots are missing, as shown below, clean the print head again; see "Cleaning the Print Head" on page 10 for instructions.

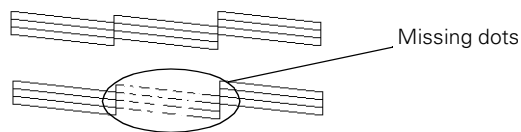

- If the nozzle check pattern is complete, click **Finish**.
- If the pattern is missing dots, click **Clean** to run another cleaning cycle.
- If you don't see any improvement after cleaning four or five times, turn the printer off, wait until the next day, and run the cleaning cycle again.
- If quality still doesn't improve, one or both of your ink cartridges may be old or damaged, and you may need to replace them. See page 8 for instructions.

Aligning the Print Head

If your printouts contain misaligned vertical lines, you may need to align the print head using the Print Head Alignment utility in your printer software. Your EPSON Stylus Scan must be connected to a local port, not on a network, to use this utility.

1. Make sure the printer is turned on and paper is loaded.

Caution:

Load paper that's at least 8.27 inches (210 mm) wide. This prevents ink from spraying inside the printer and smudging your printouts. For the best results, load EPSON ink jet paper in the printer whenever you check the print head alignment.

2. Do one of the following:
 - (Windows) Click **Start**, point to **Settings**, then select **Printers**. Right-click the **EPSON Stylus Scan 2000** icon and select **Properties**. Click the **Utility** tab.
 - (Macintosh) Open the **File** menu and choose **Page Setup** or **Print**. Then click the  **Utility** icon.
3. Click the **Print Head Alignment** icon on the Utility menu.
4. Follow the instructions on the screen to print a test page and select the correct alignment.

Cleaning the EPSON Stylus Scan

To keep your printer working at its best, you should clean it several times a year, following these steps:

1. Turn off the printer, unplug the power cord, and disconnect the printer cable.
2. Remove the paper.
3. Use a soft brush to clean loose dust and dirt.
4. Use a soft, clean cloth and mild detergent to clean the outer case and inside of the paper feeder. Be careful not to soak the cloth—just dampen it. Keep the front and top covers closed to prevent moisture from getting inside.
5. Open the top cover and clean the scanner glass with a soft, dry cloth, or with a blower brush.
6. If ink leaks inside the printer, wipe it away with a damp cloth.

Caution:

Don't touch the gears inside the printer.

Never use alcohol or thinner for cleaning; they can damage the printer components and case.

Don't use a hard or abrasive brush.

Don't get water on the printer components.

Don't spray lubricants or oils inside the printer.

Transporting the EPSON Stylus Scan

If you move your printer some distance, you need to prepare it for transportation in its original box. Follow these steps:

1. Press the  power button to turn the printer off. Then unplug the power cord and remove the interface cable.
2. Make sure the top cover is closed.
3. Remove all paper and then remove the paper and document supports.
4. Make sure the output tray is lowered, then open the front cover.
5. Secure the ink cartridge holder with tape, as shown.

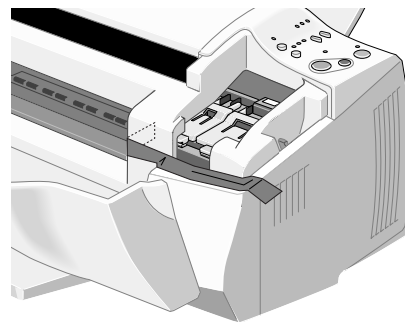

6. Close the cover and raise the tray.
7. Use the original box and packing materials to repack the printer.
8. Keep the EPSON Stylus Scan level during transport.

Scanning

1. Feed in your photo or document as described on page 7.
2. Use the Smart Panel and follow the instructions on the screen (Windows only). Or, follow the instructions below.
3. Open an application and select **Stylus Scan SF** as your TWAIN source.
4. If you're scanning a photograph, click the **Photo** tab. If you're scanning text or a line drawing, click the **OCR/Line Art** tab.
5. Choose **Draft & fast** for a quick scan or **Best & de-screening** for a better quality scan
6. Choose the Resolution setting.
7. Choose your Document Size.

Continue with the steps in one of the next sections: either "Scanning a Photo" or "Scanning Text or Line Art."

Scanning a Photo

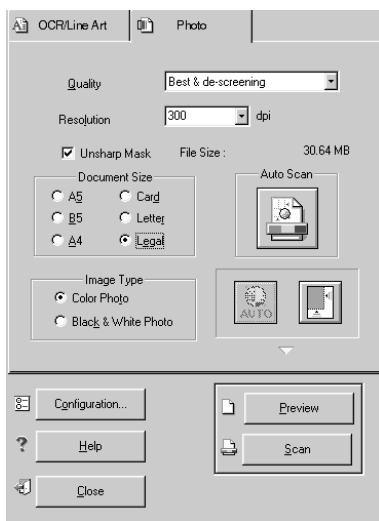

1. Select **Unsharp Mask** to sharpen your image automatically.
2. Choose your Image Type.
3. Do one of the following:
 - Click the **Auto Scan** button. Your photo or page goes in and out of the scanner twice. The TWAIN window closes, and your scanned image appears on your screen.
 - Click the **Preview** button. Your photo or page goes into the scanner and comes back out. The preview image appears on the right side of the TWAIN window. Continue with step 4.

4. If you want to crop the image, or scan only one section, click and drag on the preview image.
Or, click the **Auto Locate** button to automatically outline your photo and eliminate any white border around it.
5. Click the **Auto Exposure** button to automatically adjust scan settings for maximum enhancement of your photo.
6. Click the **Scan** button. Your photo or page goes into the scanner again and comes out slowly as it is scanned. Your image opens on your screen (behind the TWAIN window).
7. Click the **Close** button to close the TWAIN window.

Scanning Text or Line Art

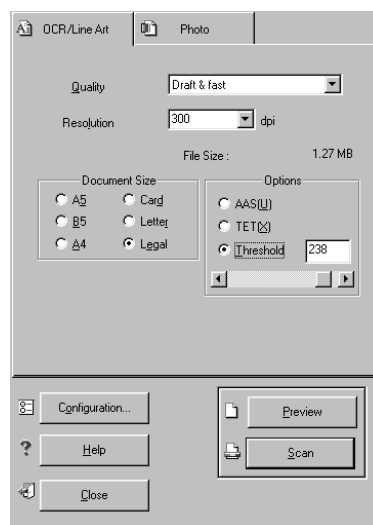

1. Click the **Preview** button. Your page goes into the scanner and comes back out. The preview image appears on the right side of the TWAIN window.
2. Select **AAS** (Auto Area Segmentation) or **TET** (Text Enhancement Technology). Or, select **Threshold** and move the slider to make your text lighter or darker.
3. When your preview looks good, click the **Scan** button. Your page goes into the scanner again and comes out slowly as it is scanned.

Related Documentation

TM-SCAN2000	EPSON Stylus Scan 2000 Service Manual
PL-SCAN2000	EPSON Stylus Scan 2000 Parts Price List
CPD-8877	EPSON Stylus Scan 2000 <i>User's Guide</i>
CPD-8878	EPSON Stylus Scan 2000 <i>Start Here</i> sheet