

User's Guide



Using Your Software

Introduction to the driver and application software that comes with your printer.



How to Print

Instructions for all types of printing.



Maintaining Your Printer

Instructions for maintaining, cleaning, and transporting your printer.



Problem Solver

Solutions to problems you may encounter.



Paper Handling

Instructions for loading paper and selecting paper types.



Replacing Ink Cartridges

How to check your ink cartridge status and replace cartridges.



Doing More with Your Printer

How to use your printer's special features.



Product Information

Detailed information about your printer's features and specifications.

- [Safety](#)
- [Copyright and Trademarks](#)
- [Operating System Versions](#)

[Home](#) > [Using Your Software](#)

Using Your Software

 [Printer Driver and Status Monitor](#)

 [Printing Photos the Easy Way](#)

 [Printing Web Pages to Fit to Your Paper Size](#)

 [Uninstalling the Printer Software](#)

[Home](#) > Paper Handling

Paper Handling

 [Using Special Paper](#)

 [Loading Paper](#)

 [Loading Envelopes](#)

 [Selecting the Correct Paper Type](#)

Home > How to Print

How to Print

Basic Printing

[Introduction](#)

[Printing Photos](#)

[Printing Documents](#)

[Printing Web Pages](#)

[Printing on Envelopes](#)

[Canceling Printing](#)

Printing with Special Layout Options

[Introduction](#)

[2-sided Printing \(Windows Only\)](#)

[Fit to Page Printing](#)

[Pages Per Sheet Printing](#)

[Poster Printing \(Windows Only\)](#)

[Watermark Printing \(Windows Only\)](#)

[Home](#) > [Replacing Ink Cartridges](#)

Replacing Ink Cartridges

[Checking the Ink Cartridge Status](#)

[Precautions on Ink Cartridge Replacement](#)

[Conserving Black Ink When the Cartridge Is Low \(Windows Only\)](#)

[Replacing an Expended Ink Cartridge](#)

[Replacing an Ink Cartridge Before it Is Expended](#)

[Home](#) > Maintaining Your Printer

Maintaining Your Printer

 [Checking the Print Head Nozzles](#)

 [Cleaning the Print Head](#)

 [Aligning the Print Head](#)

 [Cleaning the Paper Guide](#)

 [Cleaning Your Printer](#)

 [Transporting Your Printer](#)

[Home](#) > [Doing More with Your Printer](#)

Doing More with Your Printer

Sharing Your Printer

 [Setup for Windows](#)

 [Setup for Mac OS X](#)

Home > Problem solver

Problem solver

Technical support web site URL:

<http://www.latin.epson.com/>

Troubleshooting

 [Diagnosing the Problem](#)

 [Checking Printer Status](#)

 [Print Quality Problems](#)

 [Miscellaneous Printout Problems](#)

 [Paper Does not Feed Correctly](#)

 [The Printer Does Not Print](#)

 [Increasing the Print Speed \(Windows Only\)](#)

Where to Get Help

 [Technical Support Web Site](#)

 [Contacting Customer Support](#)

[Home](#) > [Product Information](#)

Product Information

 [Printer Parts and Control Panel Functions](#)





 [Ink and Paper](#)

 [System Requirements](#)

 [Technical Specifications](#)

[Home](#) > [Safety](#)

Important Safety Instructions

-  [Setting up the Printer](#)
-  [Choosing a Place for the Printer](#)
-  [Using the Printer](#)
-  [Handling Ink Cartridges](#)
-  [Warnings, Cautions, and Notes](#)

Read all of the instructions in this section before using the printer. Also, be sure to follow all warnings and instructions marked on the printer.

Setting up the Printer

Observe the following when setting up the printer:

- Do not block or cover the vents and openings in the printer.
- Use only the type of power source indicated on the printer's label.
- Use only the power cord that comes with the printer. Use of another cord may result in fire or electric shock.
- The printer's power cord is for use with the printer only. Use with other equipment may result in fire or electric shock.
- Be sure your AC power cord meets the relevant local safety standard.
- Avoid using outlets on the same circuit as photocopiers or air control systems that regularly switch on and off.
- Avoid electrical outlets controlled by wall switches or automatic timers.
- Keep the entire computer system away from potential sources of electromagnetic interference, such as loudspeakers or the base units of cordless telephones.
- Do not use a damaged or frayed power cord.
- If you use an extension cord with the printer, make sure that the total ampere rating of the devices plugged into the extension cord does not exceed the cord's ampere rating. Also, make sure that the total ampere rating of all devices plugged into the wall outlet does not exceed the wall outlet's ampere rating.
- Do not attempt to service the printer yourself.
- Unplug the printer and refer servicing to qualified service personnel under the following conditions: The power cord or plug is damaged; liquid has entered the printer; the printer has been dropped or the casing damaged; the printer does not operate normally or exhibits a distinct change in performance.
- When connecting the printer to a computer or other device with a cable, ensure the correct orientation of the connectors. Each connector has only one correct orientation. Inserting a connector in the wrong orientation may damage both devices connected by the cable.
- If damage occurs to the plug, replace the cord set or consult a qualified electrician. If there are fuses in the plug, make sure you replace them with fuses of the correct size and rating.

[Top](#) 

Choosing a Place for the Printer



Observe the following when choosing a place for the printer:

- Place the printer on a flat, stable surface that extends beyond the base of the printer in all directions. If you place the printer by the wall, leave more than 10 cm between the back of the printer and the wall. The printer will not operate properly if it is tilted at an angle.
- When storing or transporting the printer, do not tilt it, stand it on its side, or turn it upside down. Otherwise, ink may leak from the cartridges.
- Leave enough space in front of the printer for the paper to be fully ejected.
- Avoid places subject to rapid changes in temperature and humidity. Also, keep the printer away from direct sunlight, strong light, or heat sources.
- Avoid places subject to dust, shocks, or vibrations.
- Leave enough room around the printer to allow for sufficient ventilation.
- Place the printer near a wall outlet where the plug can be easily unplugged.

[Top](#) 

Using the Printer

Observe the following when using the printer:

- Do not insert objects through the slots in the printer.
- Take care not to spill liquid on the printer.
- Do not put your hand inside the printer or touch the ink cartridges during printing.
- Do not touch the white flat cable inside the printer.
- Do not use aerosol products that contain flammable gases inside or around this printer. Doing so may cause fire.
- Do not move the print head by hand; otherwise, you may damage the printer.
- Always turn the printer off using the  power button. When this button is pressed, the  power light flashes. Do not unplug the printer or turn off the power to the outlet until the  power light stops flashing.
- Before transporting the printer, make sure that the print head is in the home (far right) position and the ink cartridges are in place.
- Leave the ink cartridges installed. Removing the cartridges can dehydrate the print head and may prevent the printer from printing.

[Top](#) 

Handling Ink Cartridges

Observe the following when handling the ink cartridges:

- Keep ink cartridges out of the reach of children. Do not allow children to drink from or handle the cartridges.
- Shake new ink cartridges four or five times before opening their packages.
- Do not shake ink cartridges after opening their packages; this can cause leakage.
- Be careful when you handle used ink cartridges, as there may be some ink remaining around the ink supply port. If ink gets on your skin, wash the area thoroughly with soap and water. If ink gets into your eyes, flush them immediately with water. If discomfort or vision problems remain after a thorough flushing, see a doctor immediately.
- Do not remove or tear the label on the cartridge; this can cause leakage.
- Install the ink cartridge immediately after you remove it from its package. If you leave a cartridge unpacked for a long time before using it, normal printing may not be possible.
- Use the ink cartridge before the date printed on its package.
- Do not disassemble or remodel the ink cartridge, otherwise you may not be able to print normally.

- After bringing an ink cartridge inside from a cold storage site, allow it to warm up at room temperature for at least three hours before using it.
- Store ink cartridges in a cool, dark place.
- Do not touch the green IC chip on the side of the cartridge. Doing so may prevent normal operation and printing.
- If you remove an ink cartridge for later use, protect the ink supply area from dirt and dust, and store it in the same environment as the printer. A valve in the ink supply port makes covers or plugs unnecessary, but the ink may stain items that come into contact with this area of the cartridge. Do not touch the ink supply port or the surrounding area.
- Store ink cartridges with their labels facing upward. Do not store cartridges upside down.

[Top](#) 

Warnings, Cautions, and Notes

Warnings, Cautions, and Notes in this User's Guide are indicated as below and have the following meaning.

Warnings

must be followed carefully to avoid bodily injury.

Cautions

must be observed to avoid damage to your equipment.

Notes

contain important information and useful tips on the operation of the printer.

[Home](#) > Copyright and Trademarks

■ Copyright and Trademarks

No part of this publication may be reproduced, stored in a retrieval system, or transmitted in any form or by any means, electronic, mechanical, photocopying, recording, or otherwise, without the prior written permission of Seiko Epson Corporation. The information contained herein is designed only for use with this Epson printer. Epson is not responsible for any use of this information as applied to other printers.

Neither Seiko Epson Corporation nor its affiliates shall be liable to the purchaser of this product or third parties for damages, losses, costs, or expenses incurred by the purchaser or third parties as a result of accident, misuse, or abuse of this product or unauthorized modifications, repairs, or alterations to this product, or (excluding the U.S.) failure to strictly comply with Seiko Epson Corporation's operating and maintenance instructions.

Seiko Epson Corporation shall not be liable for any damages or problems arising from the use of any options or any consumable products other than those designated as Original Epson Products or Epson Approved Products by Seiko Epson Corporation.

Seiko Epson Corporation shall not be held liable for any damage resulting from electromagnetic interference that occurs from the use of any interface cables other than those designated as Epson Approved Products by Seiko Epson Corporation.

Epson® and Epson Stylus® are registered trademarks, and Epson Exceed Your Vision is a registered logomark of Seiko Epson Corporation.

PRINT Image Matching™ and the PRINT Image Matching logo are trademarks of Seiko Epson Corporation. Copyright © 2001 Seiko Epson Corporation. All rights reserved.

Microsoft®, Windows®, and Windows Vista® are registered trademarks of Microsoft Corporation.

Apple® and Macintosh® are registered trademarks of Apple Inc.

Intel® is a registered trademark of Intel Corporation.

PowerPC® is a registered trademark of International Business Machines Corporation.

General Notice: Other product names used herein are for identification purposes only and may be trademarks of their respective owners. Epson disclaims any and all rights in those marks.

Copyright © 2009 Seiko Epson Corporation. All rights reserved.



[Home](#)



[Contents](#)



[Index](#)



[Help](#)

[Home](#) > Operating System Versions

■ Operating System Versions

In this manual, the following abbreviations are used.

Windows refers to Windows Vista, XP, and 2000.

- Windows Vista refers to Windows Vista Home Basic Edition, Windows Vista Home Premium Edition, Windows Vista Business Edition, Windows Vista Enterprise Edition, and Windows Vista Ultimate Edition.
- Windows XP refers to Windows XP Home Edition, Windows XP Professional x64 Edition, and Windows XP Professional.
- Windows 2000 refers to Windows 2000 Professional.

Macintosh refers to Mac OS X.

- Mac OS X refers to Mac OS X 10.3.9, 10.4.x - 10.5.x.







[Home](#) > [Help](#)

User's Guide Help

Finding your way around

This *User's Guide* includes links to make moving between sections easier. Links appear as colored, underlined text. When you place your cursor over a link, it changes to a hand icon. Click the link to access a related topic or detailed information.

You can also click these links to move around the *User's Guide*:

 Home	Returns to the opening page.
 Contents	Opens the Table of Contents. You can close the window by clicking the  Close button.
 Index	Opens the Index. You can close the window by clicking the  Close button.
 Search	Opens the Search window, where you can locate topics by entering keywords.
 Top	Returns to the top of the current page.

Printing a Topic

To print the page you are currently on, open the **File** menu and click **Print** in your browser.

Solving Display Problems

If a page in the *User's Guide* displays incorrectly, click the **Refresh** or **Reload** button in your browser.

[Home](#) > [Using Your Software](#)

Printer Driver and Status Monitor

 [Accessing the Printer Driver for Windows](#)

 [Accessing the Printer Driver for Mac OS X](#)

The printer driver lets you choose from a wide variety of settings to get the best printing results. Status Monitor and the printer utilities help you check the printer and keep it in top operating condition.

Note for Windows users:

- Your printer driver automatically finds and installs the latest version of the printer driver from Epson's web site. Click the **Driver Update** button in your printer driver's **Maintenance** tab, and then follow the on-screen instructions. If the button does not appear in the **Maintenance** tab, point to **All Programs** or **Programs** in the Windows Start menu, and check in the **Epson** folder.
- If you want to change the language of the driver to Spanish or Portuguese, select the language you want to use from the **Language** setting in your printer driver's **Maintenance** tab.

Accessing the Printer Driver for Windows

You can access the printer driver from most Windows applications, the Windows Start menu, or the taskbar.

To make settings that apply only to the application you are using, access the printer driver from that application.

To make settings that apply to all of your Windows applications, access the printer driver from the Start menu or the taskbar.

Refer to the following sections to access the printer driver.

Note:

Screen shots of the printer driver windows in this *User's Guide* are from Windows Vista.

From Windows applications

- 1 Click **Print** or **Print Setup** on the File menu.
- 2 In the window that appears, click **Printer**, **Setup**, **Options**, **Preferences**, or **Properties**. (Depending on your application, you may need to click one or a combination of these buttons.)

From the Start menu

Windows Vista:



Click the  button, select **Control Panel**, and then select **Printer** from the **Hardware and Sound** category. Then select the printer and then select **Printing Preferences**.

Windows XP:

Click **Start**, **Control Panel**, **Printers and Other Hardware**, then **Printers and Faxes**. Select the printer, then click **Printing Preferences** in the File menu.

Windows 2000:

Click **Start**, point to **Settings**, then click **Printers**. Select the printer, then click **Printing Preferences** in the File menu.

From the shortcut icon on the taskbar

Right-click the printer icon on the taskbar, then select **Printer Settings**.

To add a shortcut icon to the Windows taskbar, first access the printer driver from the Start menu as described above. Next, click the **Maintenance** tab, the **Speed & Progress** button, and then the **Monitoring Preferences** button. In the Monitoring Preferences window, select the **Select Shortcut Icon** check box.

Getting information through online help

You can access online help for items in the printer driver from your application or the Windows Start menu.



[Accessing the Printer Driver for Windows](#)

In the printer driver window, try one of the following procedures.

- Right-click the item, then click **Help**.
- Click the  button at the top right of the window, then click the item (for Windows XP and 2000 only).

[Top](#) 

Accessing the Printer Driver for Mac OS X

The table below describes how to access the printer driver dialog boxes.

Dialog Box	How to Access It
Page Setup	Click Page Setup on the File menu of your application.  Note for Mac OS X 10.5.x: <div style="border: 1px solid gray; padding: 5px; background-color: #e0e0e0;"> Depending on your application, the Page Setup menu may not appear in the File menu. </div>
Print	Click Print in the File menu of your application.

EPSON Printer
Utility3

You can access this software in the following three ways:

- Double-click the **EPSON Printer Utility3** icon in the Applications folder in Macintosh HD. Select the printer from the Printer List, then click **OK**.
- Click **Print** from your application's File menu, choose **Print Settings** in the Print window that is displayed, then click the  Utility icon. This Utility icon is not displayed when the printer is shared.
- For Mac OS X 10.3.9 - 10.4.x only
Open the **Applications** folder on your hard drive, then open the **Utilities** folder and double-click the **Print Center** or **Printer Setup Utility** icon. Select the appropriate printer from the list, then click the **Configure** or **Utility** button.



[Home](#) > [Using your software](#)

■ Printing Photos the Easy Way

 [Starting Epson Easy Photo Print](#)



Epson Easy Photo Print lets you lay out and print digital images on various types of paper. The step-by-step instructions in the window let you preview the printed images and get the effects you want without having to make any difficult settings.

Using the Quick Print function, you can perform one-click printing with the settings you make.

Starting Epson Easy Photo Print

- Double-click the **Epson Easy Photo Print** icon on the desktop.

- **For Windows Vista:**

Click the  button, point to **All Programs**, click **Epson Software**, and then click **Easy Photo Print**.

- **For Windows XP and 2000:**

Click **Start**, point to **All Programs** (Windows XP) or **Programs** (Windows 2000), point to **Epson Software**, then click **Easy Photo Print**.

For more information, select *User's Guide* from the Help menu in this application.

[Home](#) > [Using your software](#)

■ Printing Web Pages to Fit to Your Paper Size

 [Accessing EPSON Web-To-Page](#)



EPSON Web-To-Page lets you make web pages fit to your paper size when printing. You can also see a preview before printing.

 **Note:**

- This software is not available for Windows Vista, XP x64 or Mac OS X.
- This software is compatible only with Internet Explorer 5.x to 6.x.

 **Note for Windows Internet Explorer 7 users:**

Printing web pages to fit to your paper size is a standard feature in Windows Internet Explorer 7.

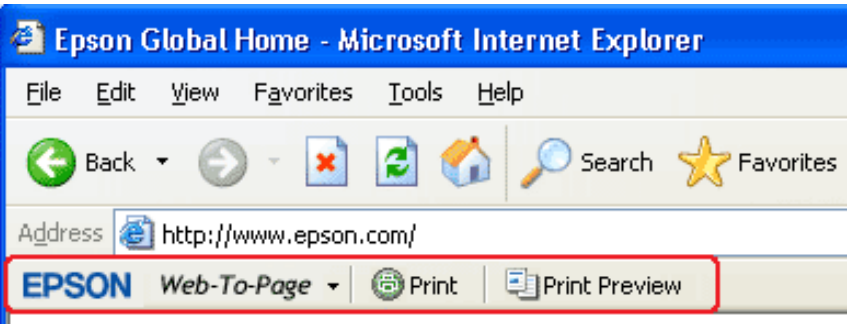

Accessing EPSON Web-To-Page

After you install EPSON Web-To-Page, the menu bar is displayed on the Microsoft Internet Explorer Toolbar. If it does not appear, select **Toolbars** from the View menu of Internet Explorer, and then select **EPSON Web-To-Page**.



[Home](#) > [Using Your Software](#)

■ Uninstalling the Printer Software

-  [Uninstalling the Printer Driver](#)
-  [Uninstalling the *User's Guide*](#)
-  [Uninstalling Other Epson Applications](#)

Uninstalling the Printer Driver

You may need to uninstall your printer driver if you:

- Upgrade your computer's operating system.
- Update your printer driver with a newer version except when updating through your printer driver's update function; the function uninstalls the older version automatically.
- Have a problem with the printer driver.

If you are upgrading your operating system or updating the printer driver version, be sure to uninstall the current printer driver *before* upgrading or installing the new driver. Otherwise, the driver update will not work.

For Windows users

Note:

- To uninstall programs in Windows Vista, you need an administrator account and the password if you log on as a standard user.
- To uninstall programs in Windows XP, you must log on to a Computer Administrator account.
- To uninstall programs in Windows 2000, you must log on as a user with administrative privileges (belonging to the Administrators group).

- 1** Turn off the printer and disconnect the USB cable.

2 Windows Vista:

Click the  button and select **Control Panel**.

Windows XP:

Click **Start**, then select **Control Panel**.

Windows 2000:

Click **Start**, point to **Settings**, and select **Control Panel**.

3 Windows Vista:

Click **Uninstall a program** from the **Programs** category, and then select **EPSON Stylus T21 Series Printer Uninstall** from the list.

Windows XP and 2000:

Double-click the **Add or Remove Programs** icon and select **EPSON Stylus T21 Series Printer Uninstall** from the list.

4 Windows Vista:

Click **Uninstall/Change**, then click **Continue** in the User Account Control window.

Windows XP and 2000:

Click **Change/Remove**.

5 Select the icon for your printer and click **OK**.

6 Click **OK** to uninstall the printer driver.

For Mac OS X

 **Note:**

To uninstall the programs, you must log on to a Computer Administrator account. You cannot uninstall programs if you log on as a Limited account user. Depending on the application, the Installer may be separated from the Uninstaller.

1 Quit all running applications.

2 Insert the Epson printer software CD-ROM into your Macintosh.

3 Double-click the **Epson** icon in the CD window.

 **Note:**

If the Authenticate dialog box appears, enter your password or phrase and click **OK**.

- 4 Select **English** at the language selection screen.
- 5 The Custom Installation screen appears. Deselect all items except **Epson Stylus T21 Driver**, then click **Install**.

 **Note:**

If the Authenticate dialog box appears, enter your password or phrase and click **OK**.

- 6 At the Installer screen, select **Uninstall** in the pop-up menu, then **Uninstall**.
- 7 Follow the on-screen instructions to uninstall the printer driver.
- 8 Click **Quit** to close the installation program.

 **Note for Mac OS X 10.3.9 to 10.4.x:**

If the name of your printer remains in the Print Center or Printer Setup Utility, select the name from Printer List and click **Delete**.

[Top](#) 

Uninstalling the Epson *User's Guide*

For Windows users

 **Note:**

- To uninstall programs in Windows Vista, you need an administrator account and the password if you log on as a standard user.
- To uninstall applications in Windows XP, you must log on to a Computer Administrator account. You cannot uninstall applications if you log on as a Limited user.
- To uninstall applications in Windows 2000, you must log on as a user with administrative privileges (belonging to the Administrators group).

- 1 Turn off the printer and disconnect its USB cable.

2 Windows Vista:

Click the  button and select **Control Panel**.

Windows XP:

Click **Start**, then select **Control Panel**.

Windows 2000:

Click **Start**, point to **Settings**, and select **Control Panel**. Click the start button and select **Control Panel**.

3 Windows Vista:

Click **Uninstall a program** from the Programs category, then select **Epson Stylus T21 Series User's Guide** from the list.

Windows XP and 2000:

Double-click the **Add or Remove Programs** icon and select **Epson Stylus T21 Series User's Guide** from the list.

4 Windows Vista:

Click **Uninstall/Change**, then click **Continue** in the User Account Control window.

Windows XP and 2000:

Click **Change/Remove**.

5 Click **OK**.

For Mac OS X



Note:

To uninstall the programs, you must log on to a Computer Administrator account. You cannot uninstall programs if you log on as a Limited account user.

1 Quit all running applications.

2 Open the **Applications** folder, then open the **Epson** folder.

3 Drag the **guide** folder to the Trash.

Top 

Uninstalling Other Epson Applications

You can uninstall applications you do not need. Follow the steps below.

For Windows users



Note:

- To uninstall programs in Windows Vista, you need an administrator account and the password if you log on as a standard user.
- To uninstall applications in Windows XP, you must log on to a Computer Administrator account. You cannot uninstall applications if you log on as a Limited user.
- To uninstall applications in Windows 2000, you must log on as a user with administrative privileges (belonging to the Administrators group).

1 Windows Vista:

Click the  button and select **Control Panel**.

Windows XP:

Click **Start**, then select **Control Panel**.

Windows 2000:

Click **Start**, point to **Settings**, and select **Control Panel**. Click the start button and select **Control Panel**.

2 Windows Vista:

Click the **Uninstall a program** from the Programs category.

Windows XP and 2000:

Double-click the **Add or Remove Programs** icon.

3 Choose the software you want to uninstall from the list of programs.

4 Windows Vista:

Click the **Uninstall/Change**, then click **Continue** in the User Account Control window.

Windows XP and 2000:

Click **Change/Remove**.

5 When the confirmation message appears, click **Yes**.

6 Follow the on-screen instructions.

For Mac OS X



- To uninstall applications, you must log on to a Computer Administrator account. You cannot uninstall applications if you log on as a Limited account user.
- Depending on the application, the Installer may be separated from the Uninstaller.

- 1 Quit all running applications.
- 2 Insert the Epson printer software CD-ROM into your Mac.
- 3 Double-click the **Epson** icon in the CD window.

 **Note:**

If the Authenticate dialog box appears, enter your password or phrase and click **OK**.

- 4 Select **English** at the language selection screen.
- 5 The Custom Installation screen appears. Deselect all items except **Epson Easy Photo Print**, then click **Install**.

 **Note:**

If the Authenticate dialog box appears, enter your password or phrase and click **OK**.

- 6 At the Installer screen, select **Uninstall** in the pop-up menu, then click **Uninstall**.
- 7 Follow the on-screen instructions to uninstall the application.
- 8 Click **Quit** to close the installation program.

 **Note:**

If you cannot select **Uninstall** in step 6, double-click the **Applications** folder in your Mac OS X hard drive, select the application you want to uninstall, and then drag it to the **Trash** icon.

[Home](#) > [Paper Handling](#)

Using Special Paper

[Loading Capacities for Epson Special Media](#)

[Storing Epson Photo Paper](#)

You can achieve good results with most types of plain bond paper. However, coated papers provide superior printouts because they absorb less ink.

Epson provides special papers that are formulated for the ink used in Epson ink jet printers, and recommends these papers to ensure high-quality results.

 [Paper](#)

When loading special paper distributed by Epson, read the instruction sheets packed with the paper first and keep the following points in mind.

Note:

- Load the paper into the sheet feeder printable side up. The printable side is usually whiter or glossier. See the instruction sheets packed with the paper for more information. Some types of paper have cut corners to help identify the correct loading direction.
- If the paper is curled, flatten it or curl it slightly in the opposite direction before loading. Printing on curled paper may cause ink to smear on your printout.



Loading Capacities for Epson Special Media

Refer to the table below for the loading capacities of Epson special paper and other media.

Media Type	Loading Capacity
Epson High Quality Ink Jet Plain Paper	Up to 80 sheets
Epson Bright White Paper	Up to 60 sheets
Epson Photo Paper Glossy	Up to 20 sheets
Epson Premium Photo Paper Glossy	Up to 10 sheets for 5 × 7 in. (13 × 18 cm) and 16:9 wide size (102 × 181 mm) Up to 20 sheets for all other sizes

Epson Premium Photo Paper Semi-gloss	Up to 20 sheets
Epson Ultra Premium Photo Paper Glossy	Up to 20 sheets
Epson Premium Presentation Paper Matte	1 sheet

 **Note:**

The availability of paper varies by location.

[Top](#) 

Storing Epson Photo Paper

Return unused paper to the original package as soon as you finish printing. Epson recommends storing your printouts in a resealable plastic bag. Keep them away from high temperature, humidity, and direct sunlight.

[Home](#) > [Paper Handling](#)

■ Loading Paper

Follow these steps to load paper:

- 1 Slide the edge guide to the left.

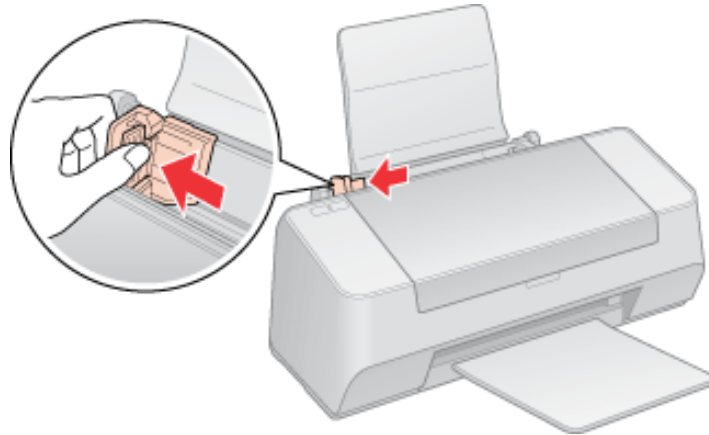

- 2 Fan a stack of paper, then tap it on a flat surface to even the edges.
- 3 Load the paper with the printable side up, against the right side of the sheet feeder. The printable side is often whiter or brighter than the other side.

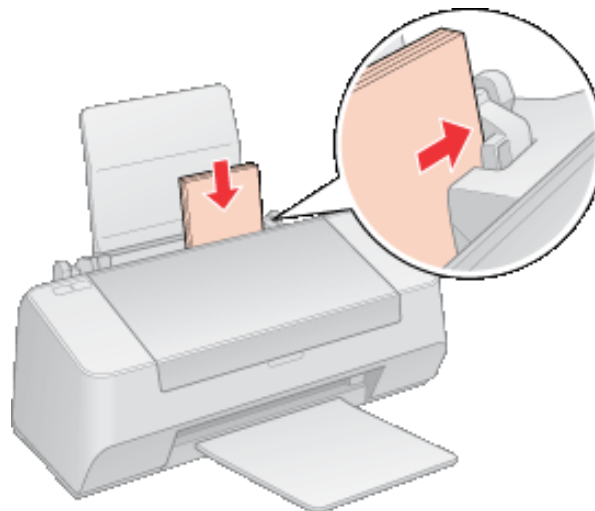

- 4 Slide the edge guide against the left edge of the paper, but not too tightly.

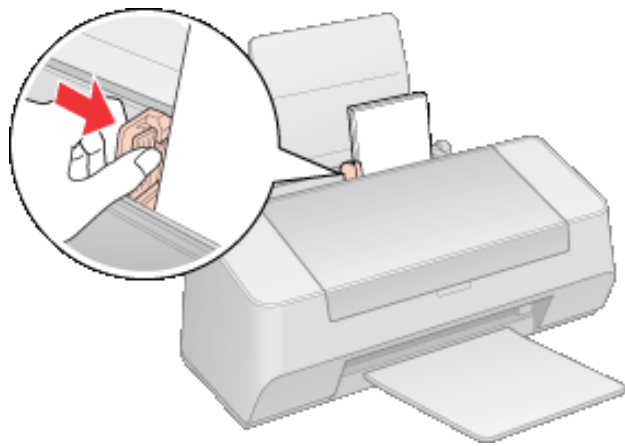

 **Note:**

- - Leave enough space in front of the printer for the paper to be fully ejected.
- - Always load paper into the sheet feeder short edge first, even when you are printing landscape-oriented pictures.
- - Make sure the paper stack fits under the  arrow mark inside the edge guide.

[Home](#) > [Paper Handling](#)

■ Loading Envelopes

Follow these steps to load envelopes:

- 1 Slide the edge guide to the left.

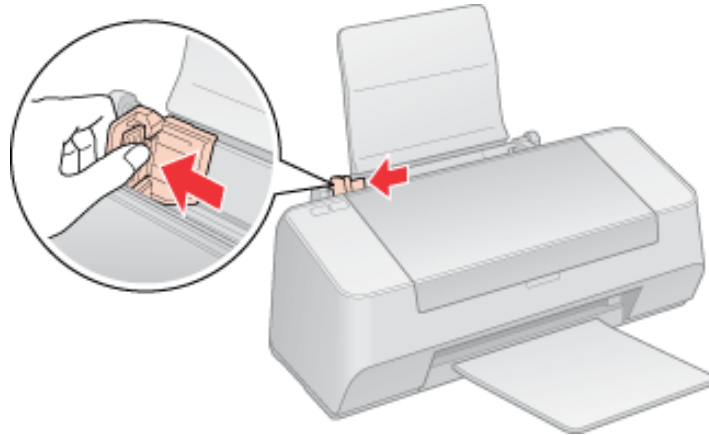

- 2 Load envelopes short edge first with the flap facing down and to the left. Then slide the edge guide against the left edge of the envelopes, but not too tightly.

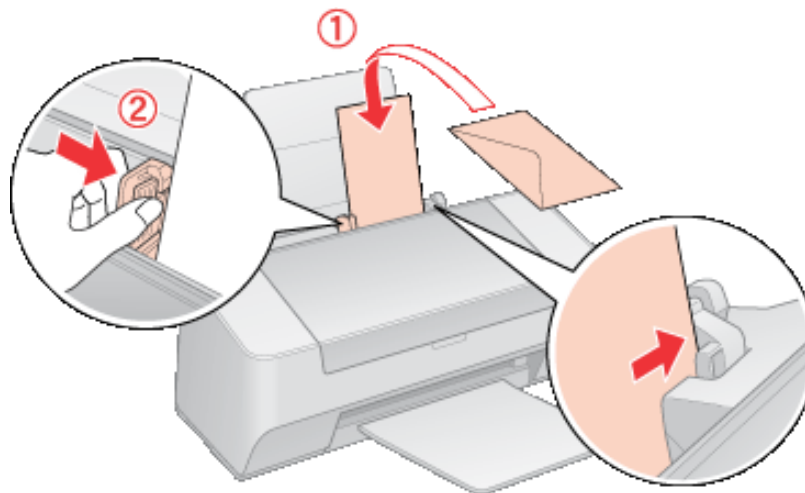

 **Note:**

- - The thickness of envelopes and their ability to fold vary widely. If the total thickness of the stack of envelopes exceeds 10 mm, press down on the envelopes to flatten them before loading. If print quality declines when a stack of envelopes is loaded, load one envelope at a time.
- - You can load up to 10 envelopes at a time in the sheet feeder.
- - Do not use envelopes that are curled or folded.
- - Press each envelope flat before loading it or load one envelope at a time.
- - Avoid using envelopes that are too thin, as they may curl during printing.

For printing instructions, see the following instructions.

 [Printing on Envelopes](#)

[Home](#) > [Paper Handling](#)

■ Selecting the Correct Paper Type

The printer automatically adjusts itself for the type of paper you select in your print settings. That is why the paper type setting is so important. It tells your printer what kind of paper you are using and adjusts the ink coverage accordingly. The table below lists the settings you should choose for your paper.

For this paper	Select this paper type setting
Plain paper*, Single sheets	Plain paper / Bright White Paper
Epson Bright White Paper*	
Epson Ultra Premium Photo Paper Glossy*	Ultra Premium Photo Paper Glossy
Epson Premium Photo Paper Glossy*	Premium Photo Paper Glossy
Epson Photo Paper Glossy*	Photo Paper Glossy
Epson Premium Photo Paper Semi-gloss*	Premium Photo Paper Semi-gloss
Epson Premium Presentation Paper Matte*	Premium Presentation Paper Matte
Envelopes	Envelope

* These paper types are compatible with Exif Print and PRINT Image Matching. For more information, refer to the documentation that came with the Exif Print or PRINT Image Matching compatible digital camera.

 **Note:**

The availability of special media varies by location. For the latest information on media available in your area, contact Epson customer support.

 See [Contacting Technical Support](#)

[Home](#) > [How to Print](#)

■ Introduction

- [Printing Photos](#)
- [Printing Documents](#)
- [Printing Web Pages](#)
- [Printing on Envelopes](#)

This section guides you through the procedures for different kinds of printing.

Printing photos

Explains how to print photos on various types of paper.

- [See Printing Photos](#)



[Top](#)

Printing Documents

Explains how to print documents on various types of paper.

- [See Printing Documents](#)



[Top](#)

Printing Web Pages

Explains how to print Web pages so that they fit on a sheet of paper without getting cut off on the right side.

[See Printing Web Pages](#)



[Top](#)

Printing on Envelopes

Explains how to print on envelopes.

[See Printing on Envelopes](#)



[Home](#) > [How to Print](#)

■ Printing Photos

- ▾ [Preparing to Print the File](#)
- ▾ [Paper Compatible with Borderless Printing](#)
- ▾ [Loading Paper](#)
- ▾ [Printing from Epson Easy Photo Print](#)
- ▾ [Printing from Other Applications](#)



Preparing to Print the File

When you print a borderless photo, part of the image will be cropped off because this option enlarges the image slightly beyond the paper size.

You need to adjust the image file to the size of the paper. If your application has margin settings, make sure they are set to zero before printing.

[Top](#)

Paper Compatible with Borderless Printing

If you want to print borderless photos, refer to the table below because borderless printing is not available for all types of paper.

Epson Photo Paper Glossy	A4 (210 × 297 mm [8.3 × 11.7 in.]), Letter (8,5 × 11 in. [21.59 × 27.94 cm]), 4 × 6 in. (10 × 15 cm)
Epson Ultra Premium Photo Paper Glossy	Letter (8,5 × 11 in. [21.59 × 27.94 cm]), 4 × 6 in. (10 × 15 cm), 5 × 7 in. (13 × 18 cm)
Epson Premium Presentation Paper Matte	Letter (8,5 × 11 in. [21.59 × 27.94 cm])
Epson Premium Photo Paper Glossy	Letter (8,5 × 11 in. [21.59 × 27.94 cm]), 4 × 6 in. (10 × 15 cm), 5 × 7 in. (13 × 18 cm), 16:9 wide size (102 × 181 mm)
Epson Premium Photo Paper Semi-gloss	Letter (8,5 × 11 in. [21.59 × 27.94 cm]), 4 × 6 in. (10 × 15 cm)

Note:

- Borderless printing takes longer than normal printing.
- Print quality may decline in the top and bottom areas of the printout, or the area may be smeared when printing on papers other than those listed above. Print a single sheet to check the quality before printing large jobs.

[Top](#) 

Loading Paper

Refer to the section below for details on loading paper.

 [Loading Paper](#)

When using special Epson paper, refer to the section below.

 [Using Special Paper](#)

[Top](#) 

Printing from Epson Easy Photo Print

Using Epson Easy Photo Print included on the CD-ROM is the easiest and quickest way to create various photos, such as borderless photos or photos with borders or frames. Epson Easy Photo Print also helps you enhance your photos.

Starting Epson Easy Photo Print

Refer to the following section for details on starting Epson Easy Photo Print.

 [Starting Epson Easy Photo Print](#)

[Top](#) 

Printing from Other Applications

Printer settings for Windows

Follow these steps to adjust your printer settings.

1 Access the printer settings.

 [Accessing the Printer Driver for Windows](#)

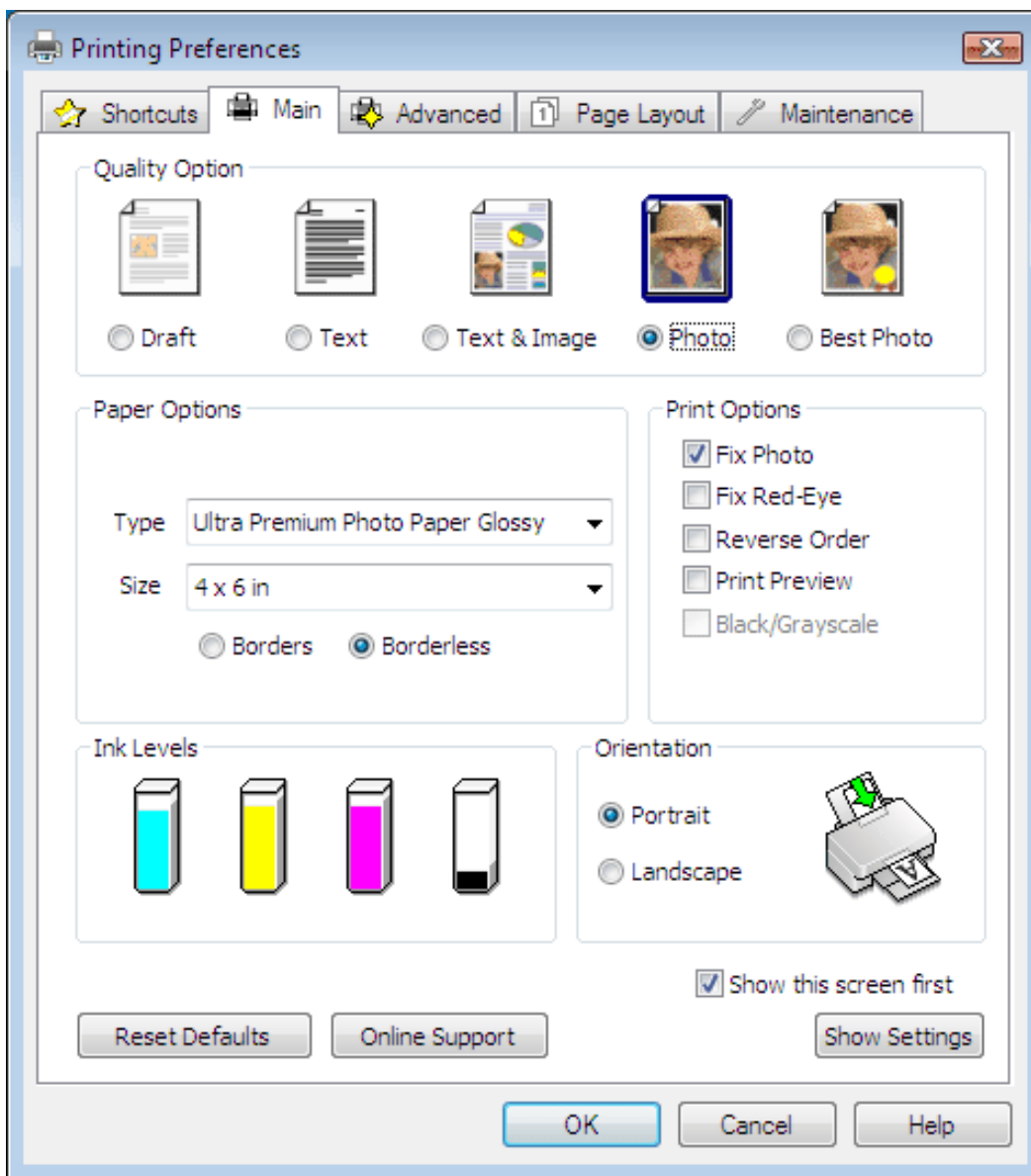

2 Click the **Main** tab, then select one of the following Quality Option settings:

- **Photo** for good quality and speed
- **Best Photo** for the best print quality

3 Select the appropriate Type setting.

 [Selecting the Correct Paper Type](#)

4 Select **Borderless** if you want to print borderless photos.

If you want to control the amount of the image that extends beyond the edges of the paper, click the **Page Layout** tab, select **Auto Expand** as the Enlargement Method, and then adjust the **Expansion** slider.

5 Select the appropriate Size setting.

6 Select **Portrait** (tall) or **Landscape** (wide) to change the orientation of your printout.

7 Click **OK** to close the printer settings window.

After completing the steps above, print one test copy and examine the results before printing an entire job.

Printer settings for Mac OS X 10.5.x

Follow these steps to adjust your printer settings.

- 1 Access the Print dialog box.

 [Accessing the Printer Driver for Mac OS X](#)

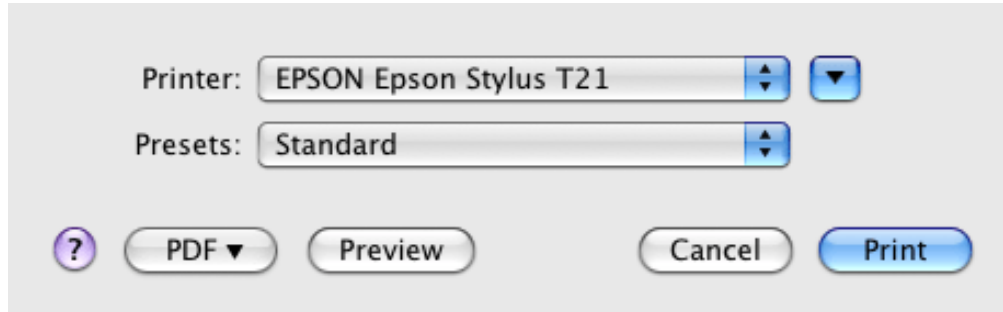

- 2 Click the  button to extend this dialog box.

- 3 Select the printer you are using as the Printer setting, and then make suitable settings.

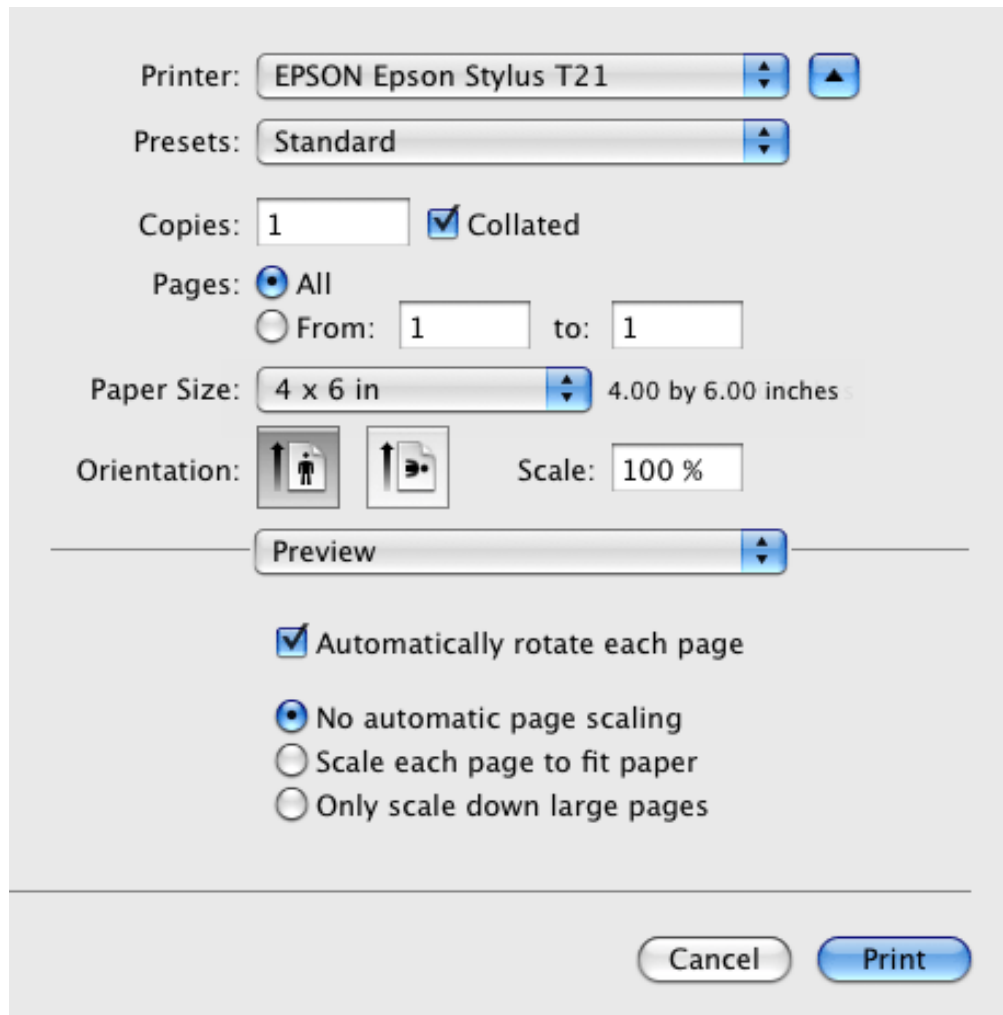

 **Note:**

- Depending on your application, you may not be able to select some of the items in this dialog box. If so, click **Page Setup** on the File menu of your application, and then make suitable settings.
- Select **XXX (Borderless)** as the Paper Size if you want to print borderless photos.

4 Select **Print Settings** from the pop-up menu.

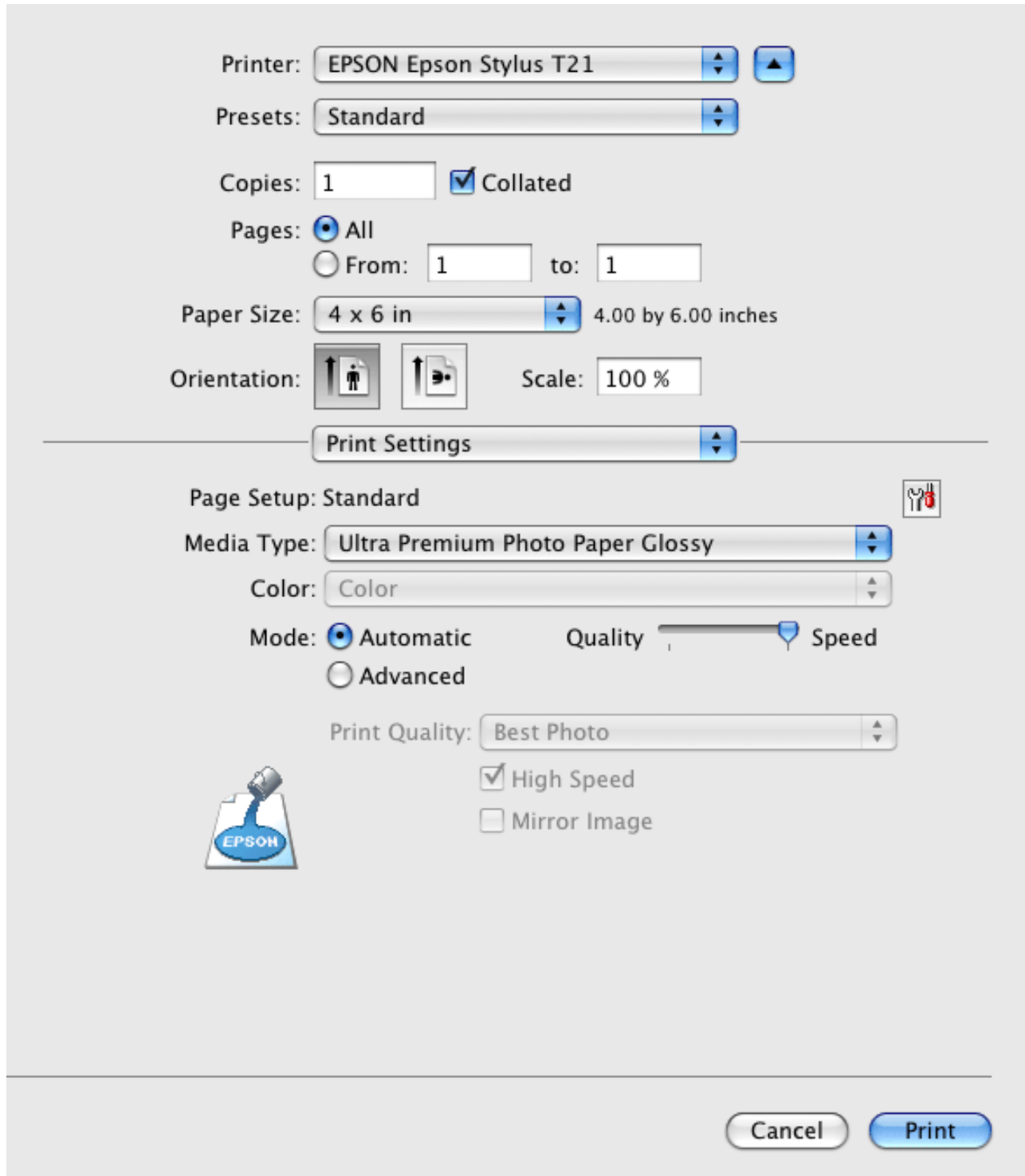

Printer: EPSON Epson Stylus T21

Presets: Standard

Copies: 1 Collated

Pages: All
 From: 1 to: 1

Paper Size: 4 x 6 in 4.00 by 6.00 inches

Orientation: Portrait Landscape Scale: 100 %

Print Settings

Page Setup: Standard

Media Type: Ultra Premium Photo Paper Glossy

Color: Color

Mode: Automatic Advanced Quality Speed

Print Quality: Best Photo

High Speed
 Mirror Image

Cancel Print

- 5 Make the settings that you want to use to print. See online help for details of Print Settings.

[Selecting the Correct Paper Type](#)

After completing the steps above, print one test copy and examine the results before printing an entire job.

Note:

You can control the amount of the image that extends beyond the edges of the paper during borderless printing. See online help for details.

Printer settings for Mac OS X 10.3.9 to 10.4.x

Follow these steps to adjust your printer settings.

- 1 Access the Page Setup dialog box.

[Accessing the Printer Driver for Mac OS X](#)

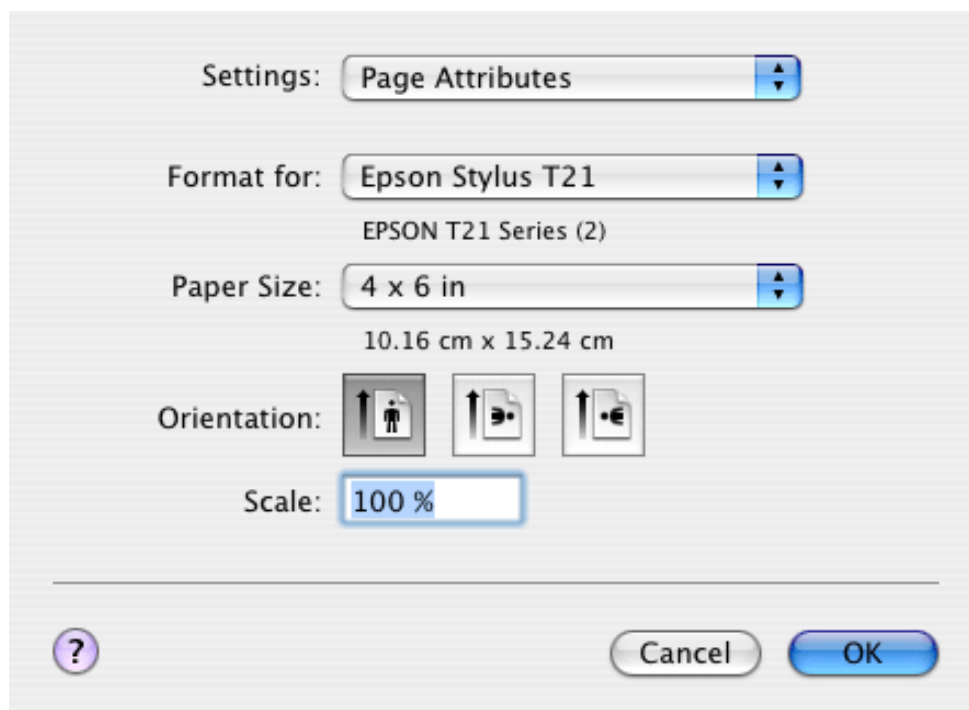

- 2 Select the printer you are using as the Format for setting.

- 3 Select the appropriate Paper Size setting.

Note:

Select **XXX (Borderless)** if you want to print borderless photos.

- 4 Select the appropriate Orientation settings.

5 Click **OK** to close the Page Setup dialog box.

6 Access the Print dialog box.

 [Accessing the Printer Driver for Mac OS X](#)

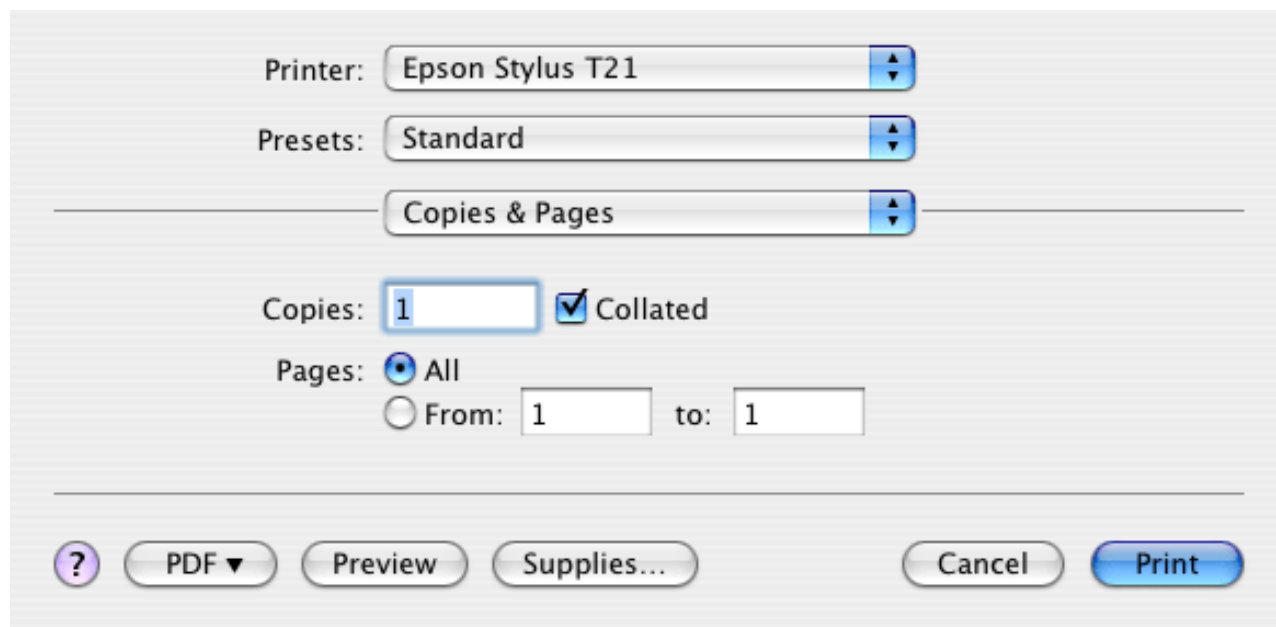

7 Select the printer you are using as the Printer setting. Then make the Copies & Pages settings.

8 Select **Print Settings** from the pop-up menu.

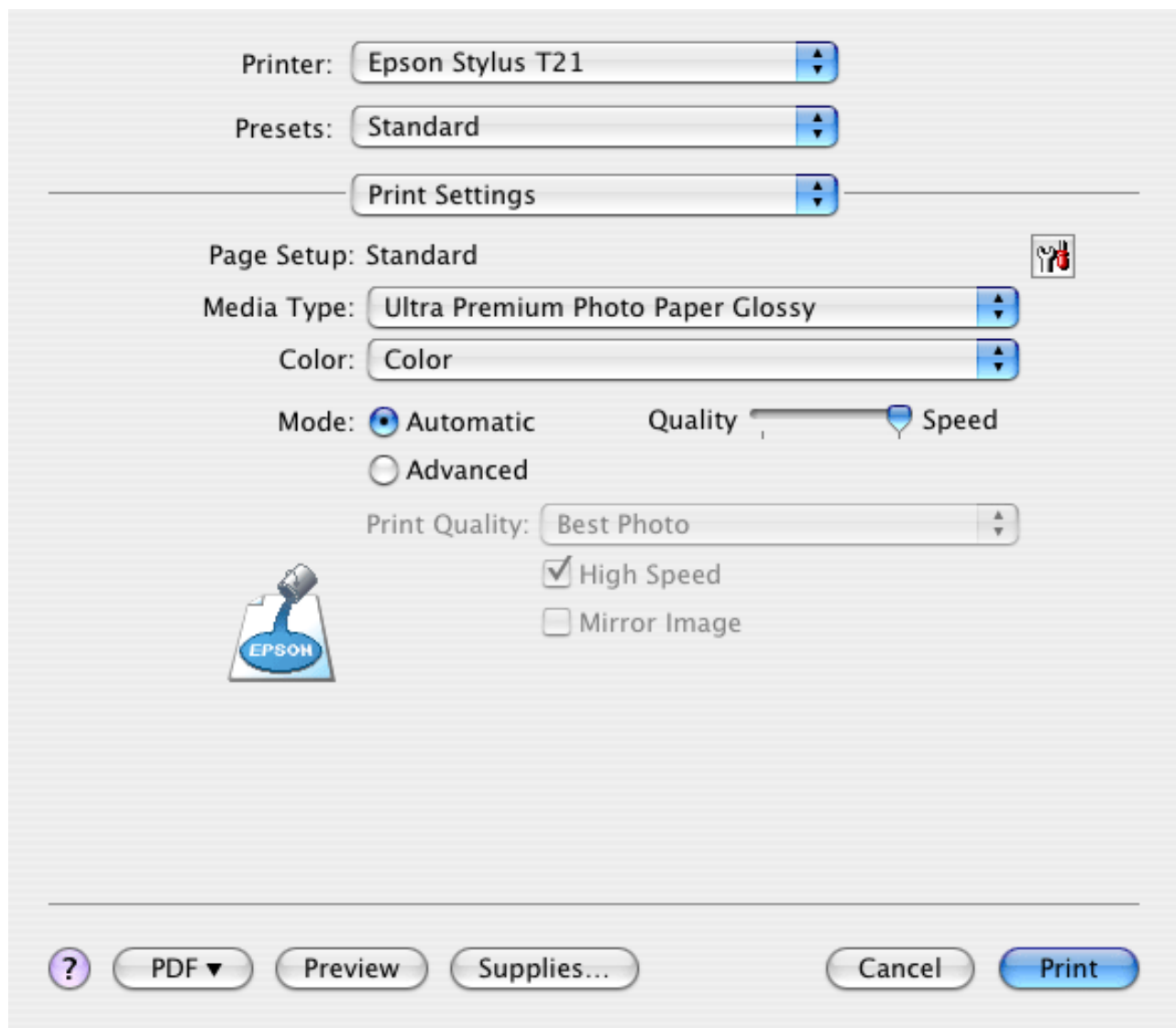

9 Select the appropriate Media Type, Color, and Mode settings. See online help for details of **Print Settings**.

 [Selecting the Correct Paper Type](#)

After completing the steps above, print one test copy and examine the results before printing an entire job.

 **Note:**

You can control the amount of the image that extends beyond the edges of the paper during borderless printing. See online help for details.

[Home](#) > [How to Print](#)

■ **Printing Documents**

- [↕ Loading Paper](#)
- [↕ Printer Settings for Windows](#)
- [↕ Printer Settings for Mac OS X 10.5.x](#)
- [↕ Printer Settings for Mac OS X 10.3.9 to 10.4.x](#)



Loading Paper

Refer to the section below for details on loading paper.

 [Loading Paper](#)

When using special Epson paper, refer to the section below.

 [Using Special Paper](#)

[Top](#) 

Printer Settings for Windows

1 Open the file you want to print.

2 Access the printer settings.

 [Accessing the Printer Driver for Windows](#)

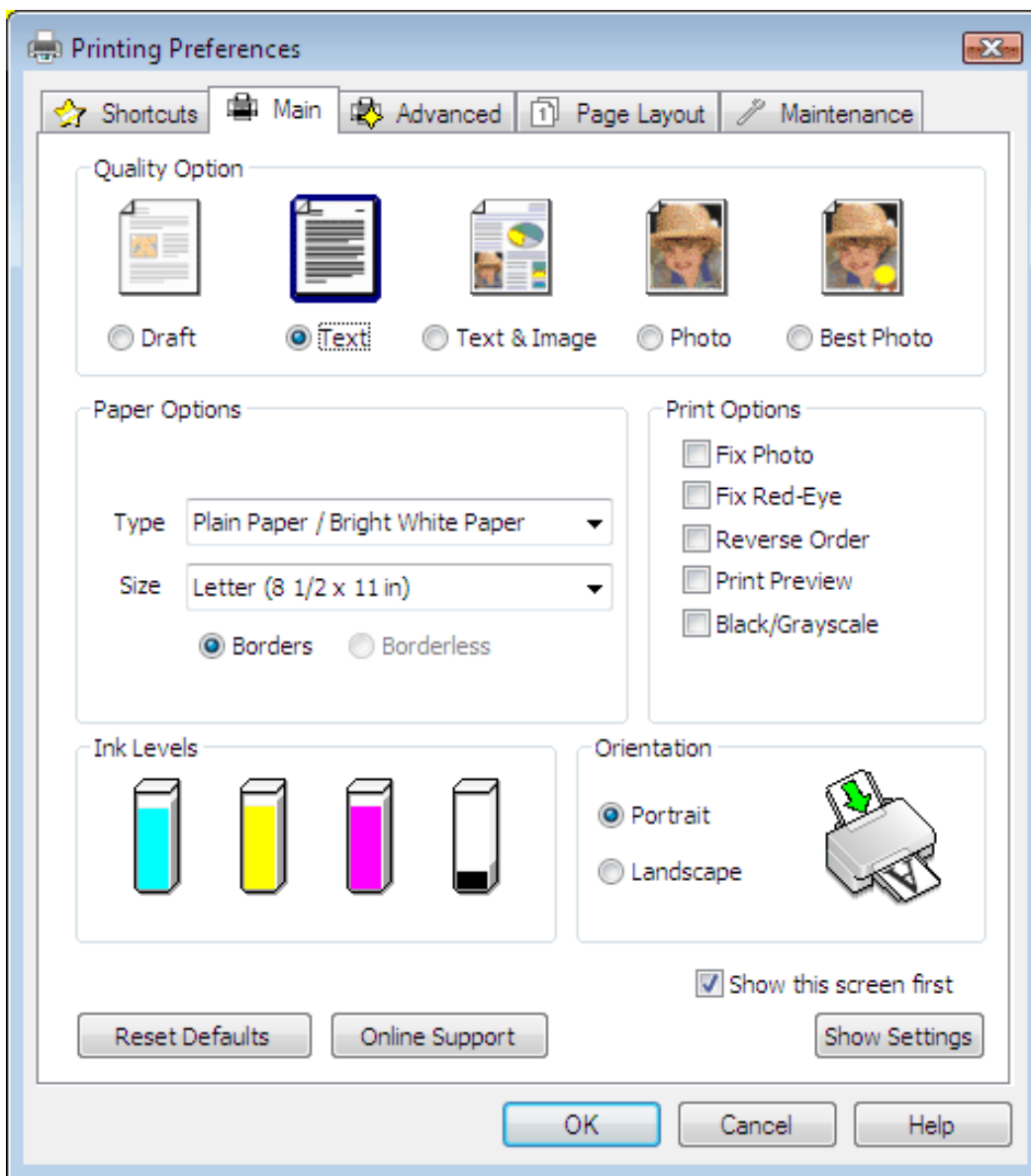

- 3 Click the **Main** tab, then select one of the following Quality Option settings:
 - **Draft** for rough drafts with reduced print quality
 - **Text** for text-only documents with higher text quality
 - **Text & Image** for higher quality documents with text and images
- 4 Select the appropriate Type setting.
 [Selecting the Correct Paper Type](#)
- 5 Select the appropriate Size setting. You can also define a custom paper size. For details, see the online help.
- 6 Select **Portrait** (tall) or **Landscape** (wide) to change the orientation of your printout.
- 7 Click **OK** to close the printer settings window.
- 8 Print your file.

Printer Settings for Mac OS X 10.5.x

Follow these steps to adjust your printer settings.

1 Open the file you want to print.

2 Access the Print dialog box.

 [Accessing the Printer Driver for Mac OS X](#)

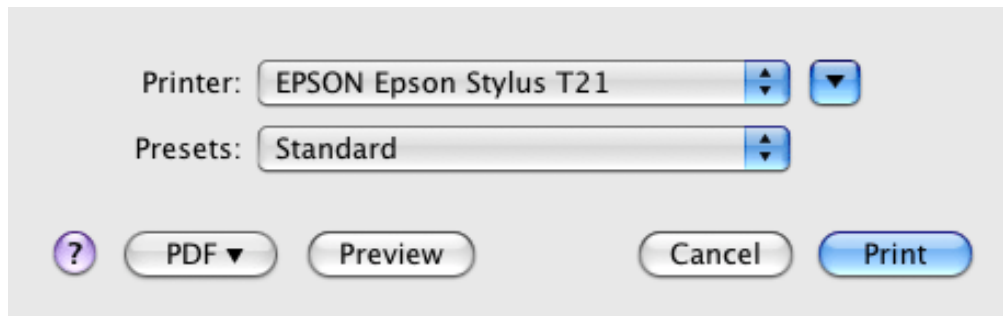

3 Click the  button to extend this dialog box.

4 Select the printer you are using as the Printer setting, and then make suitable settings.

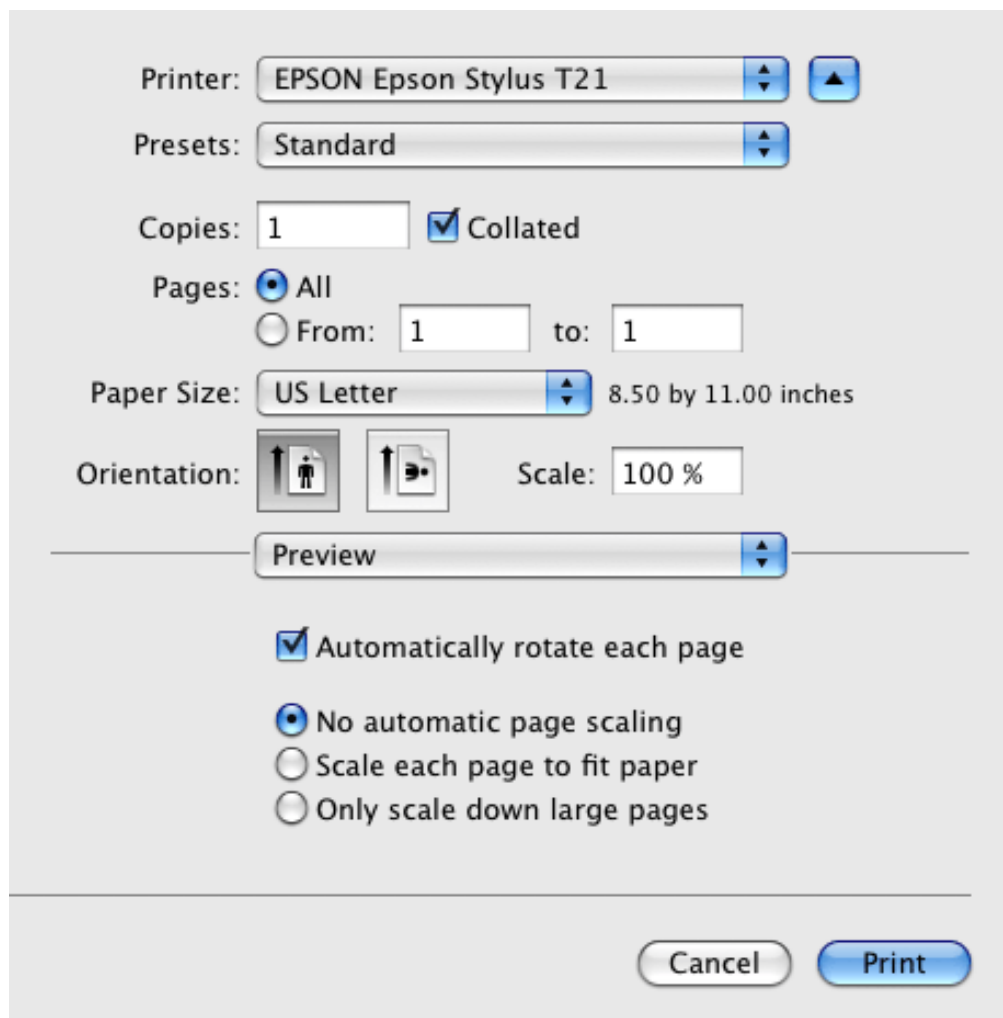

Cancel

Print

 **Note:**

Depending on your application, you may not be able to select some of the items in this dialog box. If so, click **Page Setup** on the File menu of your application, and then make suitable settings.

5 Select **Print Settings** from the pop-up menu.

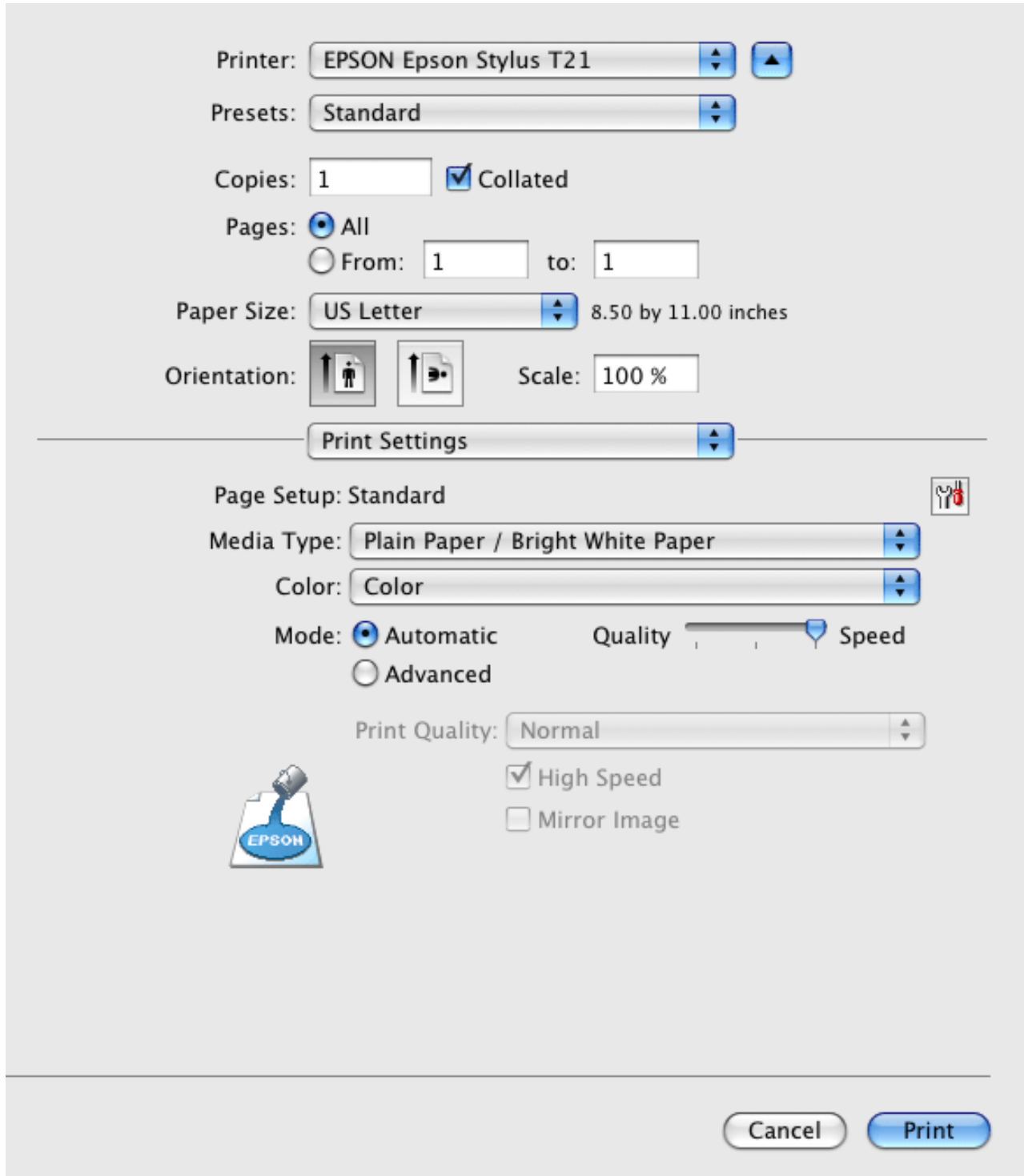



Printer: EPSON Epson Stylus T21

Presets: Standard

Copies: 1 Collated

Pages: All
 From: 1 to: 1

Paper Size: US Letter 8.50 by 11.00 inches

Orientation:   Scale: 100 %

Print Settings

Page Setup: Standard 

Media Type: Plain Paper / Bright White Paper

Color: Color

Mode: Automatic Advanced

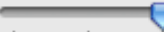
Quality  Speed

Print Quality: Normal

High Speed
 Mirror Image



Cancel Print

6 Make the settings that you want to use to print. See online help for details of Print Settings.

 [Selecting the Correct Paper Type](#)

7 Click **Print** to start printing.

[Top](#) 

Printer Settings for Mac OS X 10.3.9 to 10.4.x

1 Open the file you want to print.

2 Access the Page Setup dialog box.

 [Accessing the Printer Driver for Mac OS X](#)

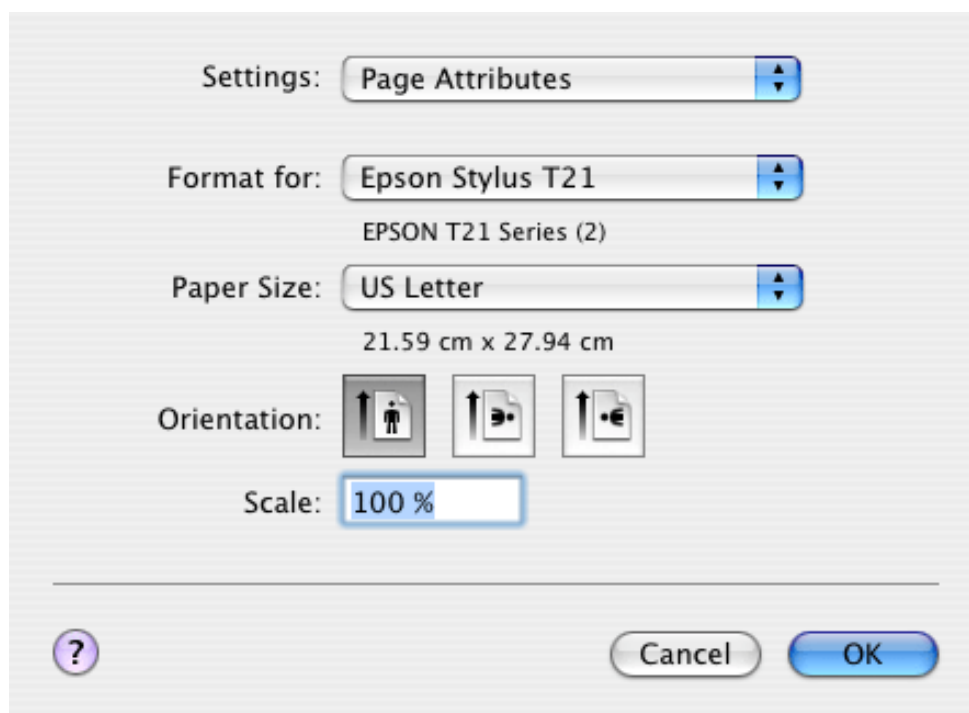

3 Select the printer you are using as the Format for setting.

4 Select the appropriate Paper Size and Orientation settings. You can also define a custom paper size. For details, see the online help.

5 Click **OK** to close the Page Setup dialog box.

6 Access the Print dialog box.

 [Accessing the Printer Driver for Mac OS X](#)

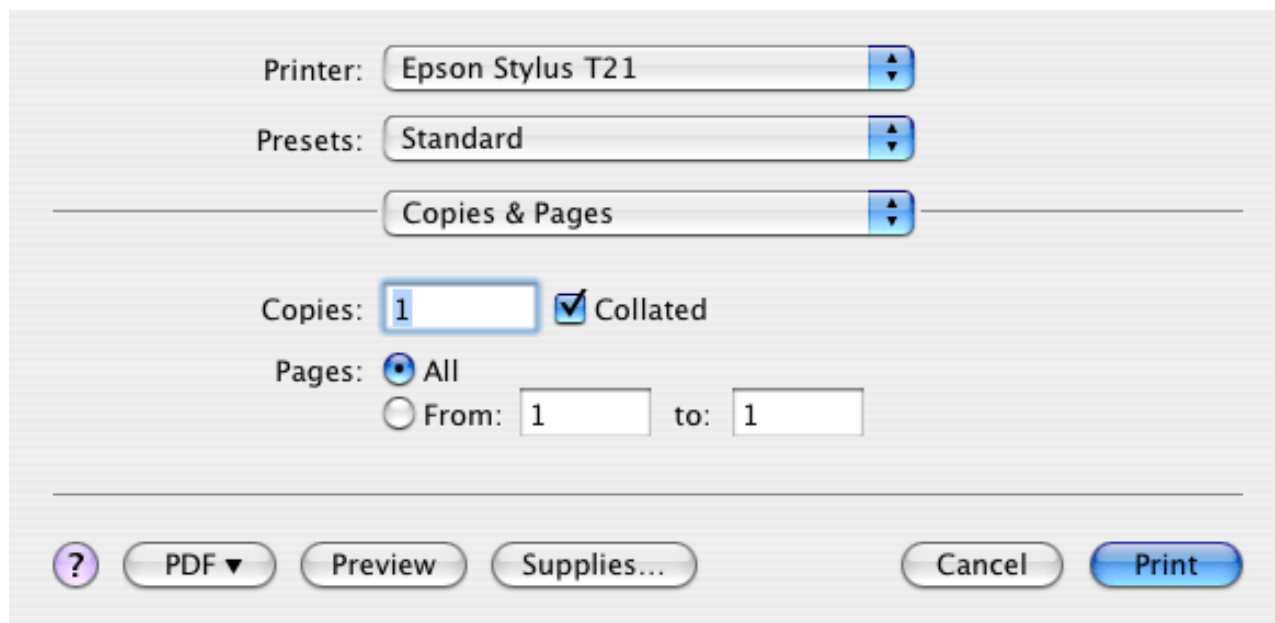

7 Select the printer you are using as the Printer setting. Then make the Copies & Pages settings.

8 Select **Print Settings** from the pop-up menu.

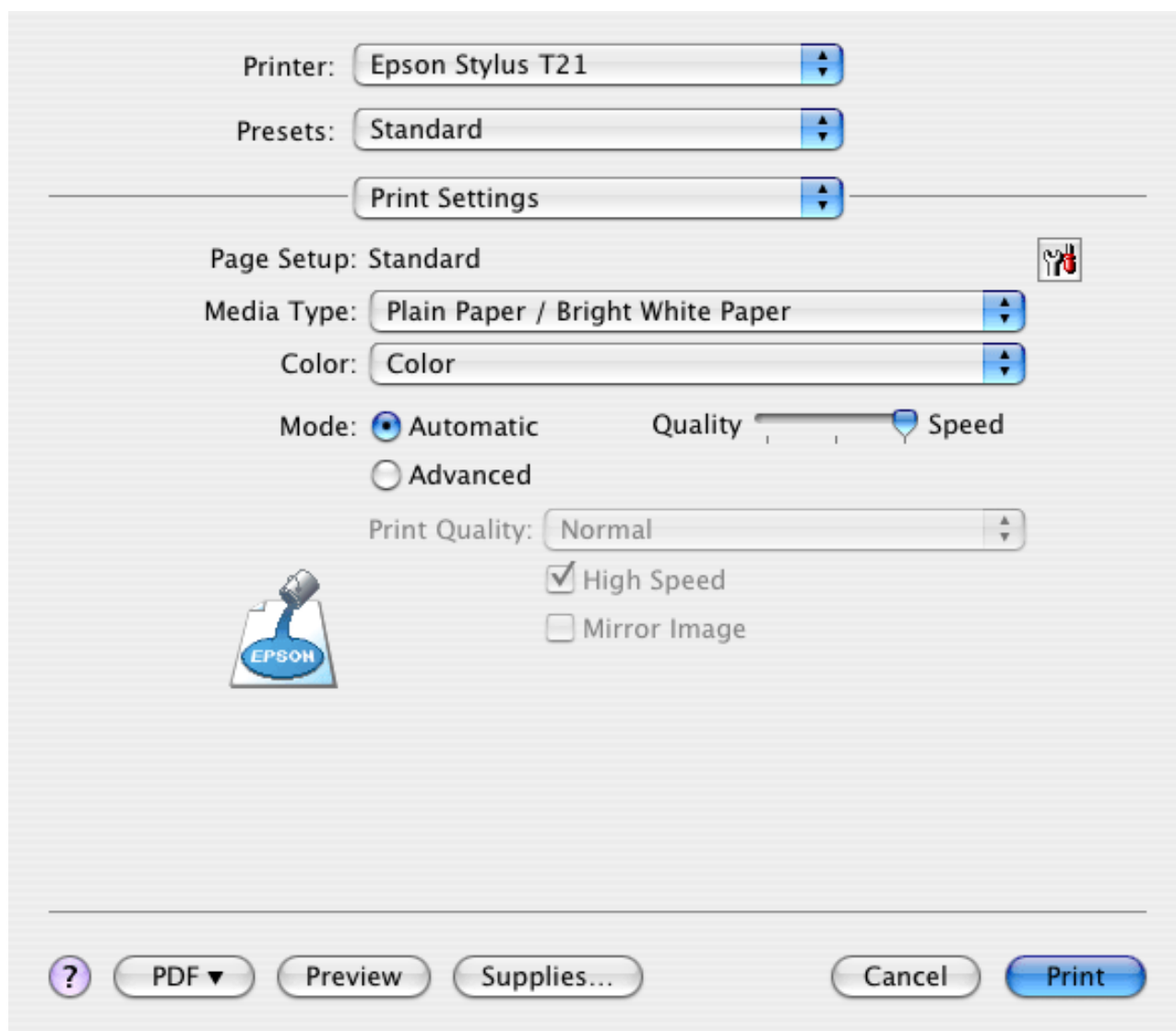

9 Select the appropriate Media Type, Color, and Mode settings. See online help for details of **Print Settings**.



[Selecting the Correct Paper Type](#)

10 Click **Print** to start printing.

[Home](#) > [How to Print](#)

■ Printing Web Pages

[↕ Loading Paper](#)[↕ Using EPSON Web-To-Page](#)

Loading Paper

Refer to the section below for details on loading paper.

[📄 Loading Paper](#)

When using special Epson paper, refer to the section below.

[📄 Using Special Paper](#)[Top](#) 

Using EPSON Web-To-Page

The EPSON Web-To-Page software lets you print Web pages so that they fit within the width of your selected paper.

Note for Windows users:

- - This software is not available for Windows Vista or Windows XP x64.
- - Printing web pages to fit to your paper size is a standard feature in Windows Internet Explorer 7.

Note for Mac OS X users:

- - This software is not available for Mac OS X.
- - Macintosh users can print Web pages using the printer driver.
 - ➔ See [Printer settings for Mac OS X 10.3.9 to 10.4.x](#)

1 In Internet Explorer, go to the Web page you want to print.

If you have installed EPSON Web-To-Page, the EPSON Web-To-Page toolbar appears on the Internet Explorer window.

2 Click the **Print** button on the toolbar. The Print window appears.

 **Note:**

If you want to preview the layout of your printout, click the **Print Preview** button on the toolbar.

3 Right-click the printer icon and choose **Printing Preferences**.

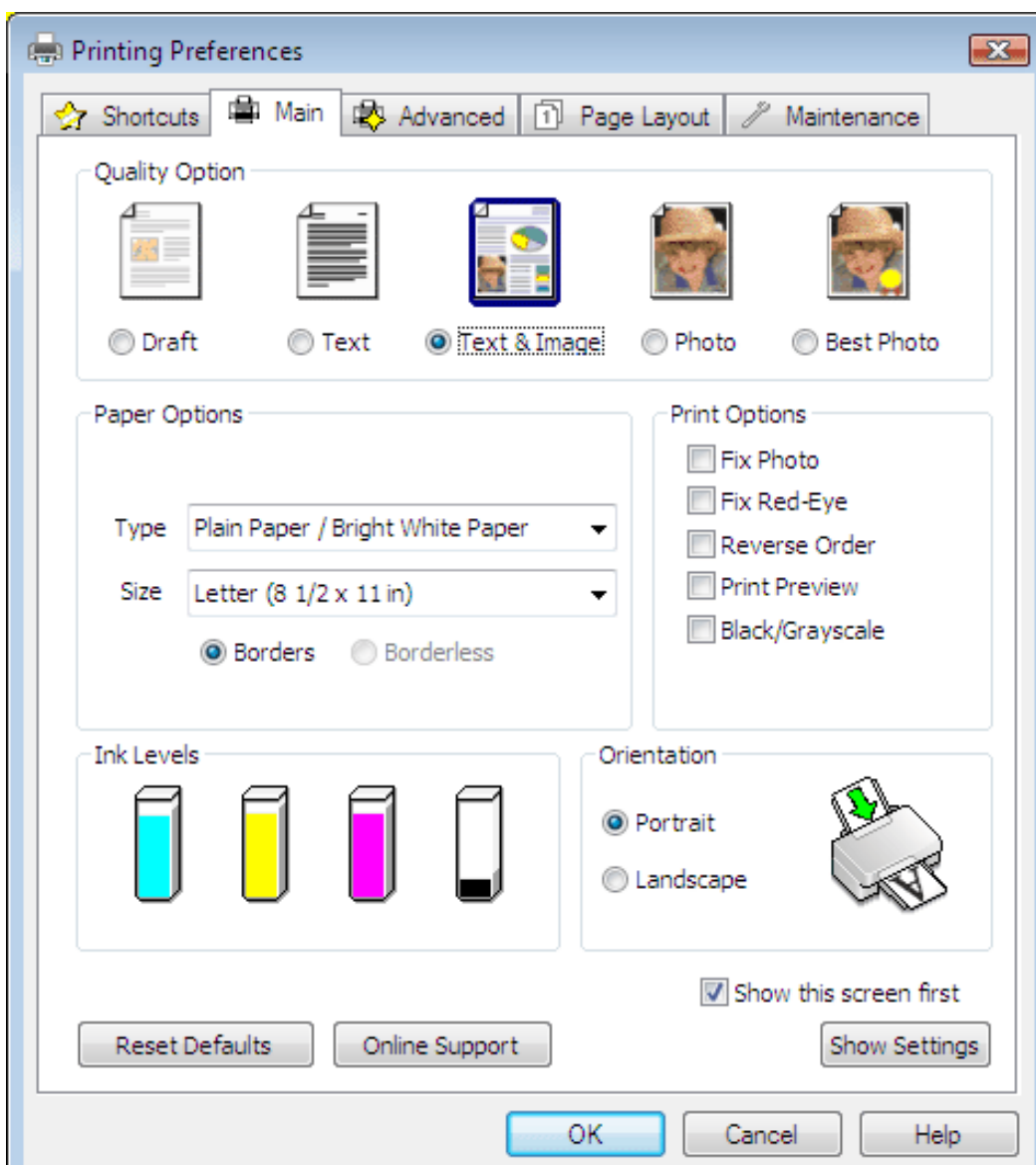

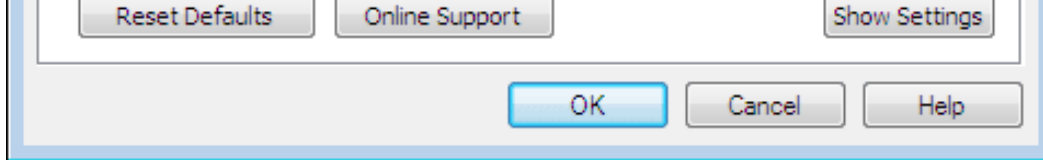

4 Click the **Main** tab, then select one of the following Quality Option settings:

- **Draft** for rough drafts with reduced print quality
- **Text** for text-only pages with higher text quality
- **Text & Image** for higher quality pages with text and images

5 Select the appropriate Type setting.

 [Selecting the Correct Paper Type](#)

6 Select the appropriate Size setting. You can also define a custom paper size. For details, see the online help.

7 Select **Portrait** (tall) or **Landscape** (wide) to change the orientation of your printout.

8 Click **OK** to close the printer settings window.

9 Print your page.

[Home](#) > [How to Print](#)

■ Printing on Envelopes

- [⌵ Loading Envelopes](#)
- [⌵ Printer Settings for Windows](#)
- [⌵ Printer Settings for Mac OS X 10.5.x](#)
- [⌵ Printer Settings for Mac OS X 10.3.9 to 10.4.x](#)



Loading Envelopes

Refer to the section below for loading envelopes.

[📄 Loading Envelopes](#)

Refer to the section below for the printable area.

[📄 Printable Area](#)

[Top](#)

Printer Settings for Windows

1 Access the printer settings.

[📄 Accessing the Printer Driver for Windows](#)

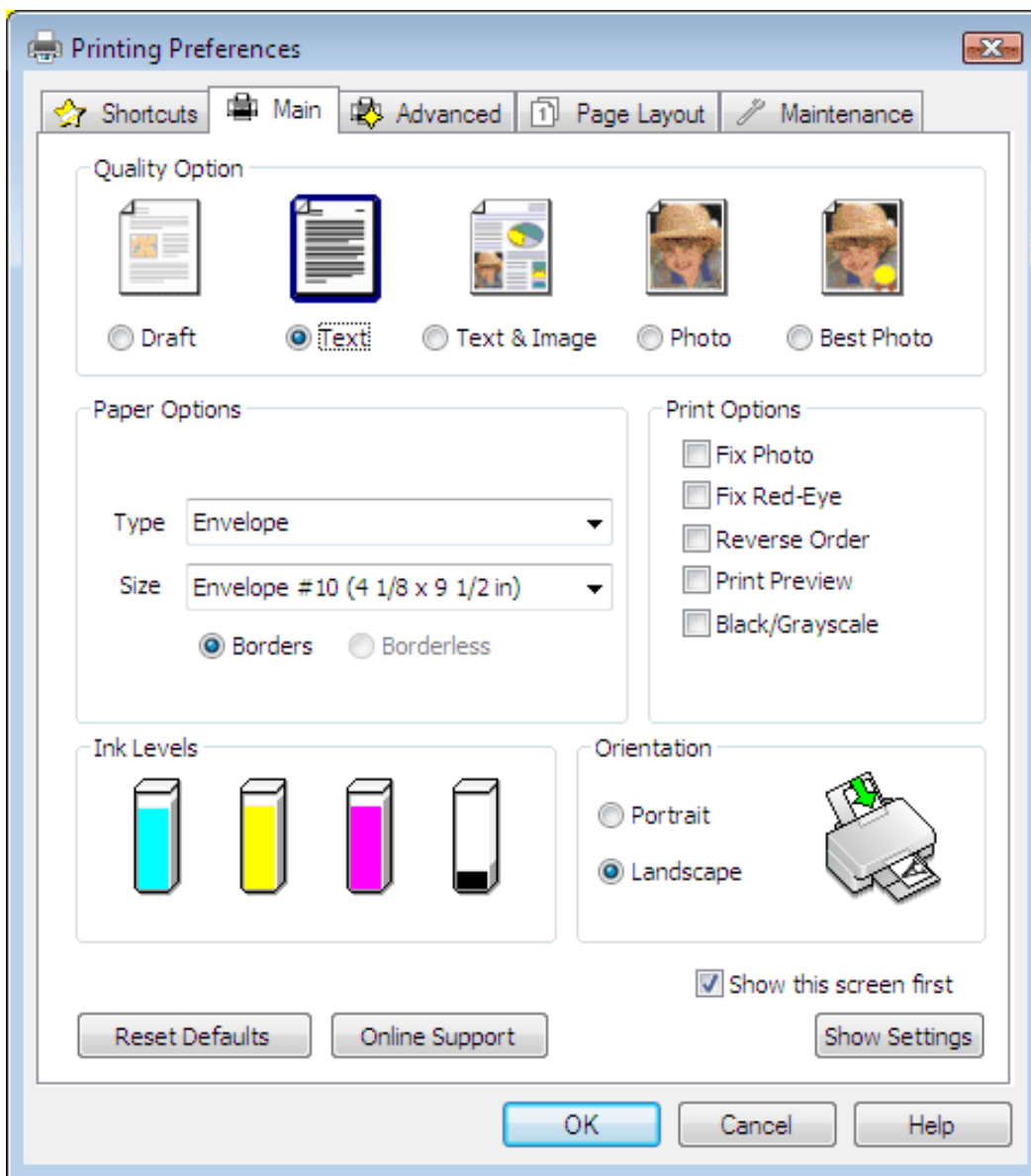

- 2 Click the **Main** tab, then select one of the following Quality Option settings:
 - **Text** for most envelopes
 - **Text & Image** to print images on the envelope
- 3 Select **Envelope** as the Type setting.
- 4 Select the appropriate envelope size from the available Size settings. You can also define a custom size. For details, see the online help.
- 5 Select **Landscape** as the Orientation setting.
- 6 Click **OK** to close the printer settings window.
- 7 Print your envelope.

Printer Settings for Mac OS X 10.5.x

Follow these steps to adjust your printer settings.

- 1 Access the Print dialog box.

 [Accessing the Printer Driver for Mac OS X](#)

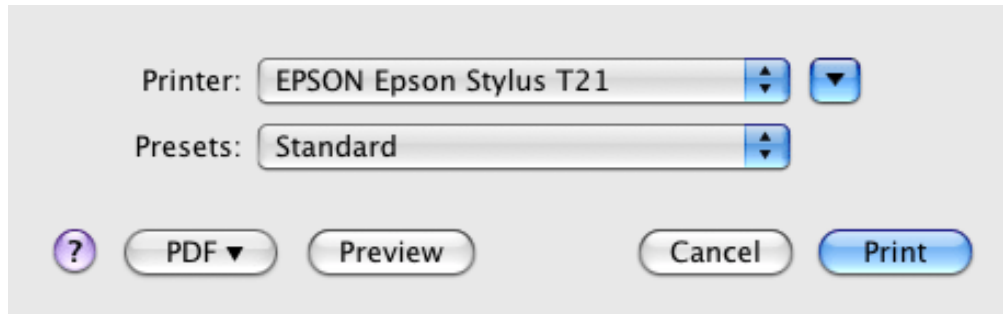

- 2 Click the  button to extend this dialog box.
- 3 Select the printer you are using as the Printer setting, and then select a suitable envelope size as the Paper Size setting. You can also define a custom envelope size. For details, see the online help.
- 4 Select **Landscape** as the Orientation setting.

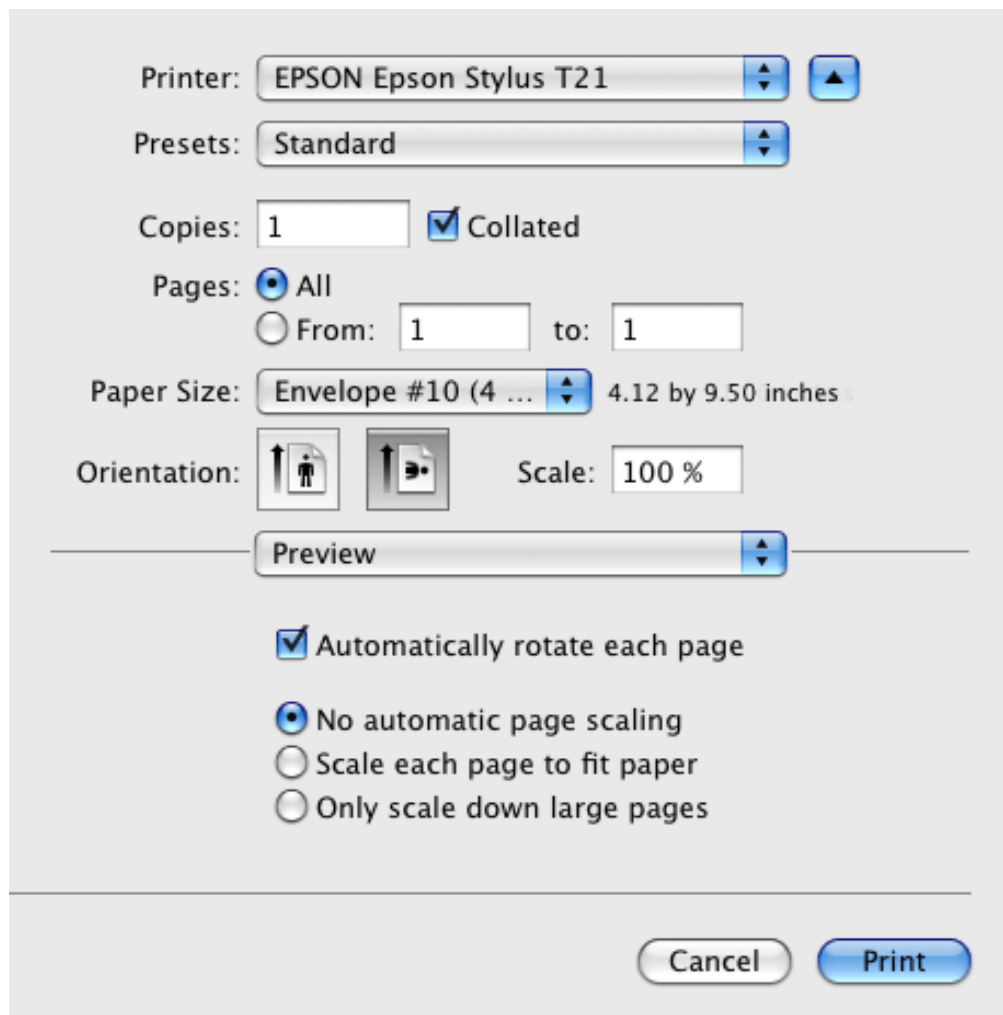

 **Note:**

Depending on your application, you may not be able to select some of the items in this dialog box. If so, click **Page Setup** on the File menu of your application, and then make suitable settings.

5 Select Print Settings from the pop-up menu.

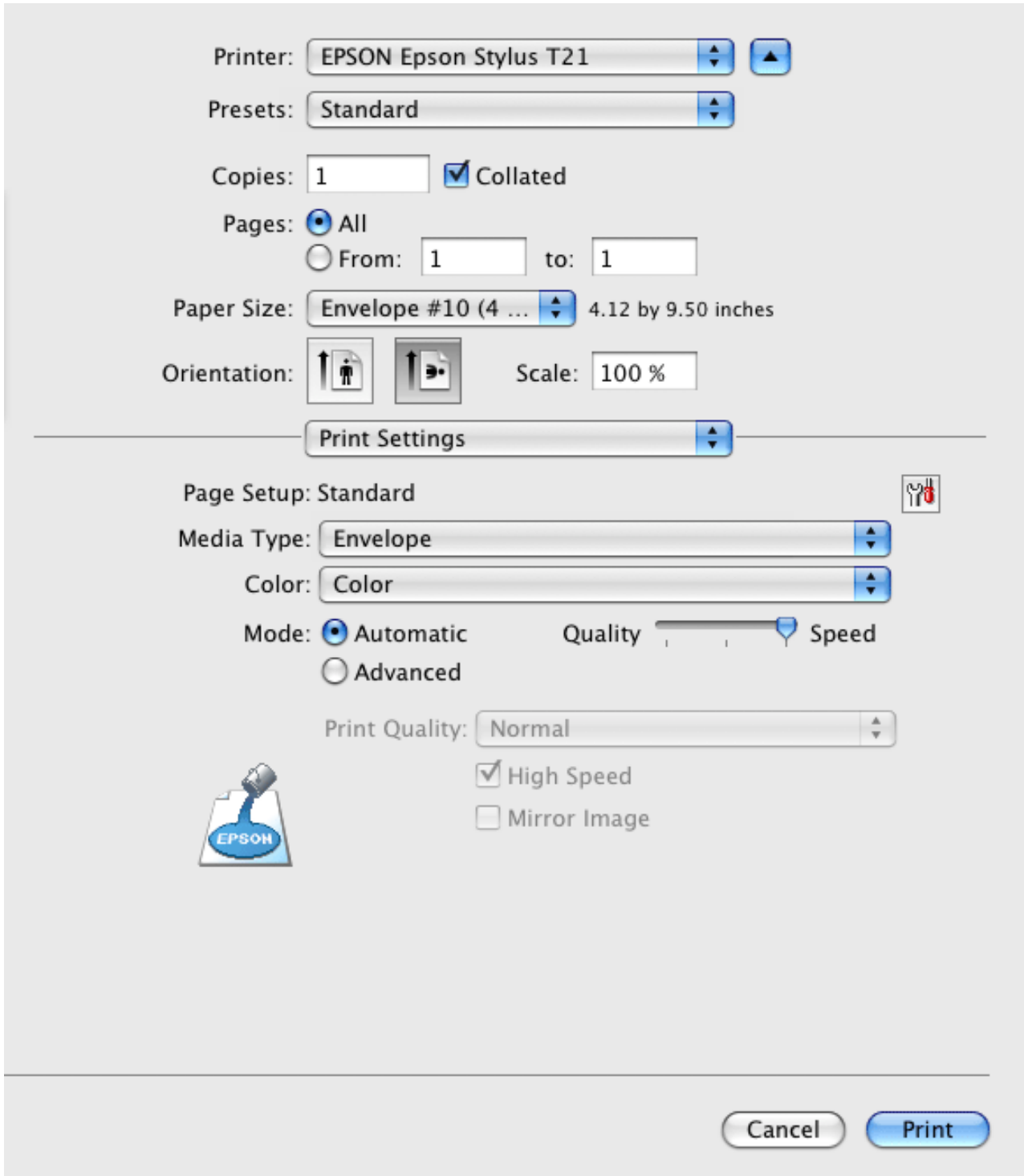

6 Make the settings that you want to use to print. See online help for details of Print Settings.

7 Click **Print** to start printing.

Top 

Printer Settings for Mac OS X 10.3.9 to 10.4.x

1 Access the Page Setup dialog box.

 [Accessing the Printer Driver for Mac OS X](#)

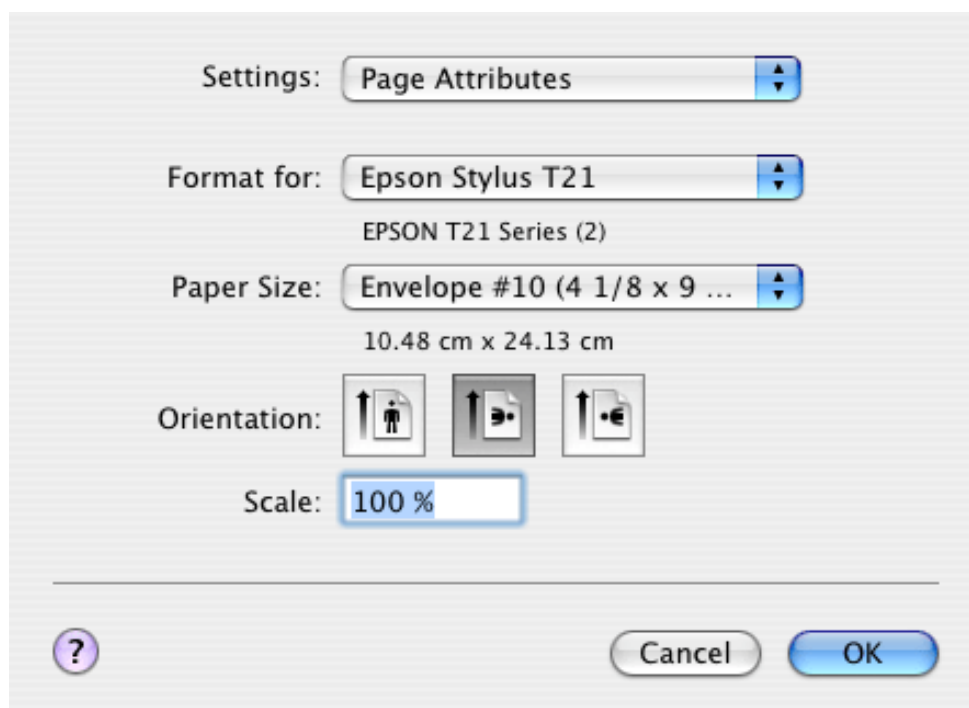

2 Select the printer you are using as the Format for setting.

3 Select the appropriate envelope size as the Paper Size setting. You can also define a custom envelope size. For details, see the online help.

4 Select **Landscape** as the Orientation setting.

5 Click **OK** to close the Page Setup dialog box.

6 Access the Print dialog box.

 [Accessing the Printer Driver for Mac OS X](#)

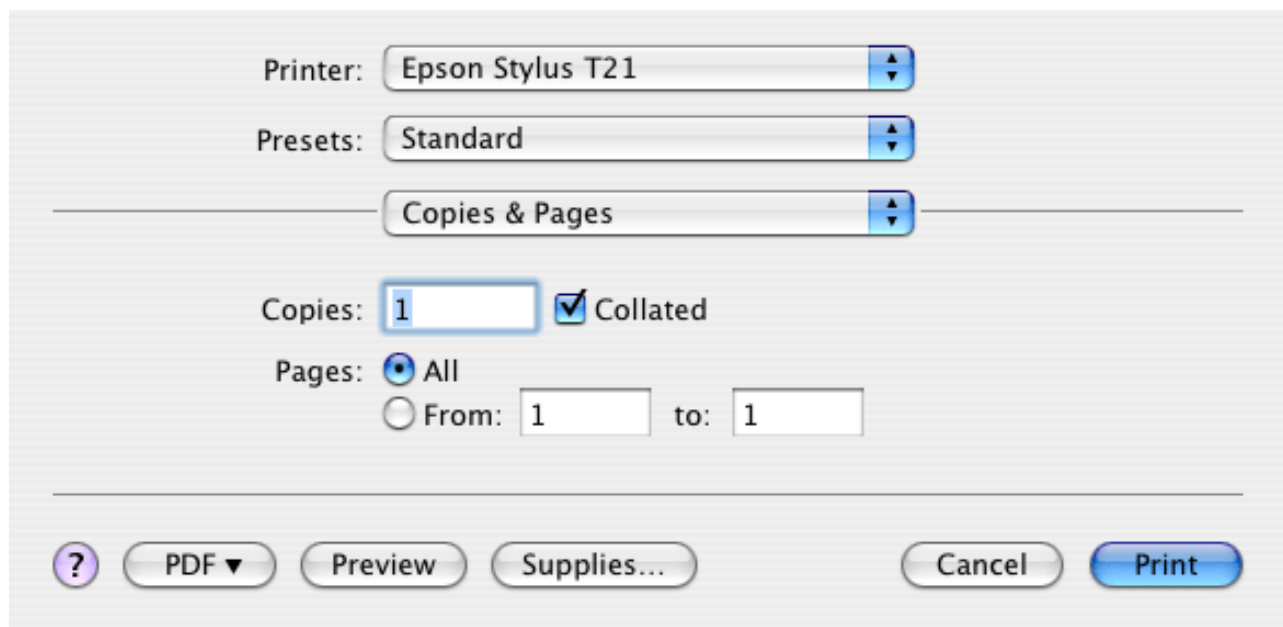

7 Select the printer you are using as the Printer setting, then make the Copies & Pages settings.

8 Select **Print Settings** from the pop-up menu.

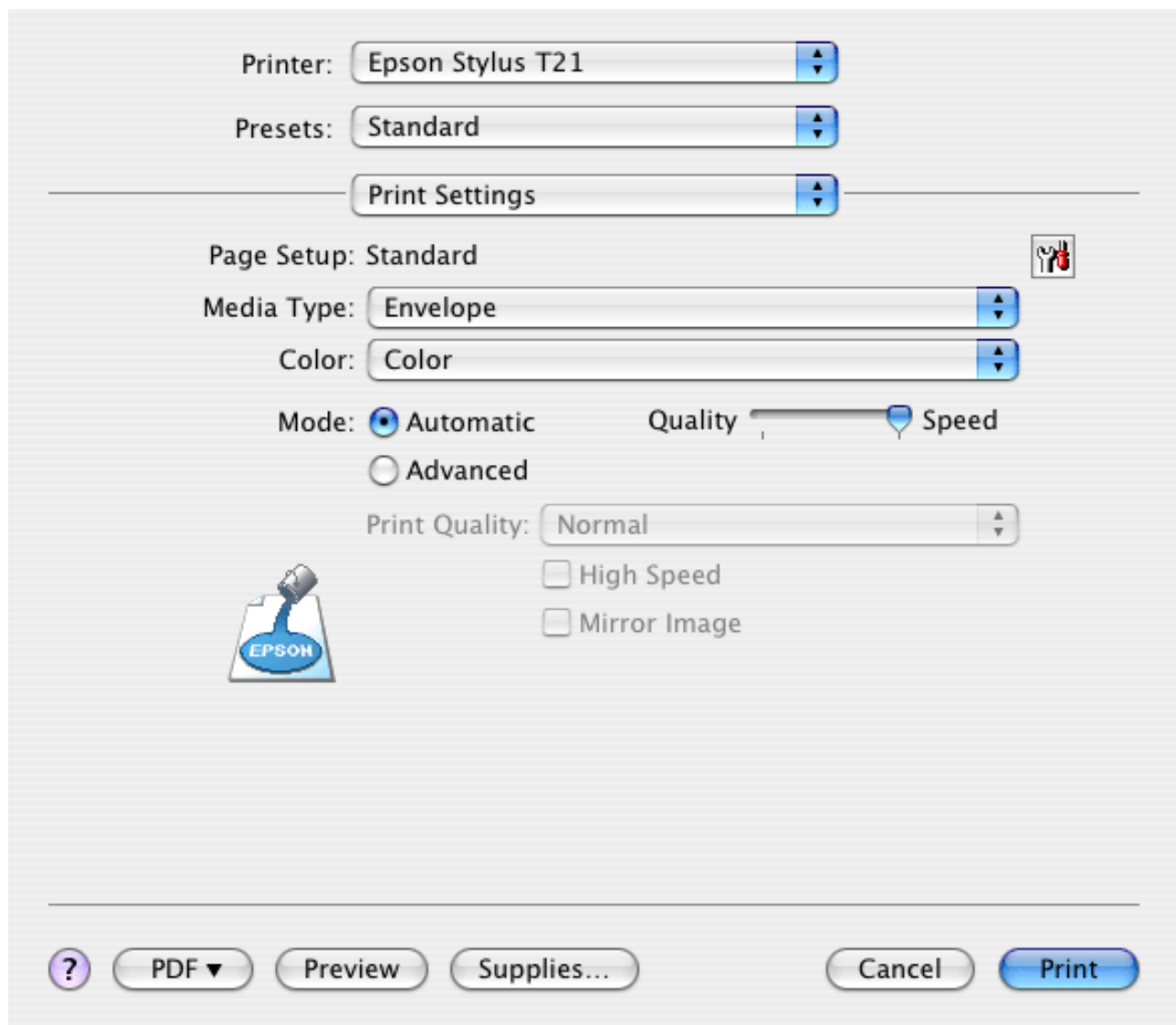

9 Select **Envelope** as the Media Type setting, then select the appropriate Color and Mode settings. See online help for details on **Print Settings**.

10 Click **Print** to start printing.

[Home](#) > [How to Print](#)

■ Canceling Printing

 [Using the Printer Button](#)

 [For Windows](#)

 [For Mac OS X](#)

If you need to cancel printing, follow the instructions in the appropriate section below.

Using the Printer Button

Press the  maintenance button to cancel a print job in progress.

[Top](#) 

For Windows

 **Note:**

You cannot cancel a print job that has been sent to the printer. In this case, cancel the print job by the printer.

Using the progress meter

When you start printing, the progress meter appears on your computer screen.

Click the **Stop** button to cancel printing.

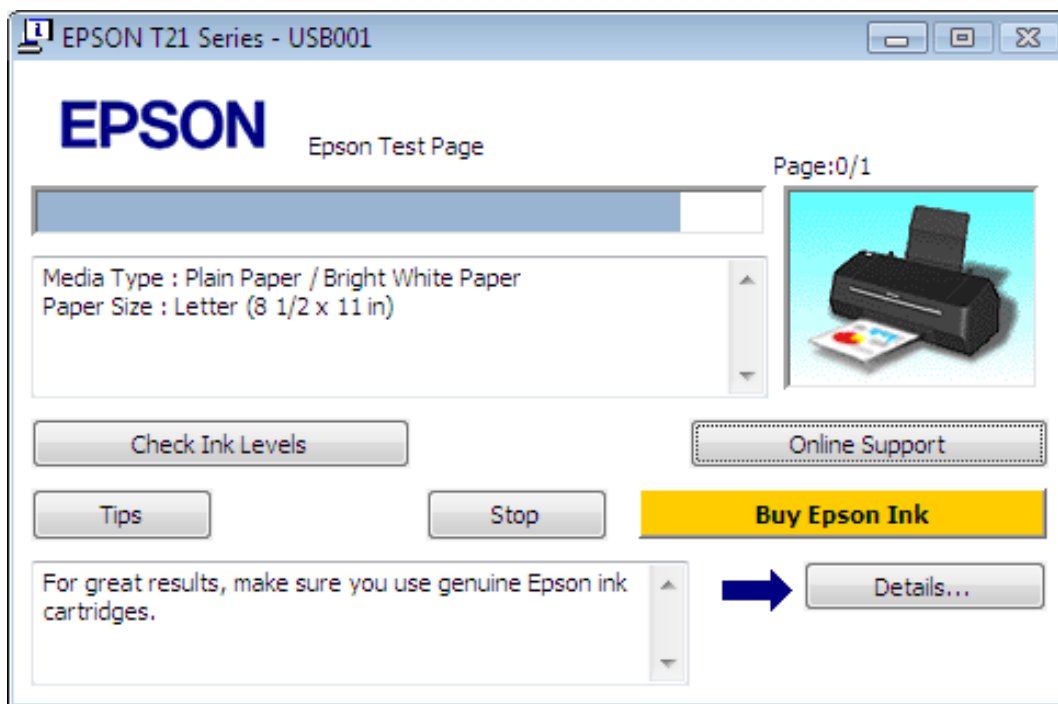

Using the Windows Spooler for Vista

- 1 Click the  button, select **Control Panel**, and then select **Printer** from the **Hardware and Sound** category.
- 2 Right click on the printer and then select **Open**.
- 3 Right click on the job you want to cancel and then select **Cancel**.

Using the Windows Spooler for XP

- 1 Click **Start**, **Control Panel**, **Printers and Other Hardware**, and then click **Printers and Faxes**.
- 2 Right click on the printer and then select **Open**.
- 3 Right click on the job you want to cancel and then select **Cancel**.

Using the Windows Spooler for 2000

- 1 Click **Start**, point to **Settings**, and then click **Printers**.
- 2 Right click on the printer and then select **Open**.
- 3 Right click on the job you want to cancel and then select **Cancel**.

[Home](#) > [How to Print](#)

Introduction

- [2-sided Printing \(Windows Only\)](#)
- [Fit to Page Printing](#)
- [Pages Per Sheet Printing](#)
- [Poster Printing \(Windows Only\)](#)
- [Watermark Printing \(Windows Only\)](#)

You can print with a variety of layouts for special projects, such as booklets and posters.

2-sided Printing (Windows Only)

Lets you print on both sides of the paper.

- [See 2-sided Printing \(Windows Only\)](#)

[Top](#)

Fit to Page Printing

Lets you automatically enlarge or reduce the size of your document to fit the paper size selected in the printer driver.

- [See Fit to Page Printing](#)

Note for Mac OS X users:

This is a standard feature of Mac OS X 10.4 and later. This feature is not available for Mac OS X 10.3.9.

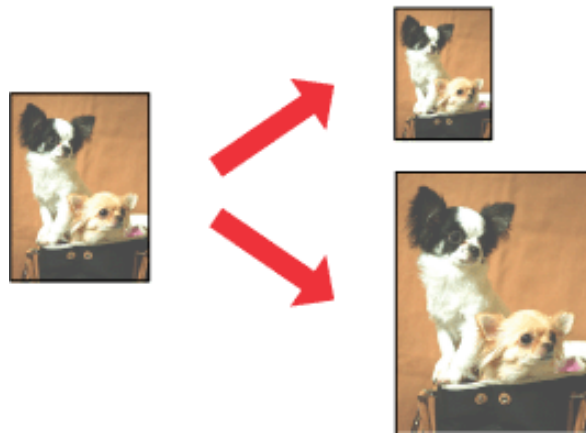

Top 

Pages Per Sheet Printing

Lets you print two or four pages on a single sheet of paper.

 [See Pages Per Sheet Printing](#)

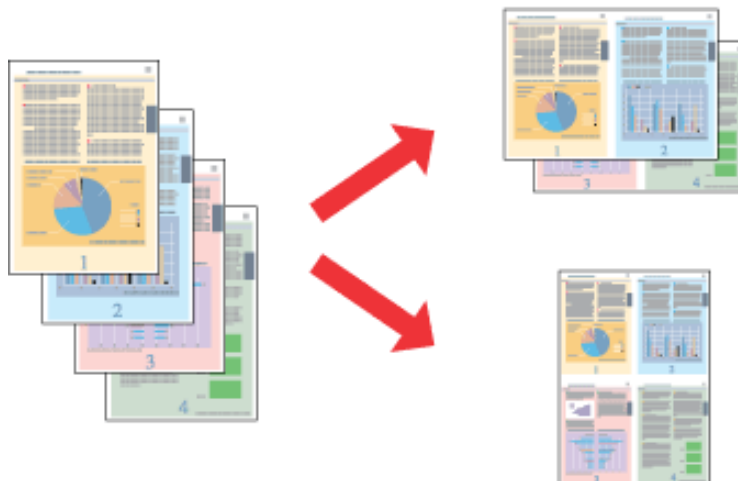

Top 

Poster Printing (Windows Only)

Lets you enlarge material on a single document page to cover 4, 9, or 16 printed sheets of paper, and then make a poster.

 [See Poster Printing \(Windows only\)](#)

 **Note:**

This feature is not available for Mac OS X.

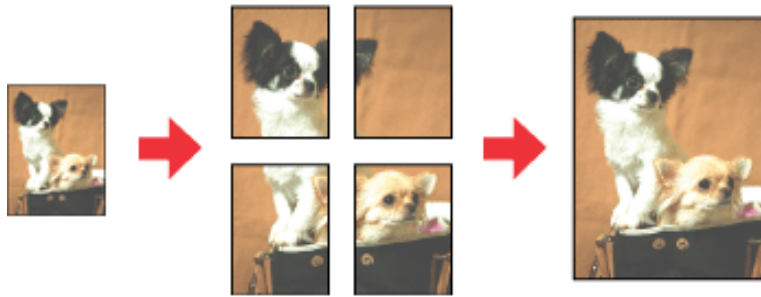

Top 

Watermark Printing (Windows Only)

Lets you print text or an image as a watermark on each page of your printout.

 See [Watermark Printing \(Windows Only\)](#)

For example, you can put "Confidential" on an important document.

Note:

This feature is not available for Mac OS X.



[Home](#) > [How to Print](#)

■ 2-sided Printing (Windows Only)

☑ Standard 2-sided Printing

☑ Folded Booklet 2-sided Printing

Two types of 2-sided printing are available: standard and folded booklet.

Standard 2-sided printing allows you to print the odd-numbered pages first. Once these pages are printed, you can reload them to print the even-numbered pages onto the opposite side of the paper.



Folded booklet 2-sided printing allows you to make single-fold booklets. The pages that will appear on the outside (after the page is folded) are printed first. The pages that will appear inside the booklet can then be printed after you reload the paper into the printer as shown in the illustration below.

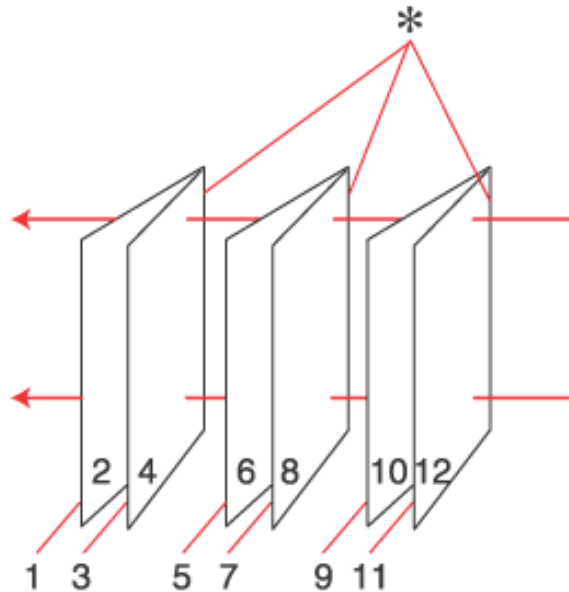

Single-fold booklet

* : Binding edge

You can create a booklet by printing pages 1 and 4 on the first sheet of paper, pages 5 and 8 on the second sheet, and pages 9 and 12 on the third sheet.

After you reload these sheets into the sheet feeder, you can then print pages 2 and 3 on the back of the first sheet of paper, pages 6 and 7 on the back of the second sheet, and pages 10 and 11 on the back of the third sheet.

The resulting pages can then be folded and bound together into a booklet.

 **Note:**

- - This feature is not available for Mac OS X.
- - This feature is not available with borderless printing.
- - This feature is not available when the printer is accessed over a network or is used as a shared printer.
- - Depending on the paper, stacks of up to 30 sheets can be loaded into the sheet feeder during 2-sided printing.
- - Only use papers that are suitable for 2-sided printing. Otherwise, the printout quality may deteriorate.
- - Depending on the paper and the amount of ink used to print text and images, ink may bleed through to the other side of the paper.
- - The surface of the paper may be smeared during 2-sided printing.

Standard 2-sided Printing

Follow the steps below to print odd- and even-numbered pages onto opposite sides of the sheet.

- 1 Access the printer settings.

 [Accessing the Printer Driver for Windows](#)

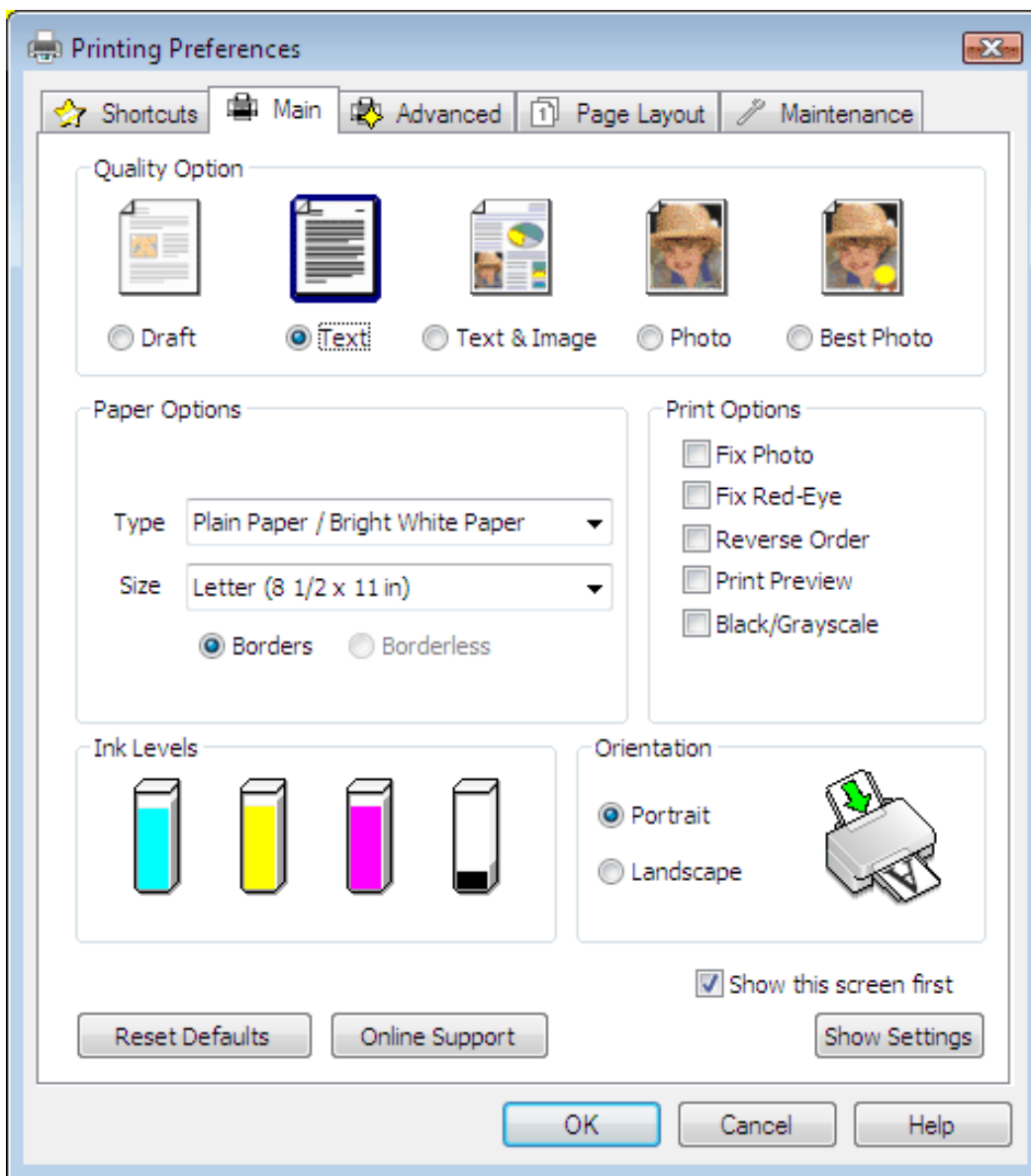

- 2 Click the **Main** tab, then select one of the following Quality Option settings:
 - **Draft** for rough drafts with reduced print quality
 - **Text** for text-only pages
 - **Text & Image** for higher quality pages with text and images
 - **Photo** for good quality and speed
 - **Best Photo** for the best print quality
- 3 Select the appropriate Type setting.
 [Selecting the Correct Paper Type](#)
- 4 Select the appropriate Size setting.
- 5 Select **Portrait** (tall) or **Landscape** (wide) to change the orientation of your printout.
- 6 Click the **Page Layout** tab, then select **On** from 2-sided printing.

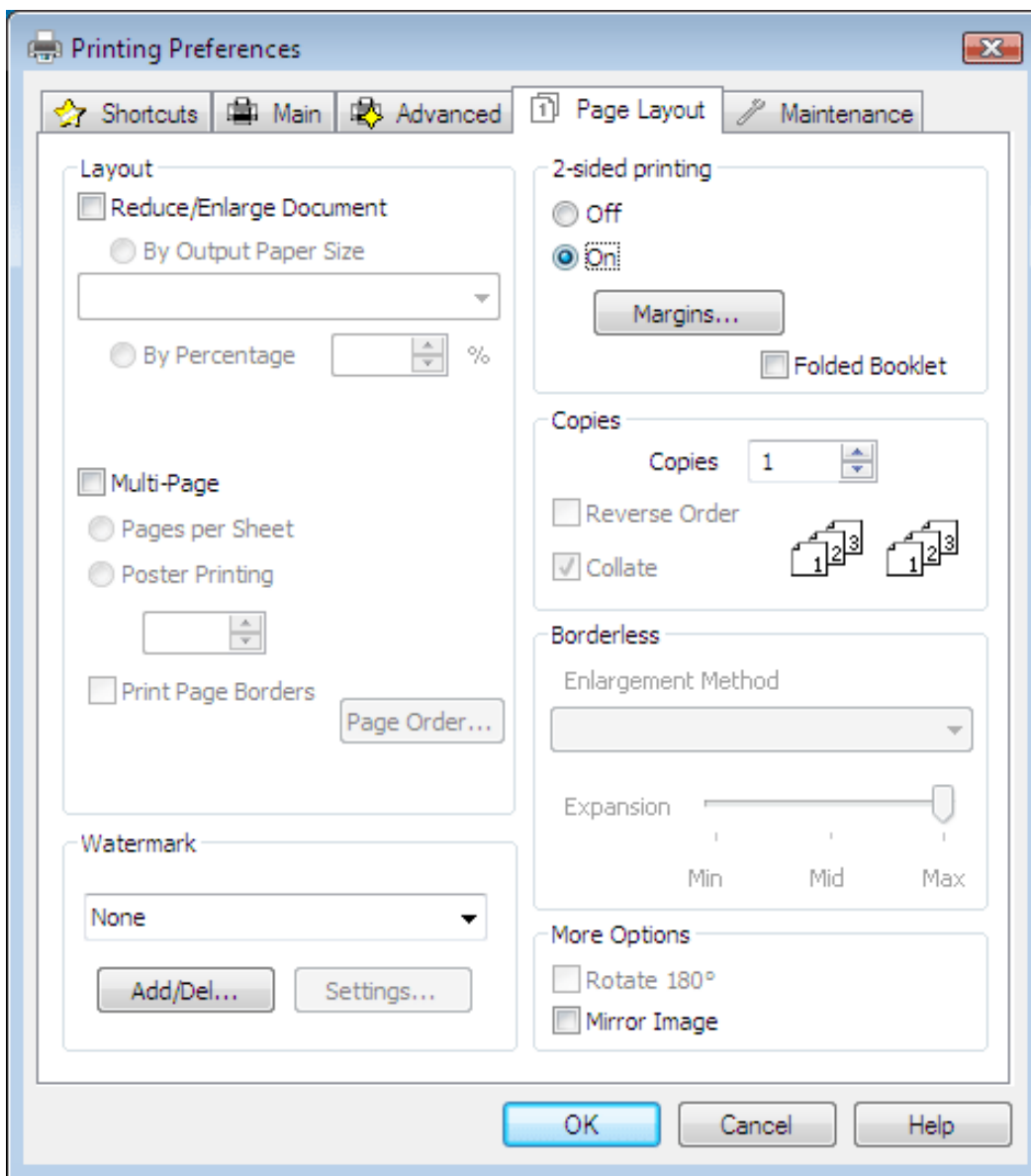

7 Click **Margins** to open the Margins window.

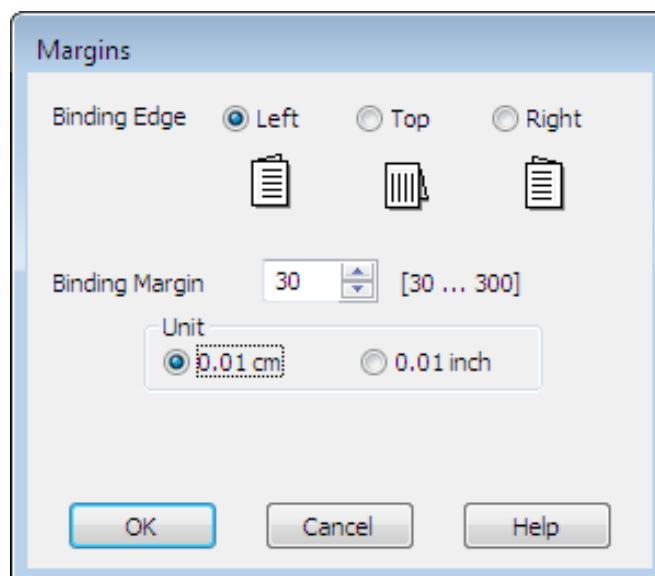

- 8 Specify the edge of the paper where the binding will be placed. You can choose **Left**, **Top**, or **Right**.
- 9 Choose **cm** or **inch** as the Unit setting. Then specify the width of the binding margin. You can enter any width from 0.3 cm to 3.0 cm, or from 0.12 inches to 1.18 inches.

 **Note:**

The actual binding margin may be different from the specified settings depending on your application. Experiment with a few sheets to examine actual results before printing the entire job.

- 10 Click **OK** to return to the Page Layout window. Then click **OK** to save your settings.
- 11 Load paper into the sheet feeder, then send the print job from your application. Instructions for generating the even-numbered pages will be displayed while the odd-numbered pages are printed.

 [Loading Paper](#)

- 12 Follow the on-screen instructions to reload the paper.

 **Note:**

- - The paper may curl during printing due to the amount of ink used. Should this occur, slightly curl the sheets in the opposite direction before reloading them.
- - Align the sheet stack by tapping its edges against a hard, flat surface before reloading the stack.
- - Follow the instructions provided when reloading the printouts. Otherwise, paper may jam or the binding margins may be incorrect.
- - If a paper jam occurs, refer to the following.
 -  See [The Paper Jams](#)

- 13 Once the paper is reloaded, click **Resume** to print the even-numbered pages.

[Top](#) 

Folded Booklet 2-sided Printing

Use the following steps to create a folded booklet.

- 1 Access the printer settings.

 [Accessing the Printer Driver for Windows](#)

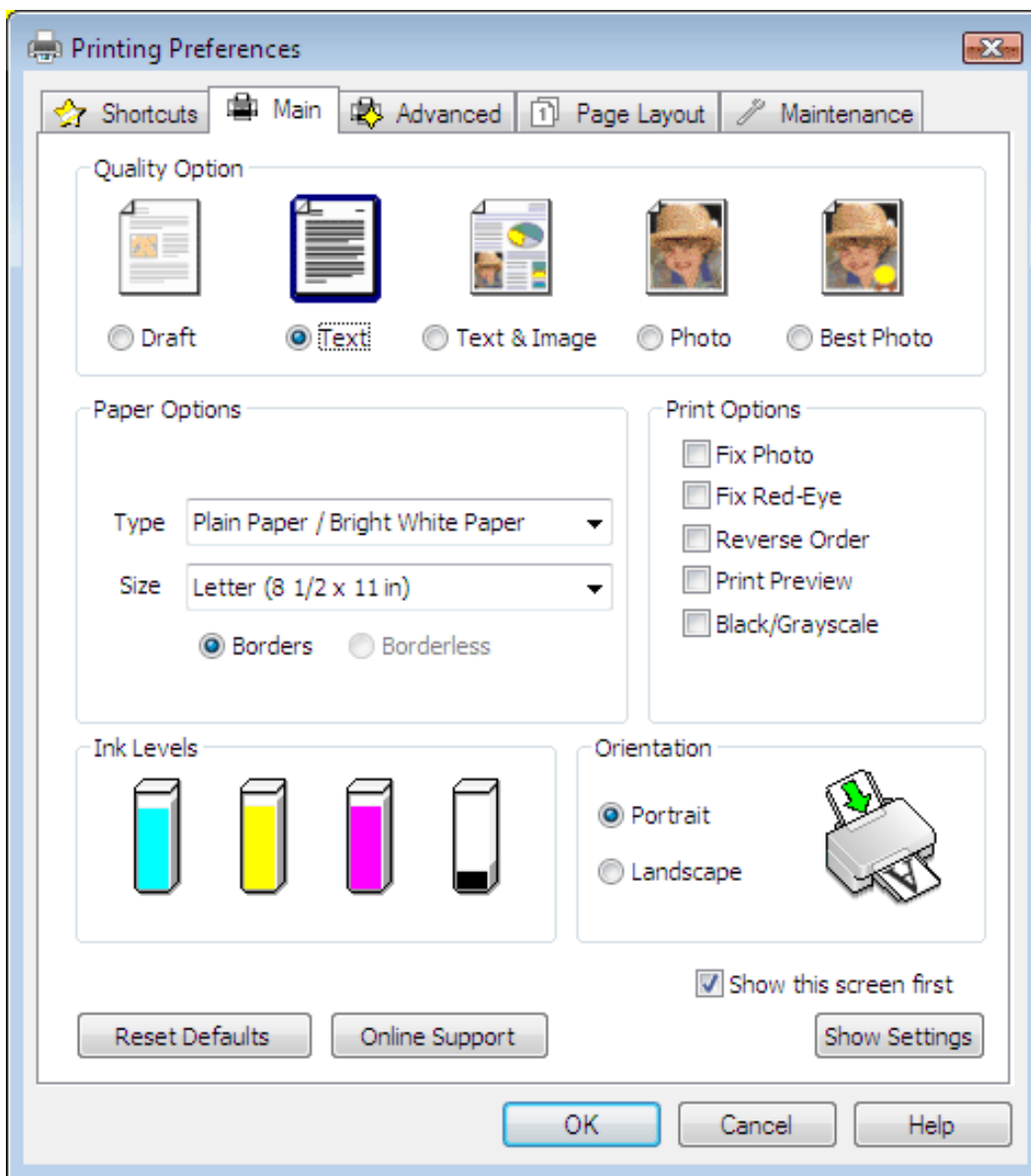

- 2 Click the **Main** tab, then select one of the following Quality Option settings:
 - **Draft** for rough drafts with reduced print quality
 - **Text** for text-only pages
 - **Text & Image** for higher quality pages with text and images
 - **Photo** for good quality and speed
 - **Best Photo** for the best print quality
- 3 Select the appropriate Type setting.
 [Selecting the Correct Paper Type](#)
- 4 Select the appropriate Size setting.
- 5 Select **Portrait** (tall) or **Landscape** (wide) to change the orientation of your printout.
- 6 Click the **Page Layout** tab and select **On** from 2-sided printing. Then click the **Folded Booklet** check box.

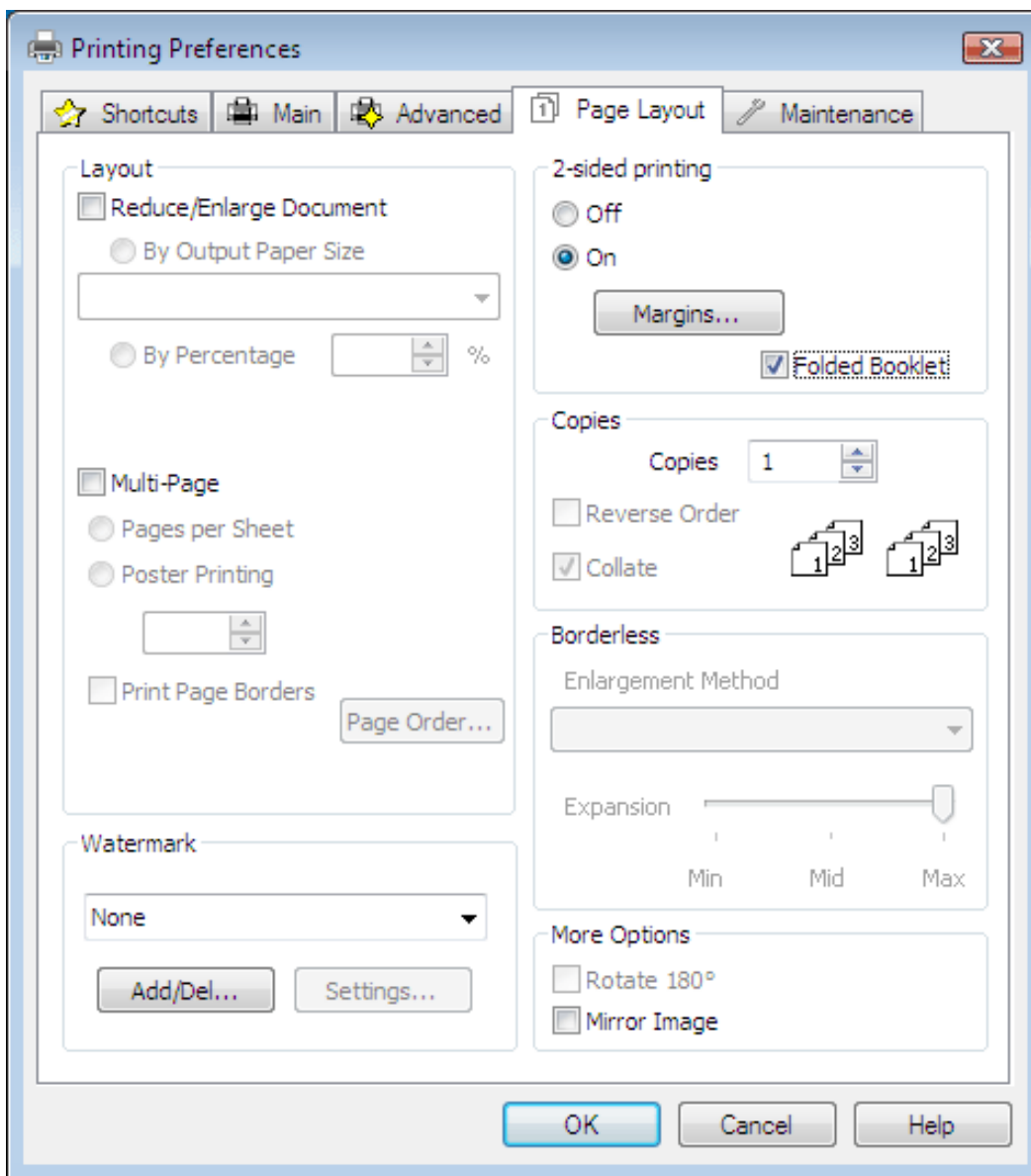

7 Click **Margins** to open the Margins window.

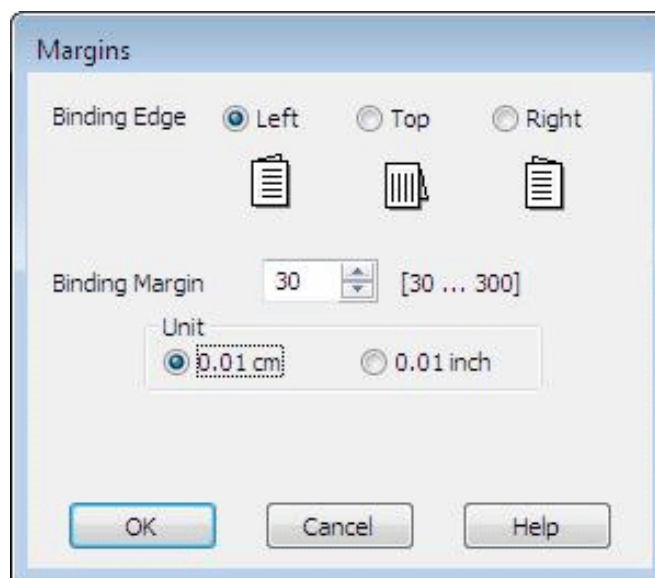

8 Specify the edge of the paper where the binding will be placed. You can choose **Left**, **Top**, or **Right**.

 **Note:**

When you select **Portrait** as the Orientation setting, the **Left** or **Right** binding positions are available. The **Top** binding position is available when you select **Landscape** as the Orientation setting.

9 Choose **cm** or **inch** as the Unit setting. Specify the width of the binding margin.

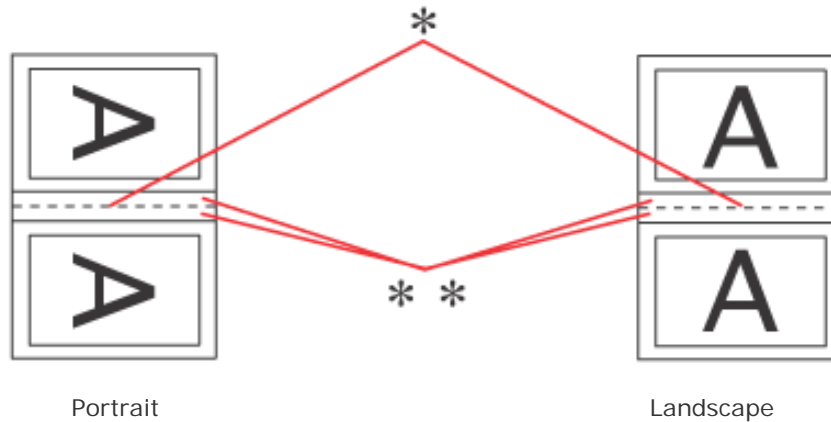

* : Folding edge
** : Margin

You can enter any width from 0.3 cm to 3.0 cm, or from 0.12 inches to 1.18 inches. The specified margin width will be used on both sides of the fold. For example, if you specify a 1 cm margin, you will get a 2 cm margin (a margin of 1 cm will be placed on each side of the fold).

10 Click **OK** to return to the Page Layout window. Then click **OK** to save your settings.

11 Load paper into the sheet feeder, then send the print job from your application. Instructions for printing the inside pages will be displayed while the outside pages are printed.

 **Loading Paper**

12 Follow the on-screen instructions to reload the paper.

 **Note:**

- - The paper may curl during printing due to the amount of ink used. Should this occur, slightly curl the sheets in the opposite direction before reloading them.
- - Align the sheet stack by tapping its edges against a hard, flat surface before reloading it in the printer.
- - Follow the instructions provided when reloading the printouts. Otherwise, paper may jam or the binding margins may be incorrect.
- - If a paper jam occurs, refer to the following.



See [The Paper Jams](#)

- 13 Once the paper is reloaded, click **Resume** to print the inside pages.
- 14 Once printing is complete, fold the sheets and bind them together using a stapler or other binding method.

[Home](#) > [How to Print](#)

Fit to Page Printing

[Printer Settings for Windows](#)[Printer Settings for Mac OS X 10.5.x](#)

You can use the Fit to Page printing function when you want to print, for example, an A4 size document on another size paper.

Fit to Page printing automatically resizes your page to the paper size you select. You can also resize your page manually.

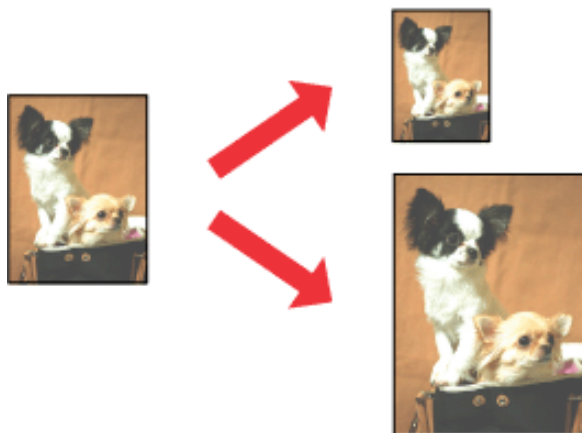

Note:

This feature is not available with borderless printing.

Note for Mac OS X users:

This is a standard feature of Mac OS X 10.4.x or later. To use this feature, make sure to select a standard paper size (for example, **A4**) as the Paper Size setting and the Scale to fit paper size setting. Do not select a paper size with a page setup option (for example, **Borderless**). This feature is not available for Mac OS X 10.3.9.

Printer Settings for Windows

1 Access the printer settings.

 [Accessing the Printer Driver for Windows](#)

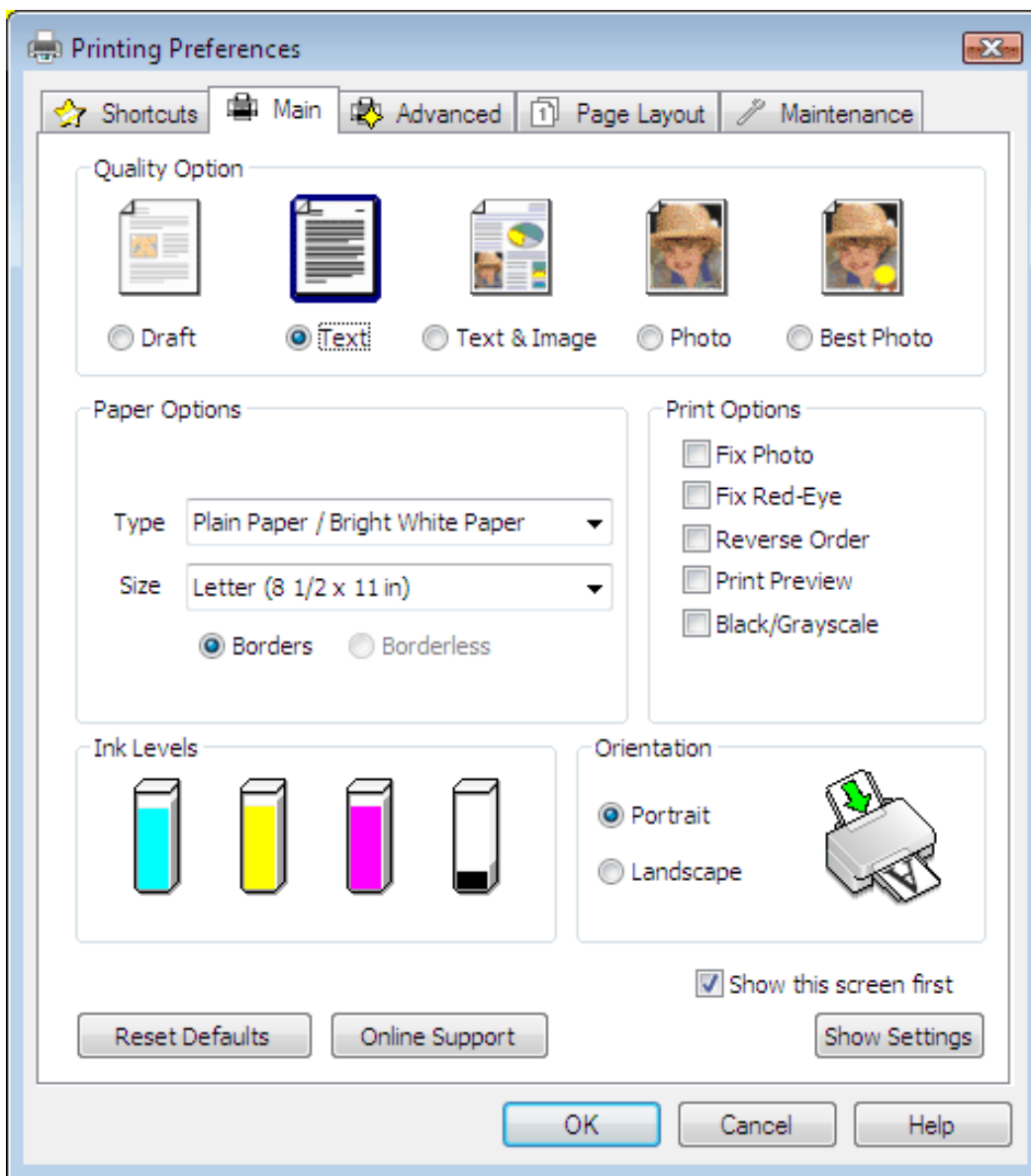

- 2 Click the **Main** tab, then select one of the following Quality Option settings:
 - **Draft** for rough drafts with reduced print quality
 - **Text** for text-only pages
 - **Text & Image** for higher quality pages with text and images
 - **Photo** for good quality and speed
 - **Best Photo** for the best print quality
- 3 Select the appropriate Type setting.
 [Selecting the Correct Paper Type](#)
- 4 Select the appropriate Size setting.
- 5 Select **Portrait** (tall) or **Landscape** (wide) to change the orientation of your printout.
- 6 Click the **Page Layout** tab, then select the **Reduce/Enlarge Document** check box.

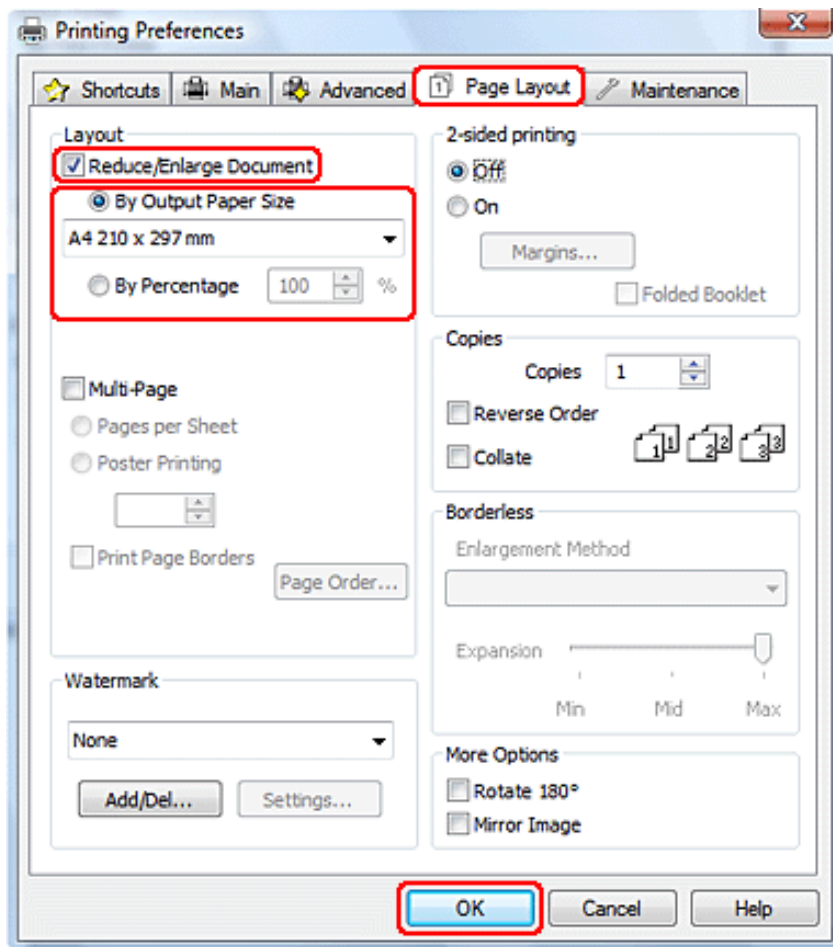

- 7 Do one of the following:
 - If you selected **By Output Paper Size**, select the size of the paper you are using from the drop-down list.
 - If you selected **By Percentage**, use the arrows to choose a percentage.
- 8 Click **OK** to close the printer settings window.

After completing the steps above, print one test copy and examine the results before printing an entire job.

[Top](#)

Printer Settings for Mac OS X 10.5.x

- 1 Access the Print dialog box.

[Accessing the Printer Driver for Mac OS X](#)

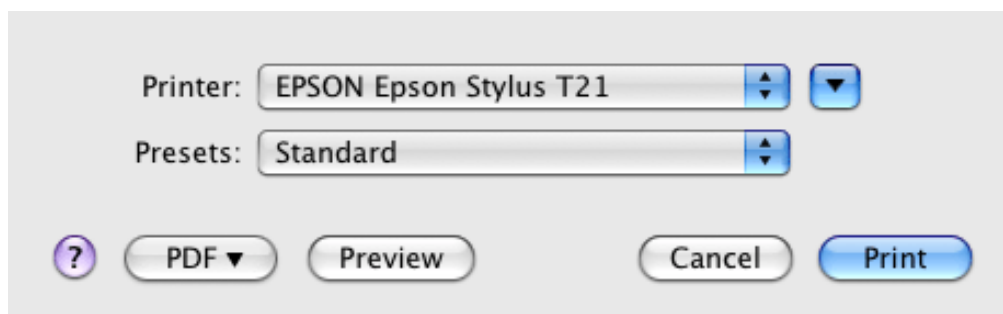

- 2 Click the ▼ button to extend this dialog box.
- 3 Select the printer you are using as the Printer setting, and then make suitable settings.

Printer: EPSON Epson Stylus T21

Presets: Standard

Copies: 1 Collated

Pages: All
 From: 1 to: 1

Paper Size: US Letter 8.50 by 11.00 inches

Orientation: Portrait Landscape Scale: 100 %

Preview

Automatically rotate each page

No automatic page scaling
 Scale each page to fit paper
 Only scale down large pages

Cancel Print

Note:

Depending on your application, you may not be able to select some of the items in this dialog box. If so, click **Page Setup** on the File menu of your application, and then make suitable settings.

- 4 Select **Paper Handling** from the pop-up menu.



Printer: EPSON Epson Stylus T21

Presets: Standard

Copies: 1 Collated

Pages: All
 From: 1 to: 1

Paper Size: US Letter 8.50 by 11.00 inches

Orientation:   Scale: 100 %

Paper Handling

Pages To Print: All pages

Destination Paper Size: Suggested Paper: US Letter
 Scale to fit paper size
 Scale down only

Page Order: Automatic

Cancel Print

- 5 Select the **Scale to fit paper size**.
- 6 Make sure that the appropriate size is displayed in Destination Paper Size.
- 7 Select **Print Settings** from the pop-up menu.

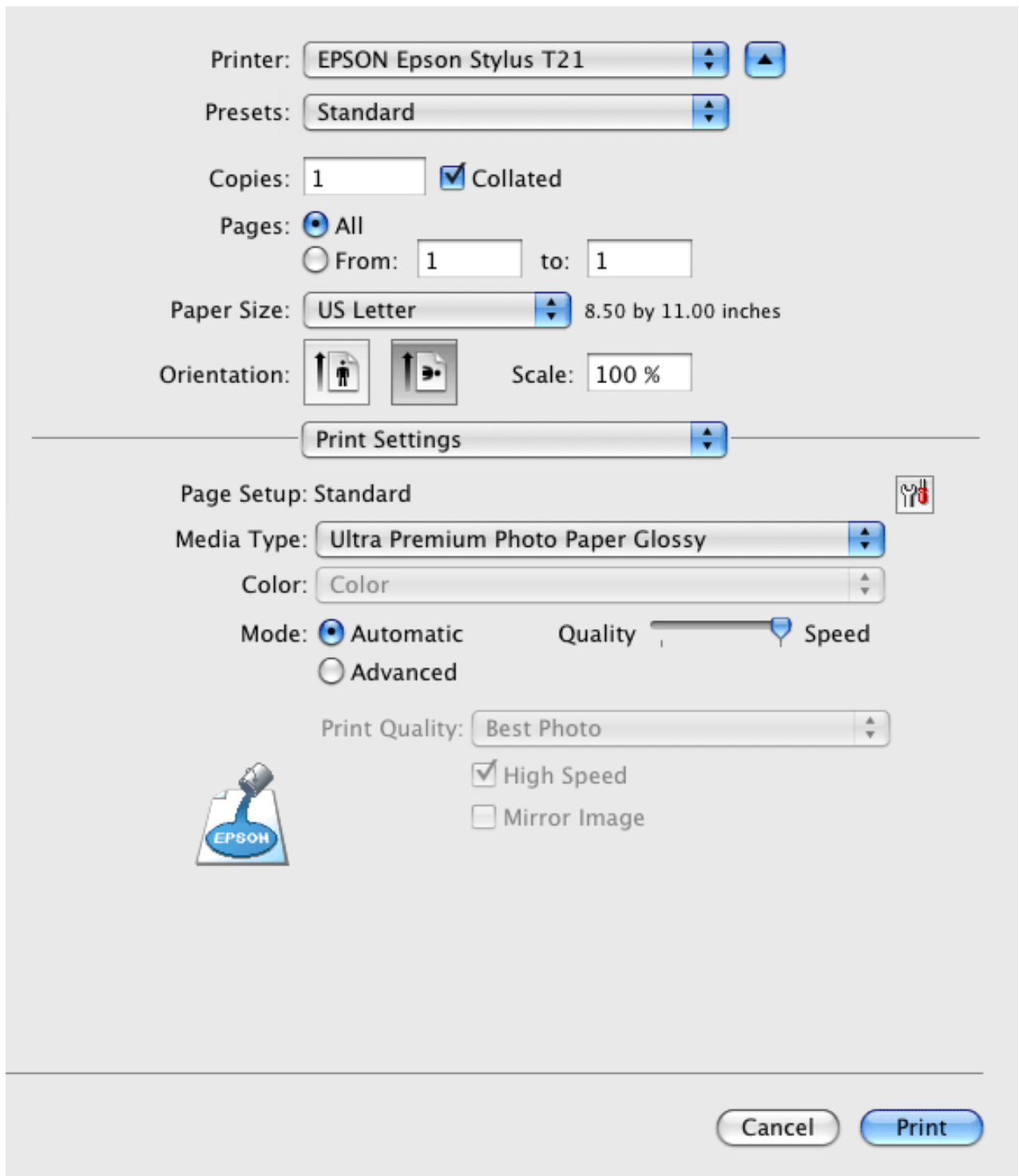

8 Make the settings that you want to use to print. See online help for details of Print Settings.

[Selecting the Correct Paper Type](#)

After completing the steps above, print one test copy and examine the results before printing an entire job.

[Home](#) > [How to Print](#)

Pages Per Sheet Printing

- [Printer Settings for Windows](#)
- [Printer Settings for Mac OS X 10.5.x](#)
- [Printer Settings for Mac OS X 10.3.9 to 10.4.x](#)

Pages Per Sheet printing allows you to print two or four pages on single sheets of paper.

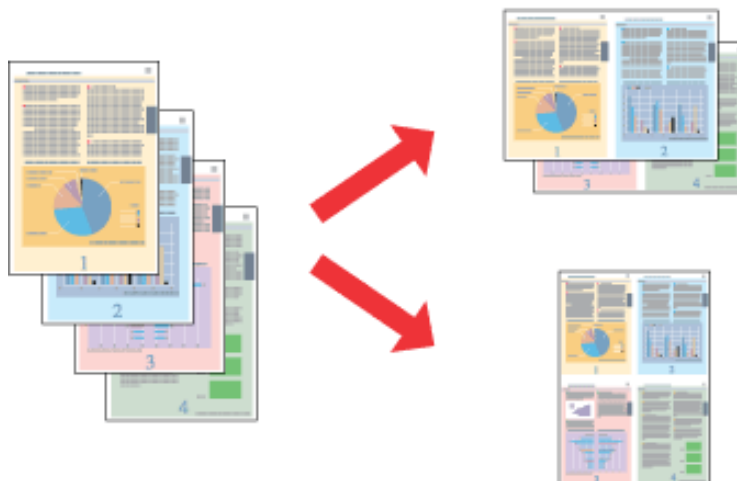

 **Note:**

This feature is not available with borderless printing.

Printer Settings for Windows

- 1 Access the printer settings.

 [Accessing the Printer Driver for Windows](#)

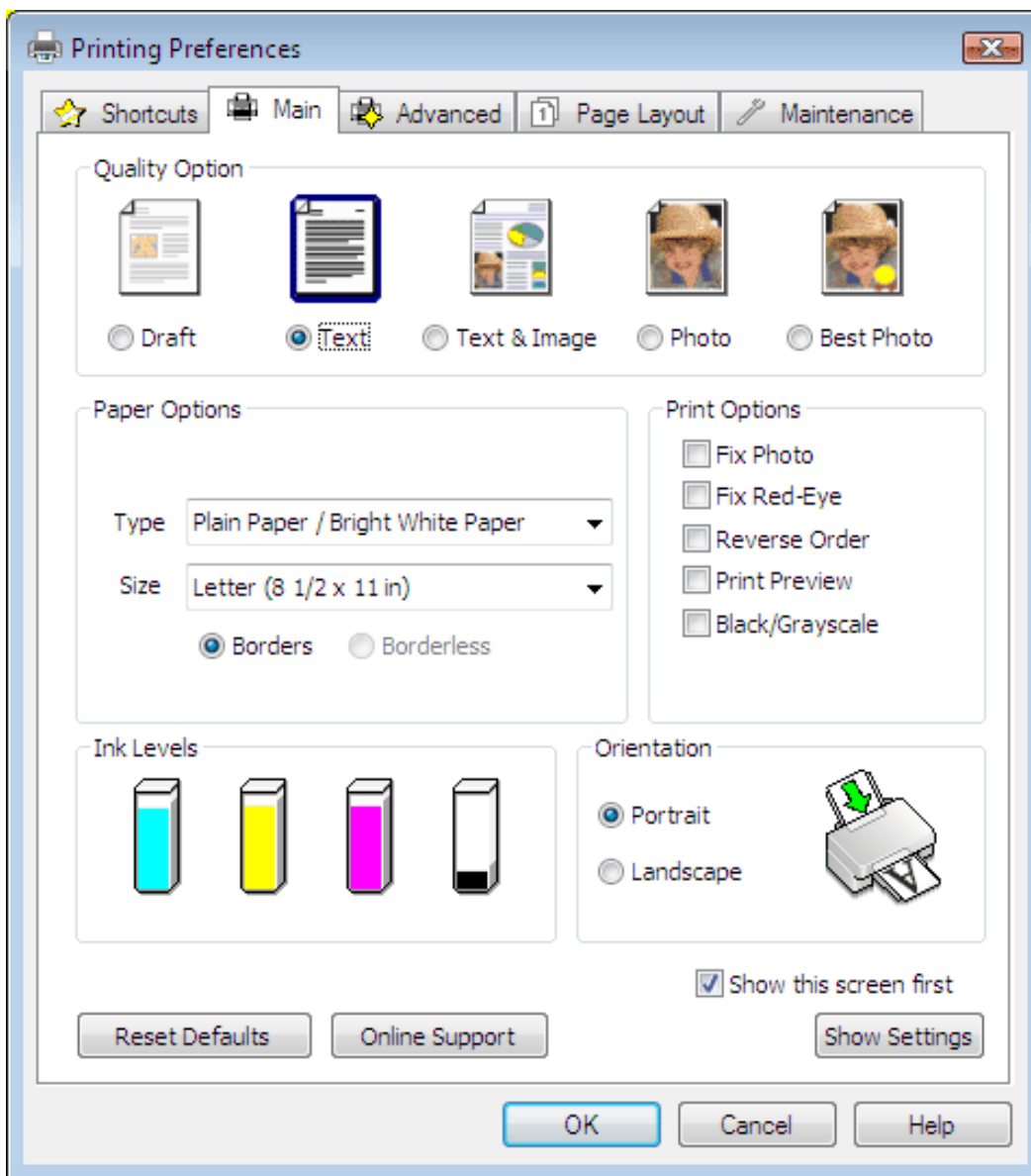

- 2 Click the **Main** tab, then select one of the following Quality Option settings:
 - **Draft** for rough drafts with reduced print quality
 - **Text** for text-only pages
 - **Text & Image** for higher quality pages with text and images
 - **Photo** for good quality and speed
 - **Best Photo** for the best print quality
- 3 Select the appropriate Type setting.
 - 🖨️ [Selecting the Correct Paper Type](#)
- 4 Select the appropriate Size setting.
- 5 Select **Portrait** (tall) or **Landscape** (wide) to change the orientation of your printout.
- 6 Click the **Page Layout** tab, select **Multi-Page**, then select **Pages per Sheet**.

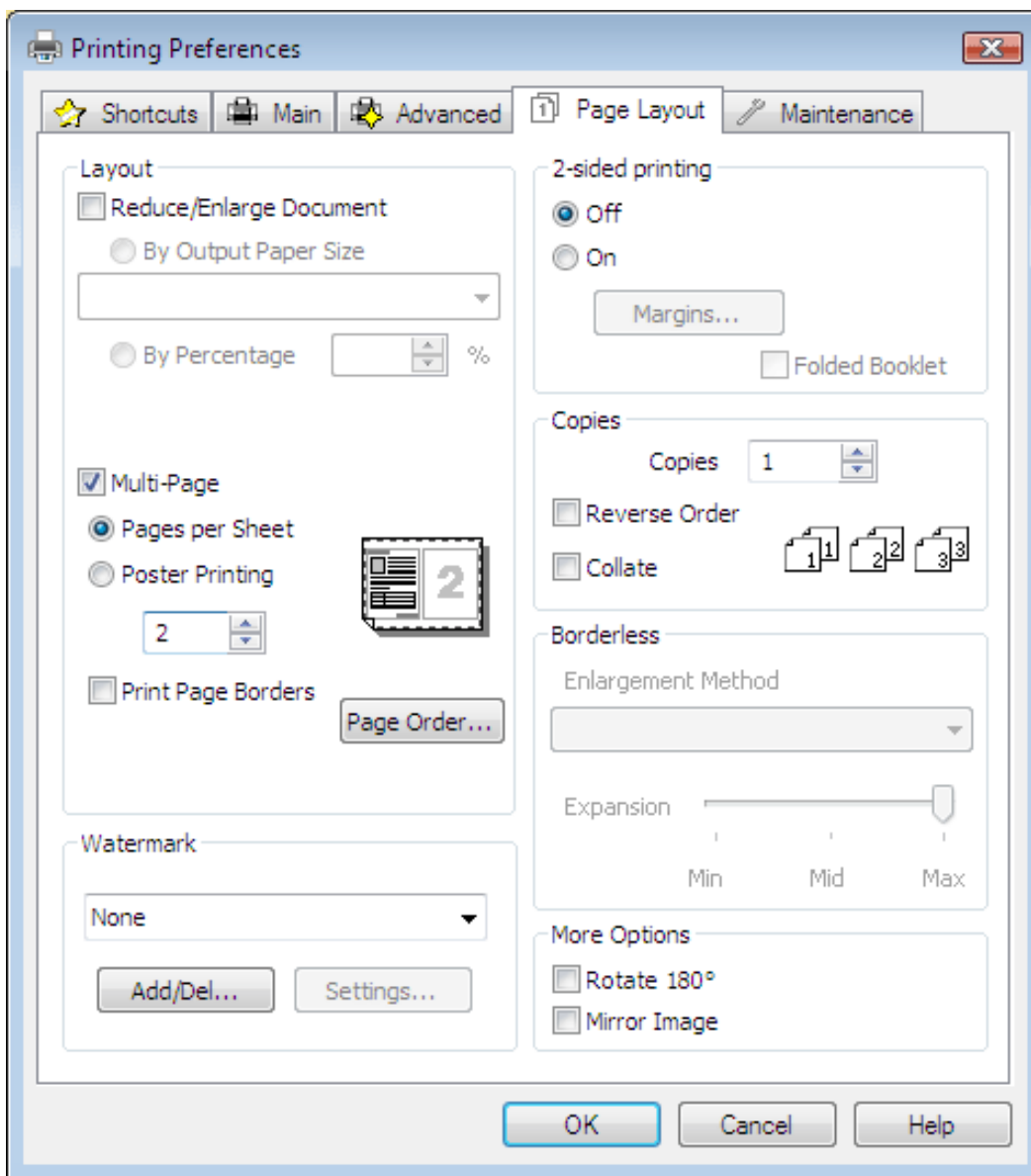

7 Select from the following settings for Pages Per Sheet printing:

2, 4	Prints two or four pages of your document on a single piece of paper.
Print Page Borders	Prints frames around the pages printed on each sheet.
Page Order	Allows you to specify the order in which the pages will be printed on the sheet of paper. Some settings may be unavailable, depending on the Orientation setting on the Main window.

8 Click **OK** to close the printer settings window.

After completing the steps above, print one test copy and examine the results before printing an entire job.

[Top](#)

- 1 Access the Print dialog box.

 Accessing the Printer Driver for Mac OS X

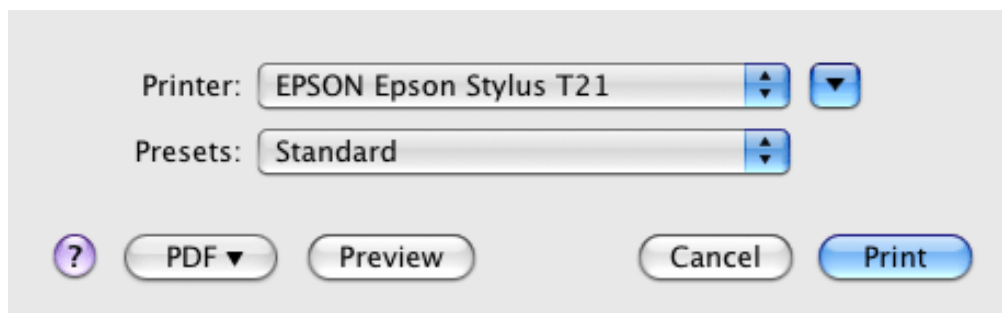

- 2 Click the ▼ button to extend this dialog box.

- 3 Select the printer you are using as the Printer setting, and then make suitable settings.

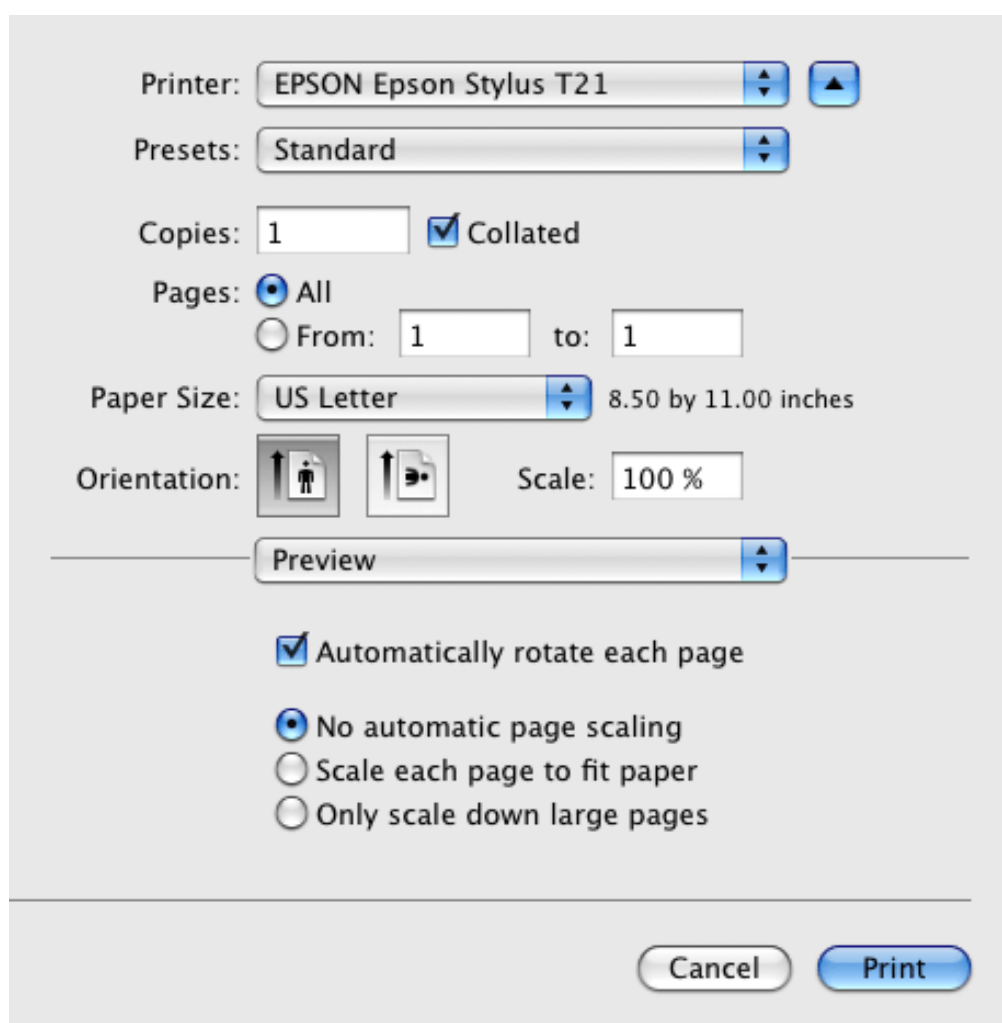

 **Note:**

Depending on your application, you may not be able to select some of the items in this dialog box. If so, click **Page Setup** on the File menu of your application, and then make suitable settings.

4 Select **Layout** from the pop-up menu.

Printer: EPSON Epson Stylus T21

Presets: Standard

Copies: 1 Collated

Pages: All
 From: 1 to: 1

Paper Size: US Letter 8.50 by 11.00 inches

Orientation: Scale: 100 %

Layout

Pages per Sheet: 2

Layout Direction:

Border: None

Two-Sided: Off

Reverse Page Orientation

Cancel Print

5 Select from the following settings:

Pages per Sheet	Prints multiple pages of your document on a single piece of paper. You can choose from 1, 2, 4, 6, 9, or 16 .
Layout Direction	Allows you to specify the order in which the pages will be printed on the sheet of paper.
Border	Prints a border around the pages printed on each sheet. You can choose from None, Single Hairline, Single Thin Line, Double Hairline, or Double Thin Line .

6 Select **Print Settings** from the pop-up menu.

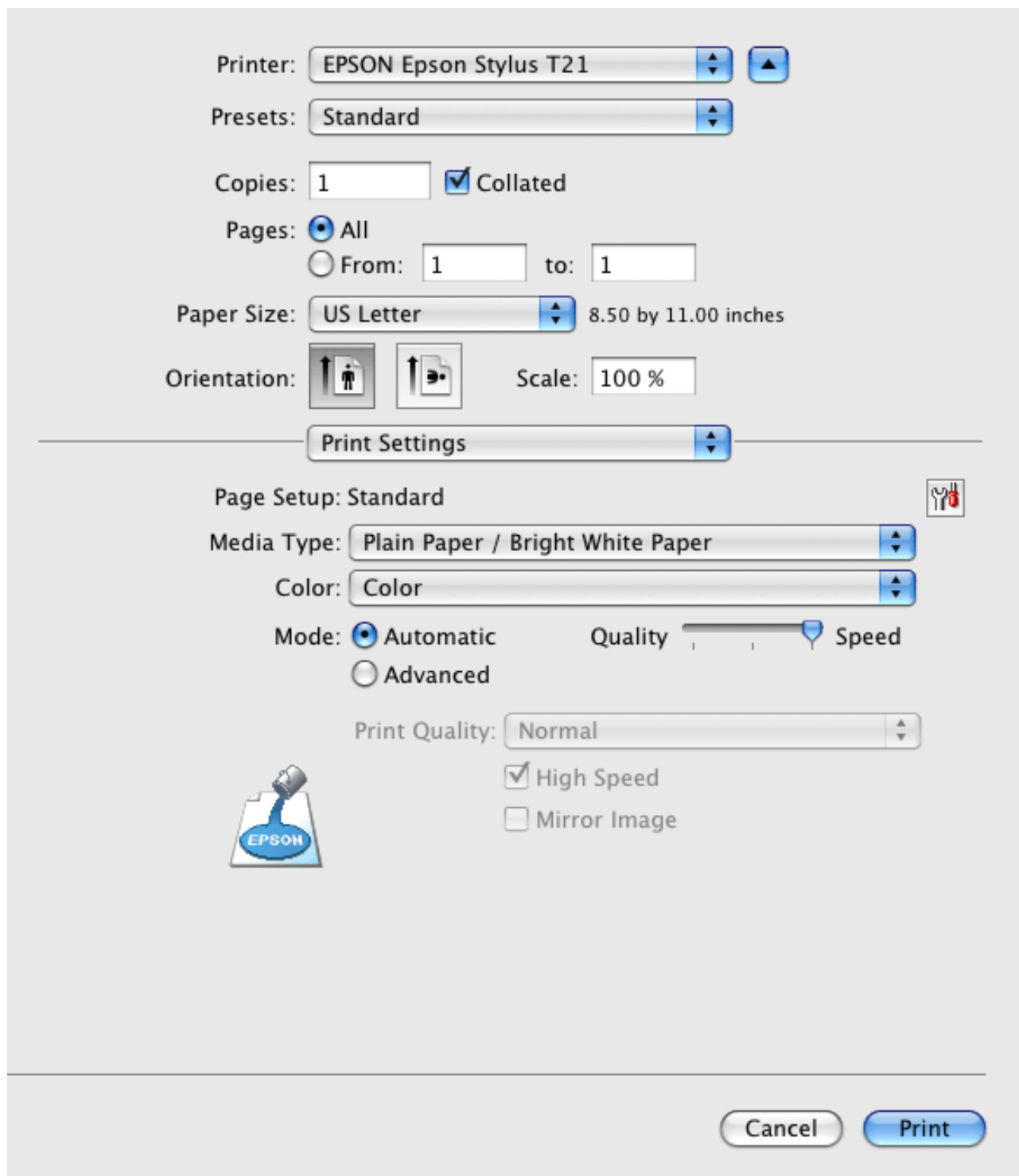

7 Make the settings that you want to use to print. See online help for details of Print Settings.

 [Selecting the Correct Paper Type](#)

After completing the steps above, print one test copy and examine the results before printing an entire job.

Top 

1 Access the Page Setup dialog box.

 [Accessing the Printer Driver for Mac OS X](#)

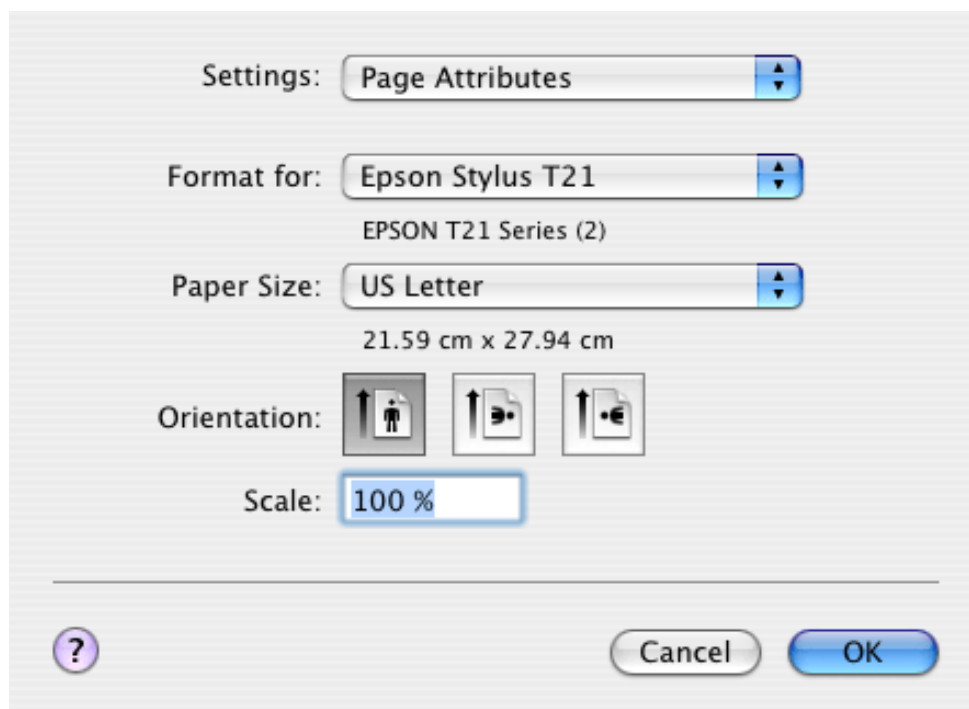

2 Select the printer you are using as the Format for setting.

3 Select the appropriate Paper Size and Orientation settings.

4 Click **OK** to close the Page Setup dialog box.

5 Access the Print dialog box.

 [Accessing the printer driver for Mac OS X](#)

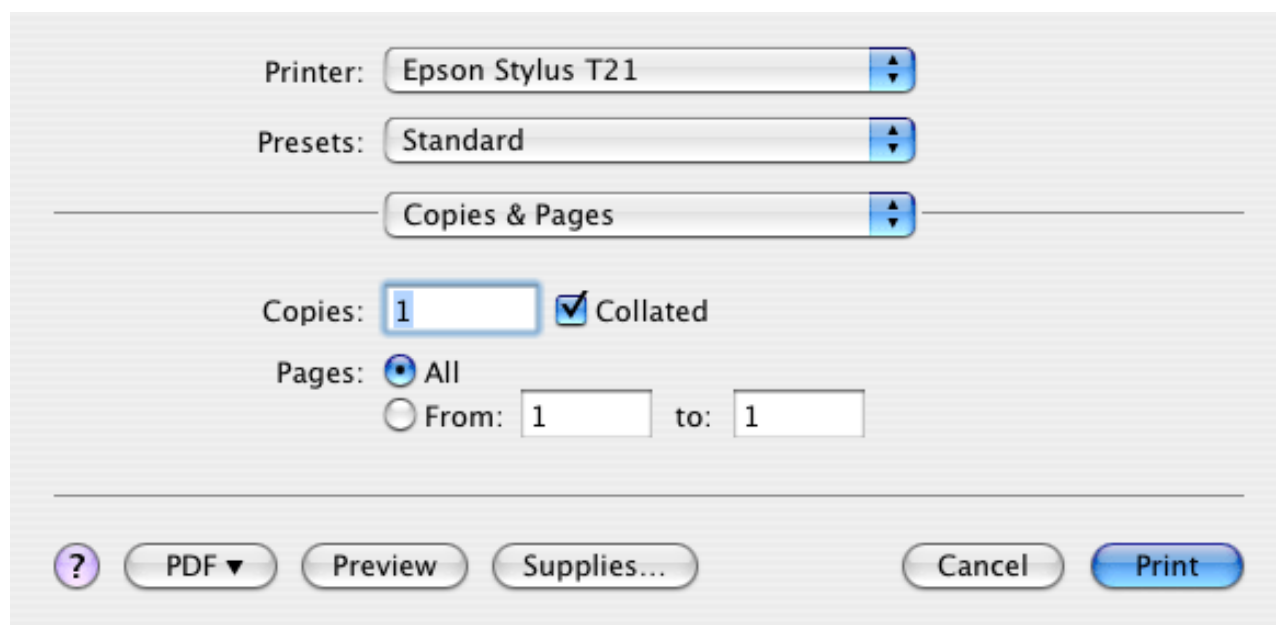

6 Select the printer you are using as the Printer setting, then make the Copies & Pages settings.

7 Select **Layout** from the pop-up menu.

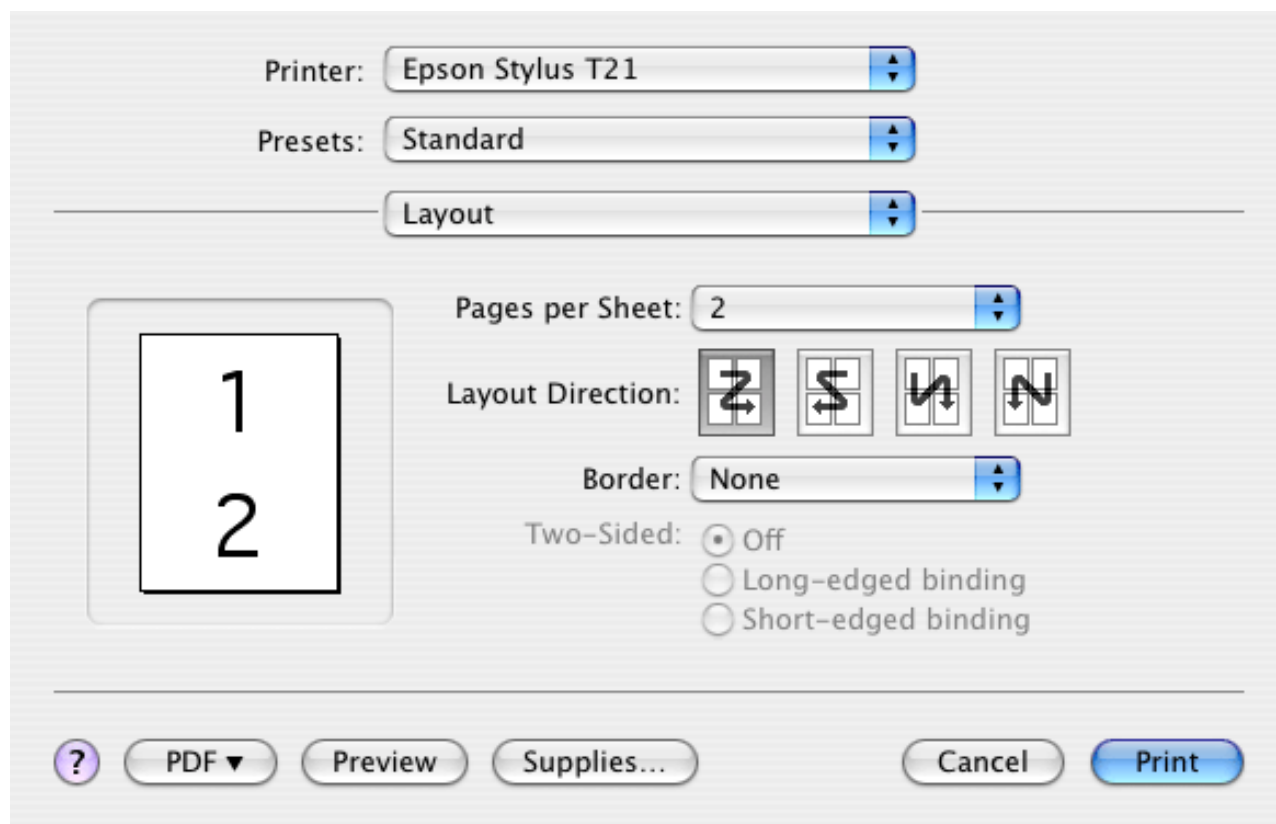

8 Select from the following settings:

Pages per Sheet	Prints multiple pages of your document on a single piece of paper. You can choose from 1, 2, 4, 6, 9, or 16 .
Layout Direction	Allows you to specify the order in which the pages will be printed on the sheet of paper.
Border	Prints a border around the pages printed on each sheet. You can choose from None, Single Hairline, Single Thin Line, Double Hairline, or Double Thin Line .

9 Select **Print Settings** from the pop-up menu.

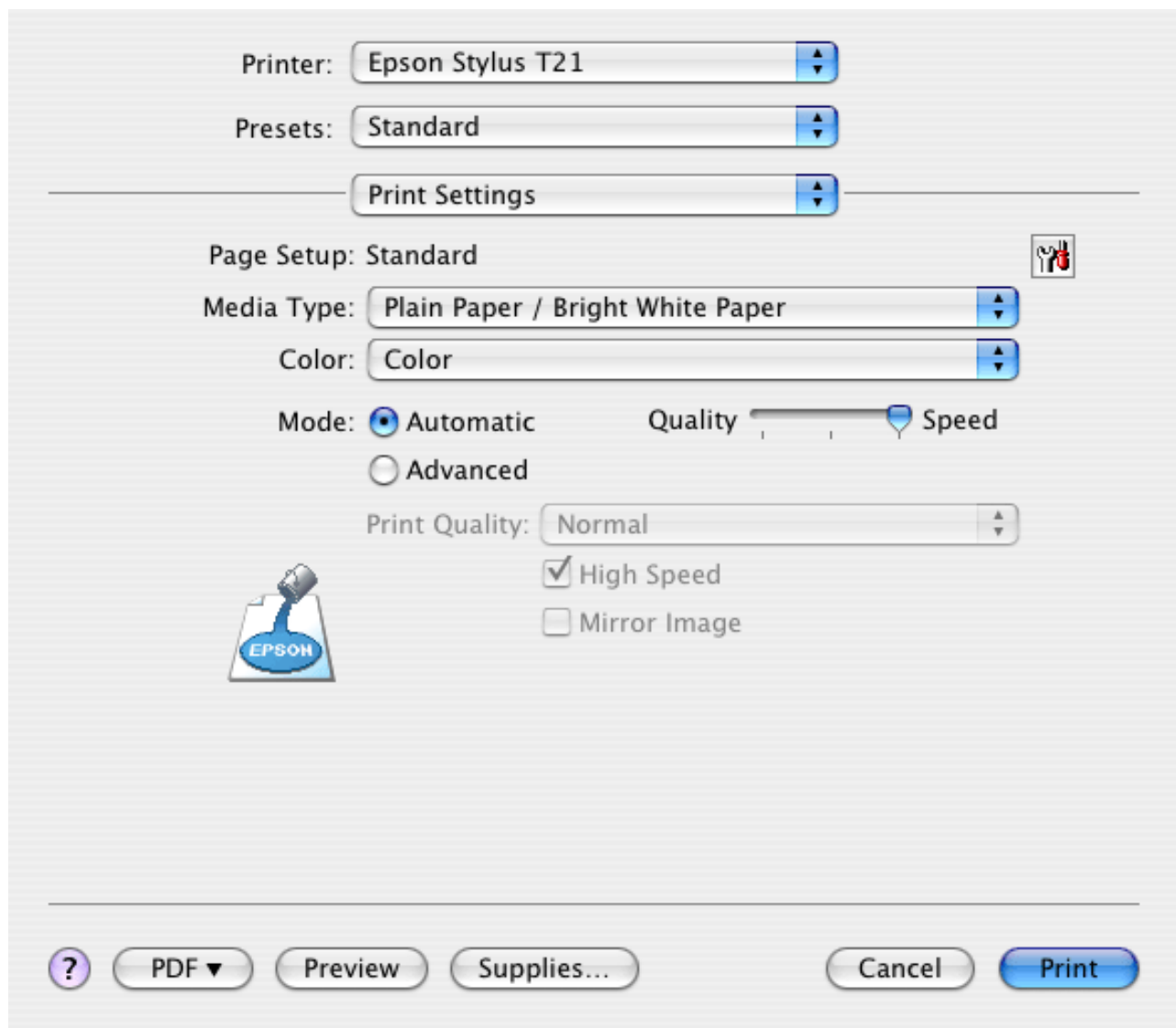

10 Select the appropriate Media Type, Color, and Mode settings. See the online help for details of **Print Settings**.

 [Selecting the Correct Paper Type](#)

After completing the steps above, print one test copy and examine the results before printing an entire job.

Top 

[Home](#) > [How to Print](#)

■ Poster Printing (Windows Only)

 [Printer Settings](#)

 [How to Make a Poster from Your Printouts](#)

Poster printing allows you to print poster-size images by enlarging one page to cover several sheets of paper.

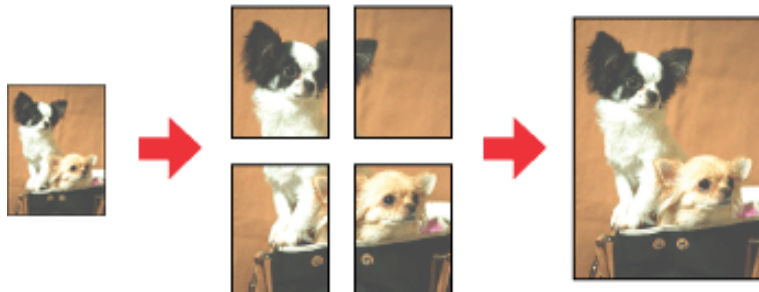

 **Note:**

This feature is not available for Mac OS X.

Printer Settings

1 Access the printer settings.

 [Accessing the Printer Driver for Windows](#)

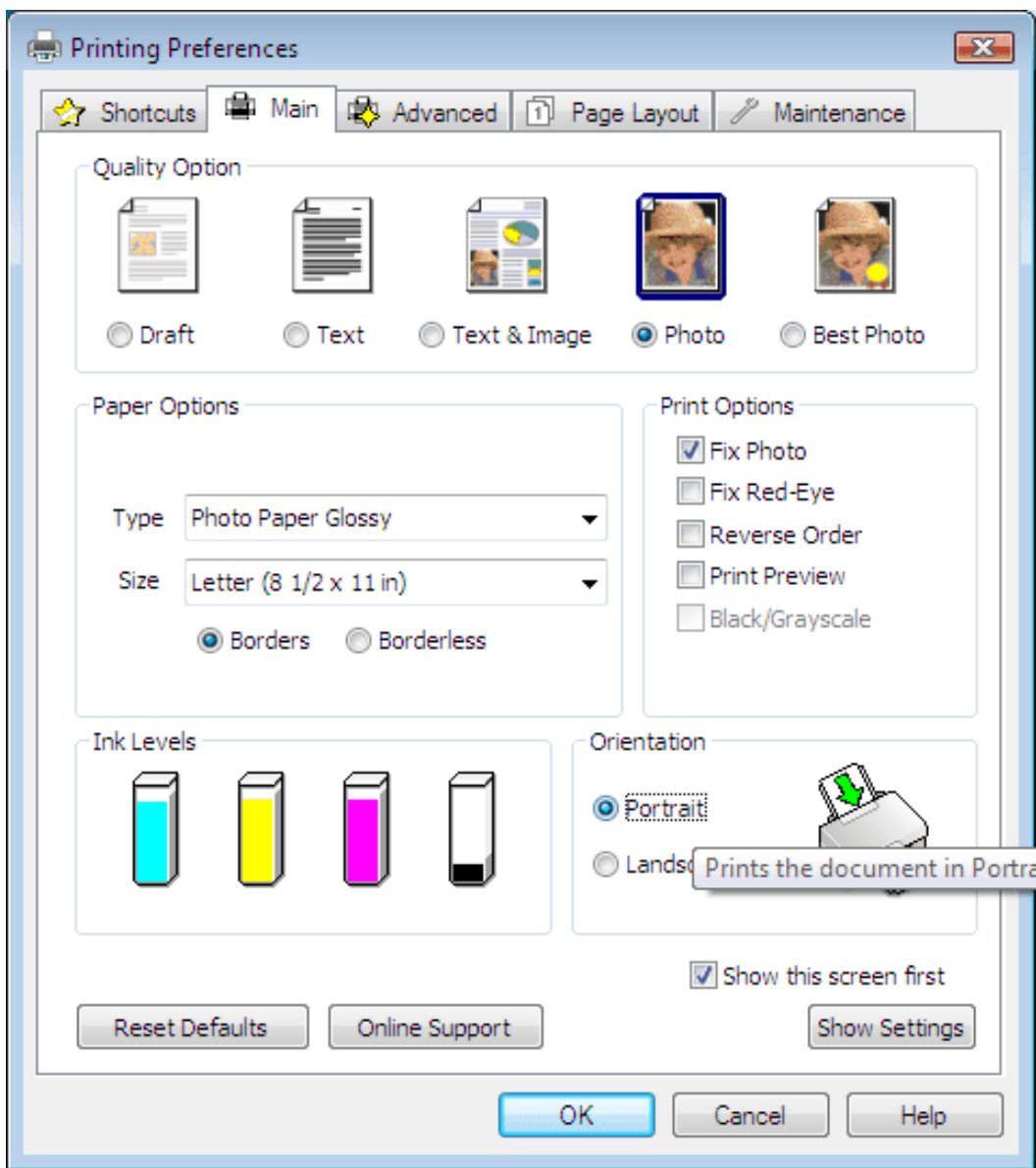

- 2 Click the **Main** tab, then select one of the following Quality Option settings:
 - **Draft** for rough drafts with reduced print quality
 - **Text** for text-only documents
 - **Text & Image** for higher quality pages with text and images
 - **Photo** for good quality and speed
 - **Best Photo** for the best print quality
- 3 Select the appropriate Type setting.
 - 🖨️ [Selecting the Correct Paper Type](#)
- 4 Select the appropriate Size setting.
- 5 Select **Portrait** (tall) or **Landscape** (wide) to change the orientation of your printout.
- 6 Click the **Page Layout** tab and select **Multi-Page**, then select **Poster Printing**. Click the up or down arrow to select **2x1**, **2x2**, **3x3**, or **4x4**.

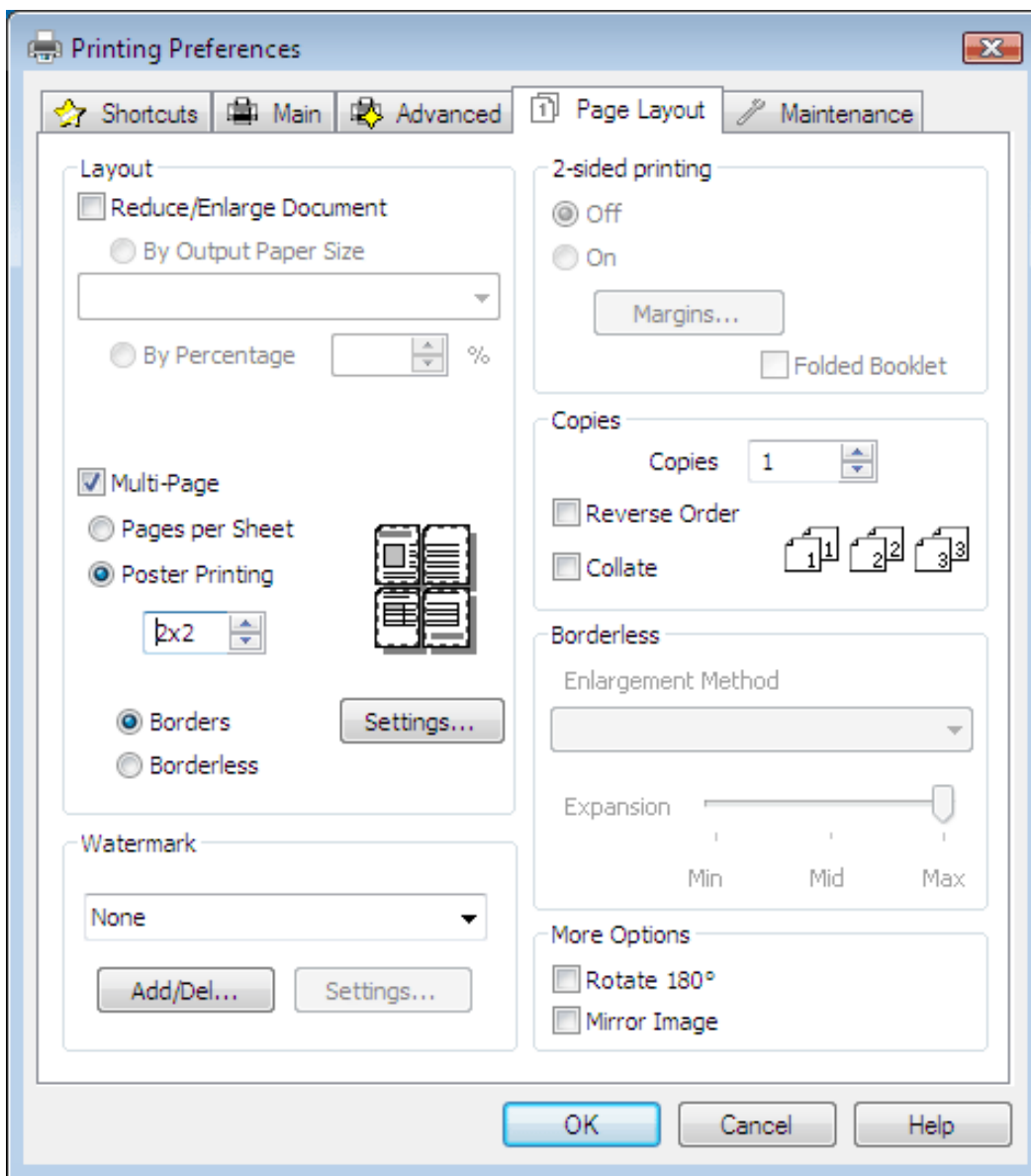

7 Select **Borders** or **Borderless** according to the following table.

Borders	Prints panels with margins to be cut and overlapped.
Borderless	Allows you to make posters without cutting the margins and overlapping the panels.

If you want to control the amount of the image that extends beyond the edges of the paper, click the **Page Layout** tab, select **Auto Expand** as the Enlargement Method, and then adjust the **Expansion** slider.

8 Click **Settings** to adjust the way your poster will be printed. The Poster Settings window opens.

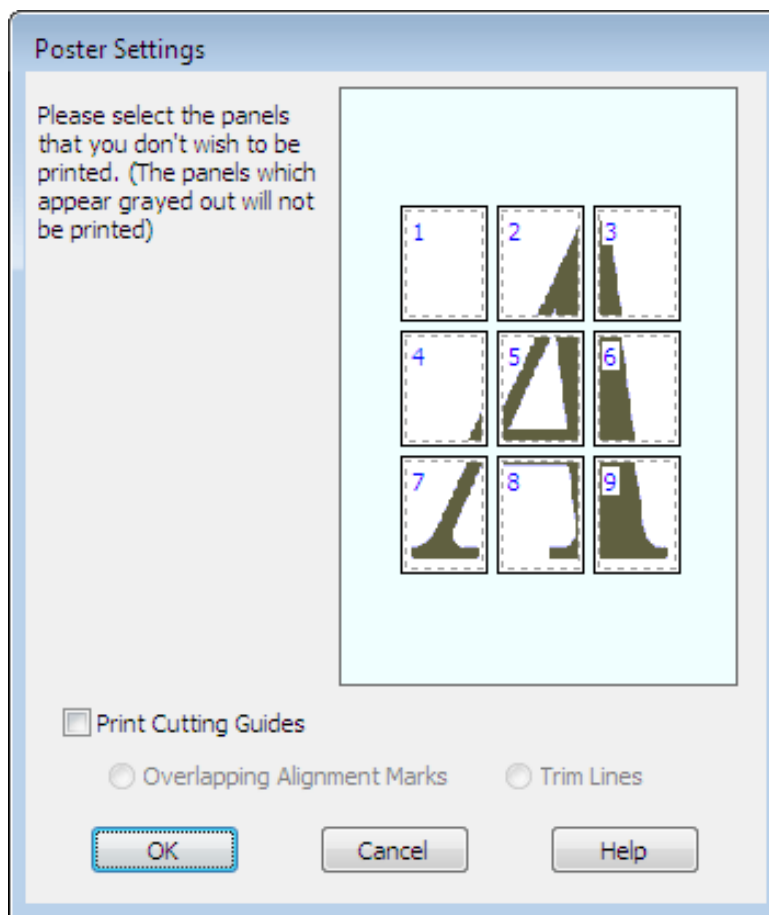

9 Make the following settings:

Print Cutting Guides	Prints guide lines for cutting.
Overlapping Alignment Marks	Slightly overlaps the panels and prints alignment markers so that the panels can be aligned more precisely.
Trim Lines	Prints border lines on the panels to guide you when trimming the pages.

 **Note:**

- - If you select **Borderless** in step 7, the message "The poster prints will be borderless." appears on the window and the settings in the table above are not available.
- - If you want to print only a few of the panels without printing the entire poster, click the panels that you do not want to print.

10 Click **OK** to close the Poster Settings window.

After completing the steps above, print one test copy and examine the results before printing an entire job. Then follow the instructions.

 [How to make a poster from your printouts](#)

How to Make a Poster from Your Printouts

Here is an example of how to make a poster with **2x2** selected under Poster Printing and **Overlapping Alignment Marks** selected as the Print Cutting Guides.

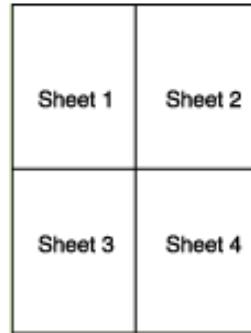

- 1 Cut off the margin of Sheet 1 along a vertical line through the center of the top and bottom cross marks:

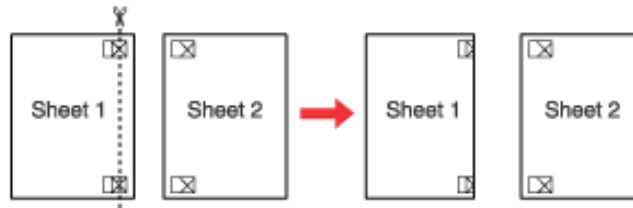

- 2 Place the edge of Sheet 1 on top of Sheet 2 and align the cross marks, then temporarily tape the two sheets together from the back:

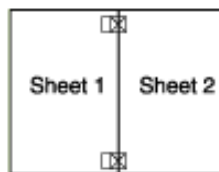

- 3 Cut the taped sheets in two along a vertical line through the alignment markers (this time, a line to the left of the cross marks):

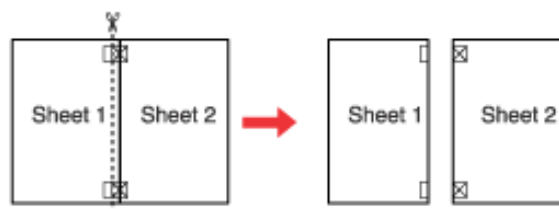

- 4 Align the edges of the paper using the alignment markers and tape them together from the back:

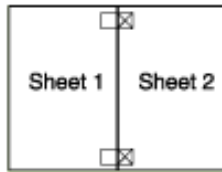

- 5 Repeat the instructions from step 1 to step 4 to tape Sheets 3 and 4 together.
- 6 Repeat the instructions from step 1 to step 4 to tape the top and bottom edges of the paper:

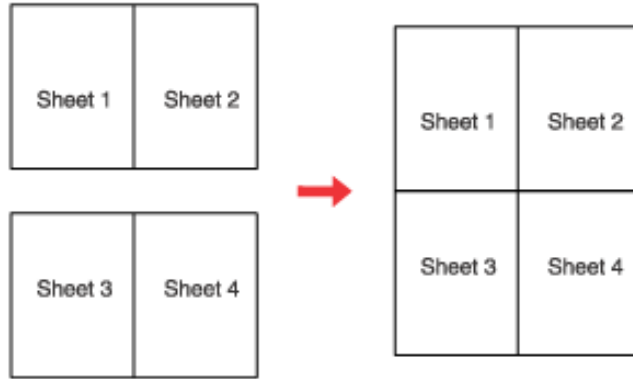

- 7 Cut off the remaining margins.

[Home](#) > [How to Print](#)

■ Watermark Printing (For Windows Only)

 [Printing the Watermark](#)

 [Creating Your Own Watermark](#)

Watermark printing allows you to print a text-based or image-based watermark on your document.



Note:

- This feature is not available for Mac OS X.
- This feature is not available with borderless printing.

Printing the Watermark

1 Access the printer settings.



[Accessing the Printer Driver for Windows](#)

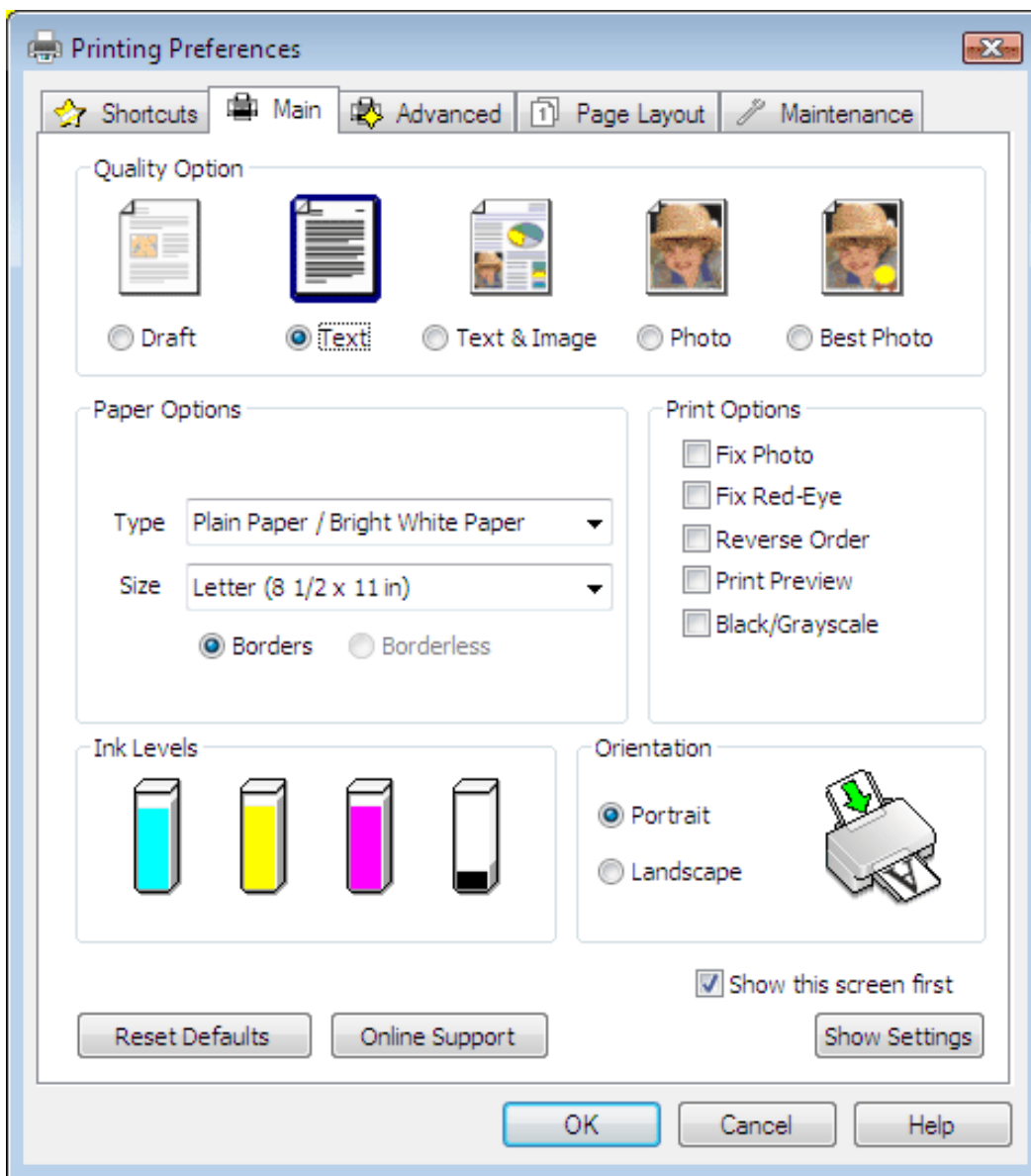

- 2 Click the **Main** tab, then select one of the following Quality Option settings:
 - **Draft** for rough drafts with reduced print quality
 - **Text** for text-only documents with higher text quality
 - **Text & Image** for higher quality documents with text and images
- 3 Select the appropriate Type setting.
 -  [Selecting the Correct Paper Type](#)
- 4 Select the appropriate Size setting.
- 5 Select **Portrait** (tall) or **Landscape** (wide) to change the orientation of your printout.
- 6 Click the **Page Layout** tab, choose the desired watermark from the Watermark list, then click **Settings**.

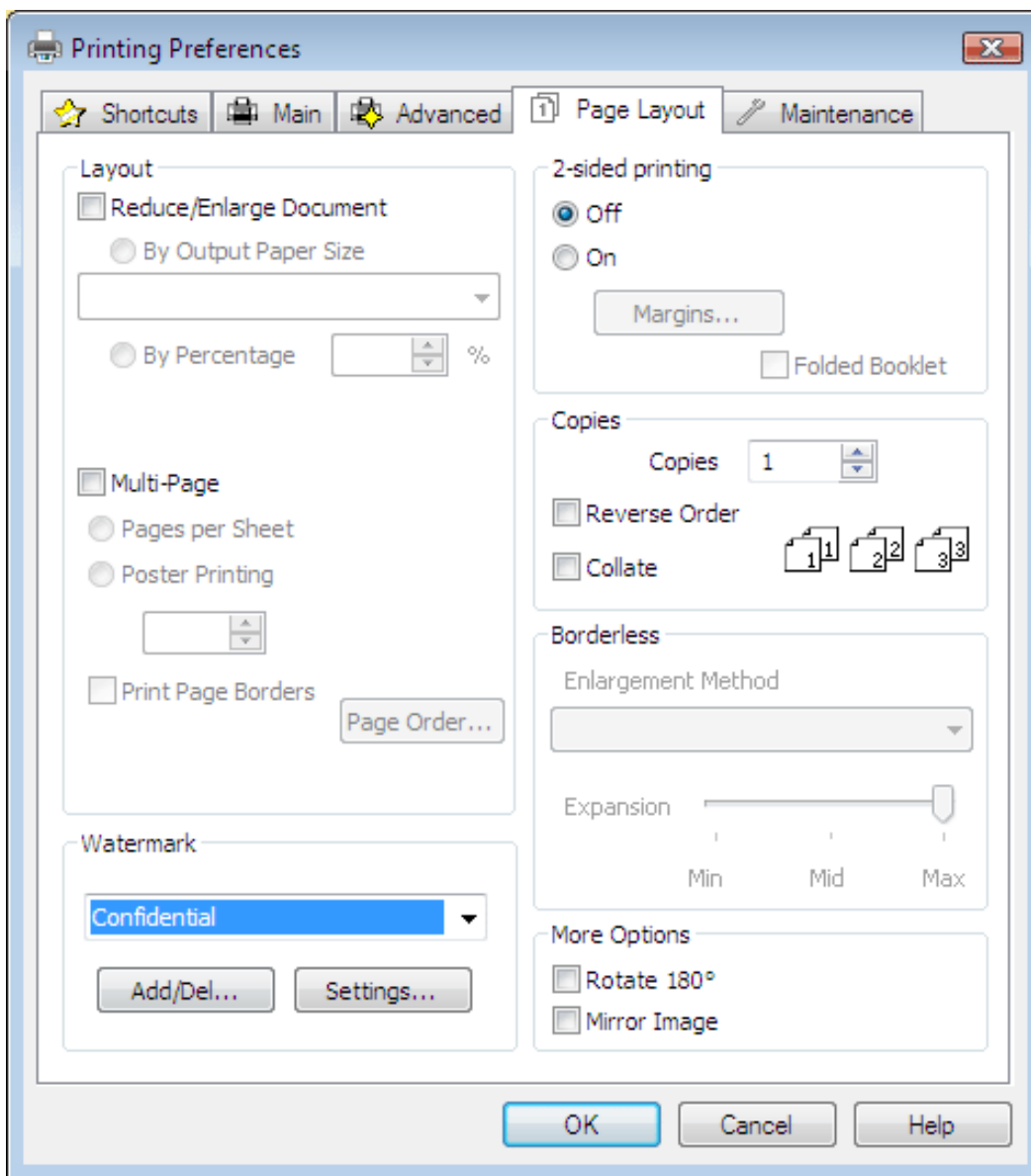

If you want to create your own watermark, see the following instructions.

Creating your own watermark

- 7 Specify the settings you want for the watermark. You can change the position and size of the watermark by dragging the image within the preview window.

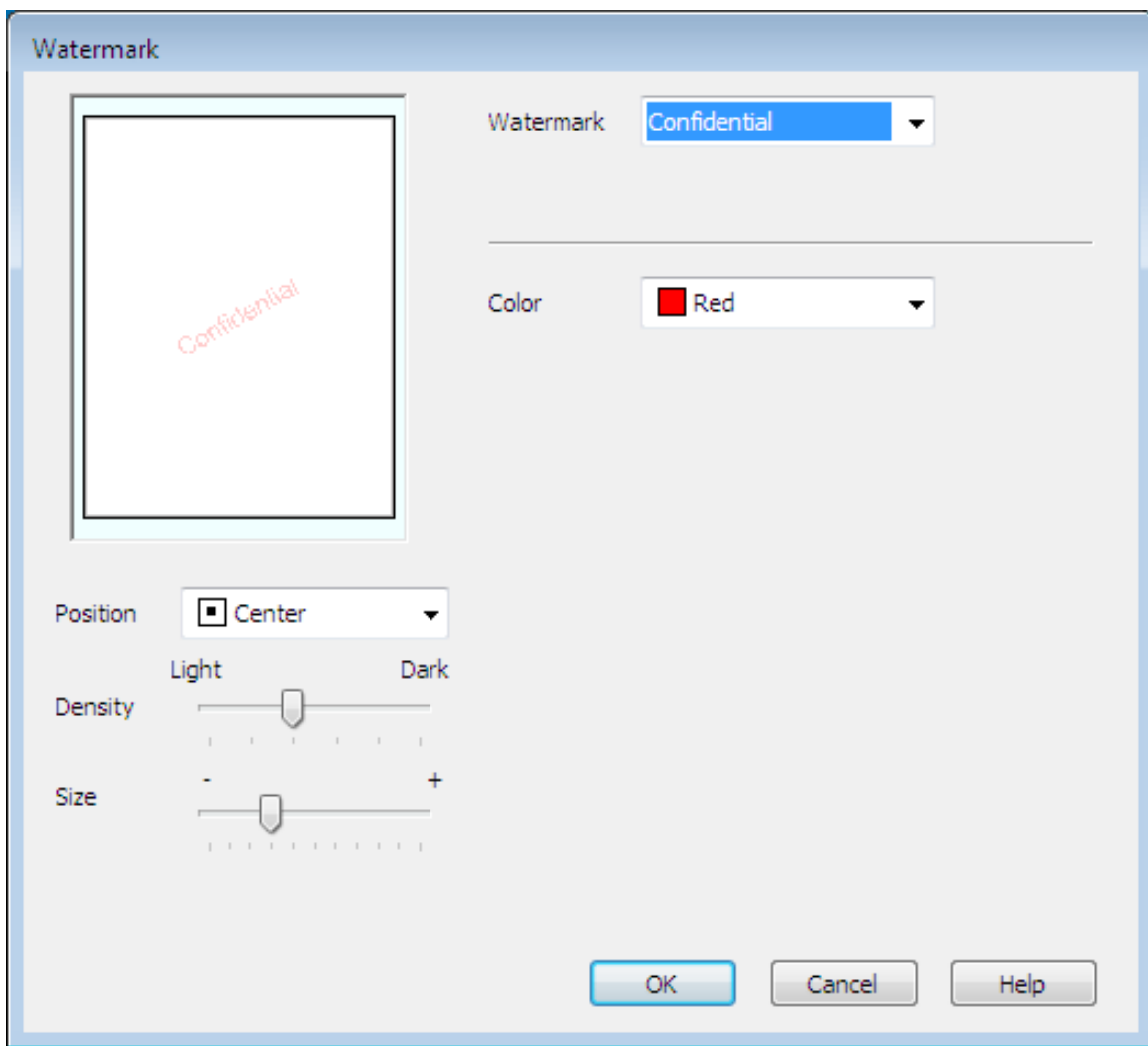

8 Click **OK** to return to the Page Layout window.

9 Click **OK** to close the printer settings window.

After completing the steps above, print one test copy and examine the results before printing an entire job.

[Top](#) 

Creating Your Own Watermark

You can add your own text-based or image-based watermarks to the Watermark list.

1 Click **Add/Del** under Watermark on the Page Layout window. The following window appears.

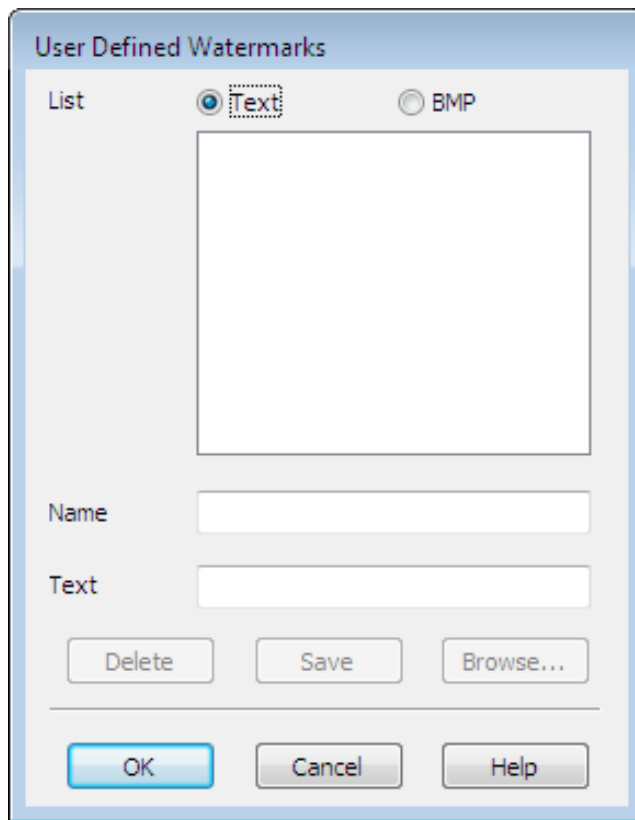

2 Do one of the following:

- To use an image file as a watermark, select **BMP**. Click **Browse** to locate the bitmap file you want to use, then click **OK**. Type a name for your watermark in the Name text box, then click **Save**.
- To create a text-based watermark, select **Text**. Type your text in the Text box. This text will also be used as the watermark name. If you want to change the watermark name, type a new name in the Name text box, then click **Save**.

3 Click **OK** to return to the Page Layout window.

4 Click **Settings**. The following window appears:

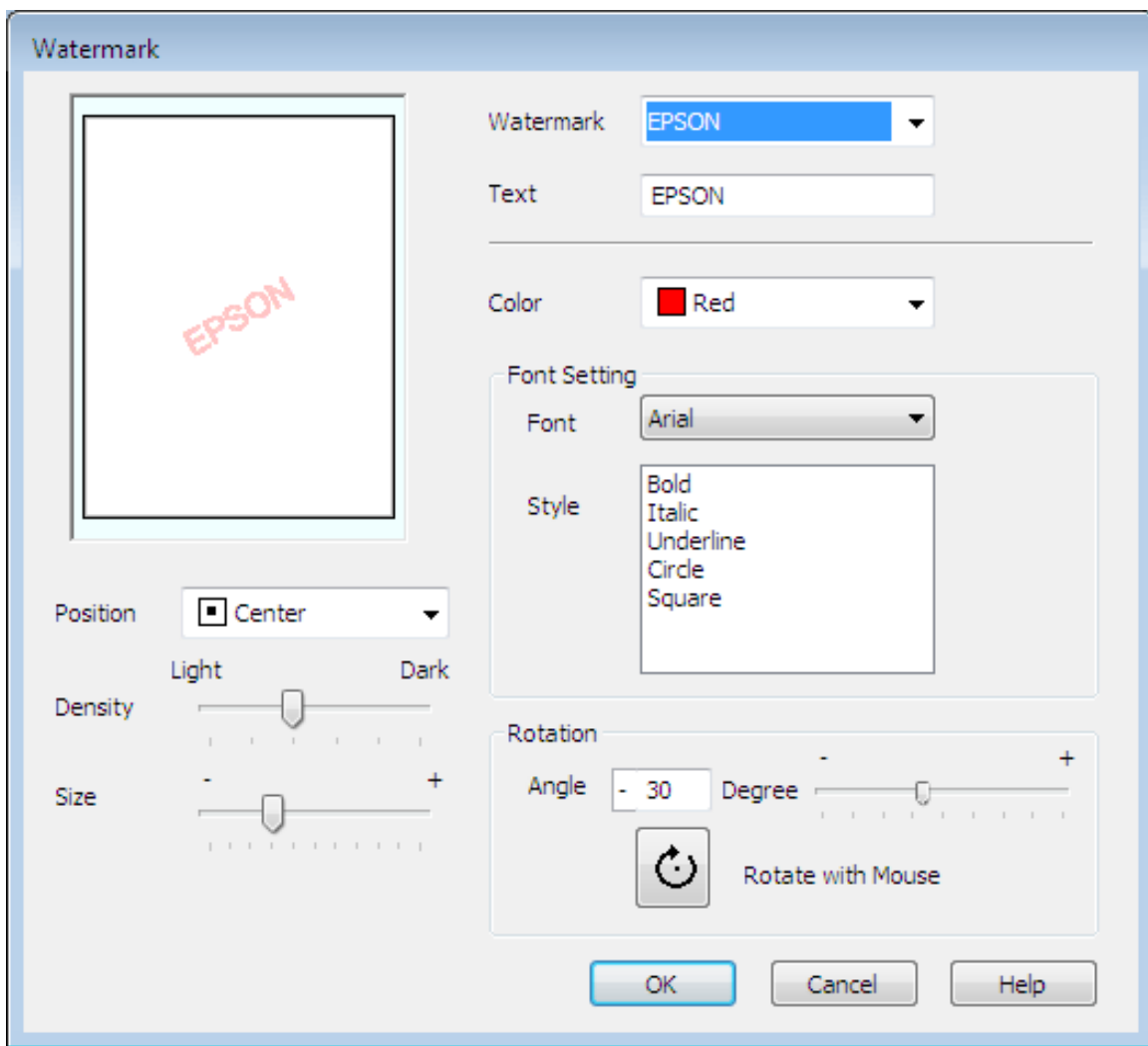

- 5 Make sure that the appropriate watermark is selected in the Watermark list, then select Color, Position, Density, Size, Font, Style, and Angle settings. (For details, see the online help.) Your settings are reflected in the preview window.
- 6 When you finish making settings, click **OK**.

[Home](#) > [Replacing Ink Cartridges](#)

■ Checking the Ink Cartridge Status

 [For Windows](#)

 [For Mac OS X](#)

For Windows

Note:

- - Epson cannot guarantee the quality or reliability of non-genuine ink. If non-genuine ink cartridges are installed, the ink cartridge status may not be displayed.
- - When an ink cartridge is running low, the Low Ink Reminder screen automatically appears. You can also check the ink cartridge status from this screen. If you do not want to display this screen, first access the printer driver and then click the **Maintenance** tab, **Speed & Progress**, and then **Monitoring Preferences**. On the Monitoring Preferences screen, clear the **Enable Low Ink Reminder** check box.

To check the ink cartridge status, do one of the following:

- Double-click the printer shortcut icon on your Windows taskbar. To add a shortcut icon to the taskbar, see the following section:
 -  See [From the Shortcut Icon on the Taskbar](#)
- Open the printer driver, click the **Maintenance** tab, then click the **EPSON Status Monitor 3** button. A graphic displays the ink cartridge status.

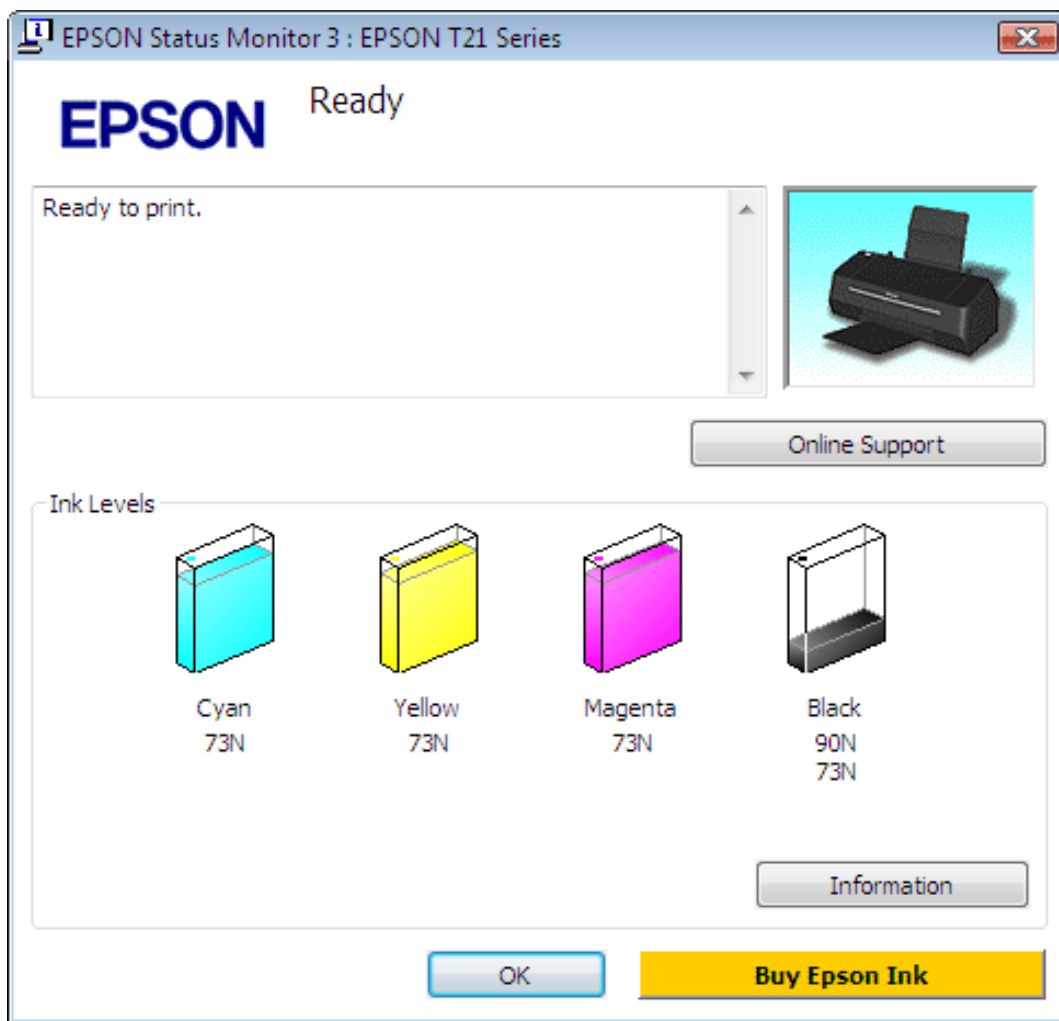

 **Note:**

If any of the ink cartridges installed in the printer is broken, incompatible with the printer model, or improperly installed, EPSON Status Monitor 3 will not display an accurate calculation of the ink cartridge status. Be sure to replace or reinstall any ink cartridge indicated by EPSON Status Monitor 3.

- The progress meter appears automatically when you start a print job. You can check the ink cartridge status from this window. Click the **Check Ink Levels** button on the progress meter screen to display the ink cartridge status as shown below.

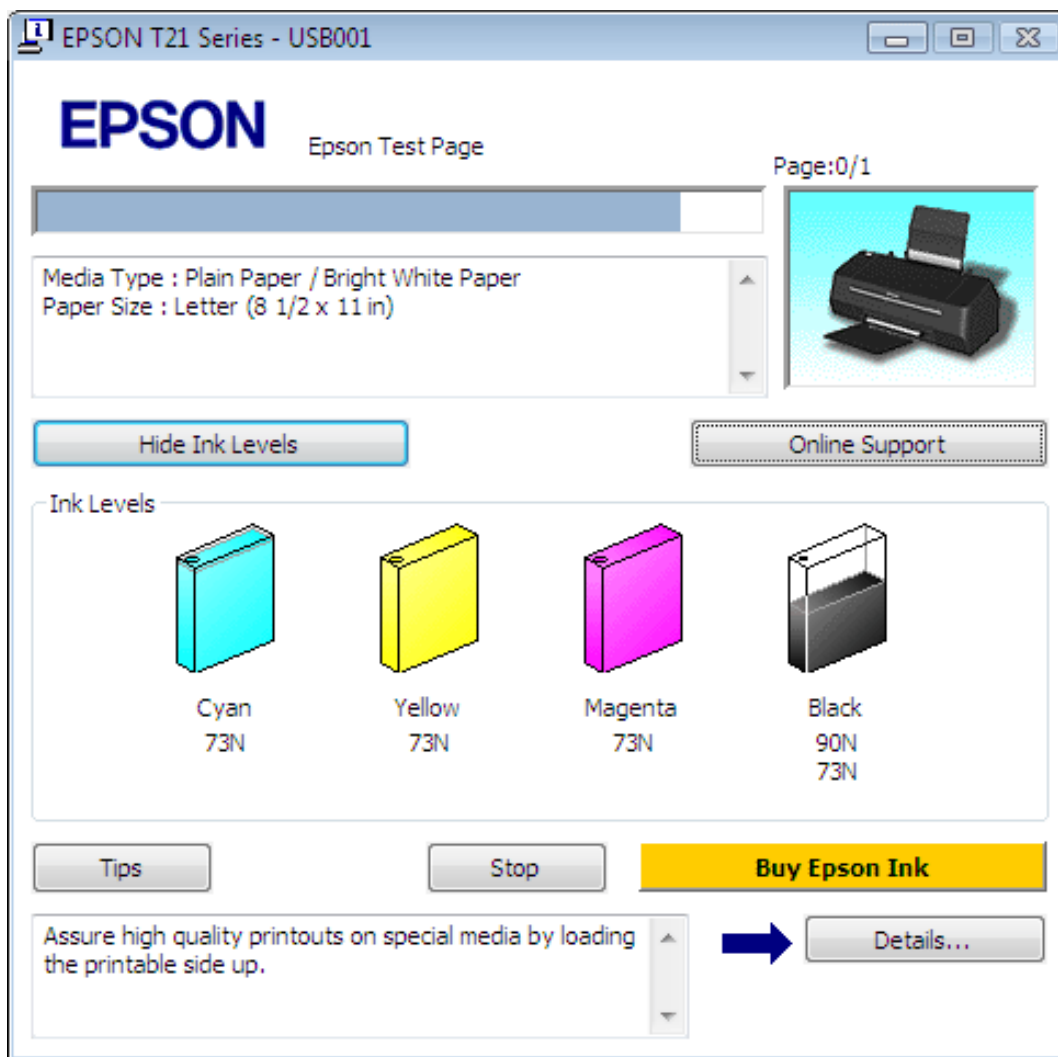

Top 

For Mac OS X

Note for Mac OS X 10.5.x

When an ink cartridge is running low, the Low Ink Reminder window automatically appears. You can also check the ink cartridge status from this window. If you do not want to display this window, select the **Preferences** menu from the Application menu when the Low Ink Reminder window is displayed, and then clear the **Enable Low Ink Reminder** check box.

You can check the ink cartridge status using EPSON StatusMonitor. Follow the steps below.

- 1 Access the EPSON Printer Utility3 dialog box.

 [Accessing the Printer Driver for Mac OS X](#)

- 2 Click the **EPSON StatusMonitor** button. The EPSON StatusMonitor appears.

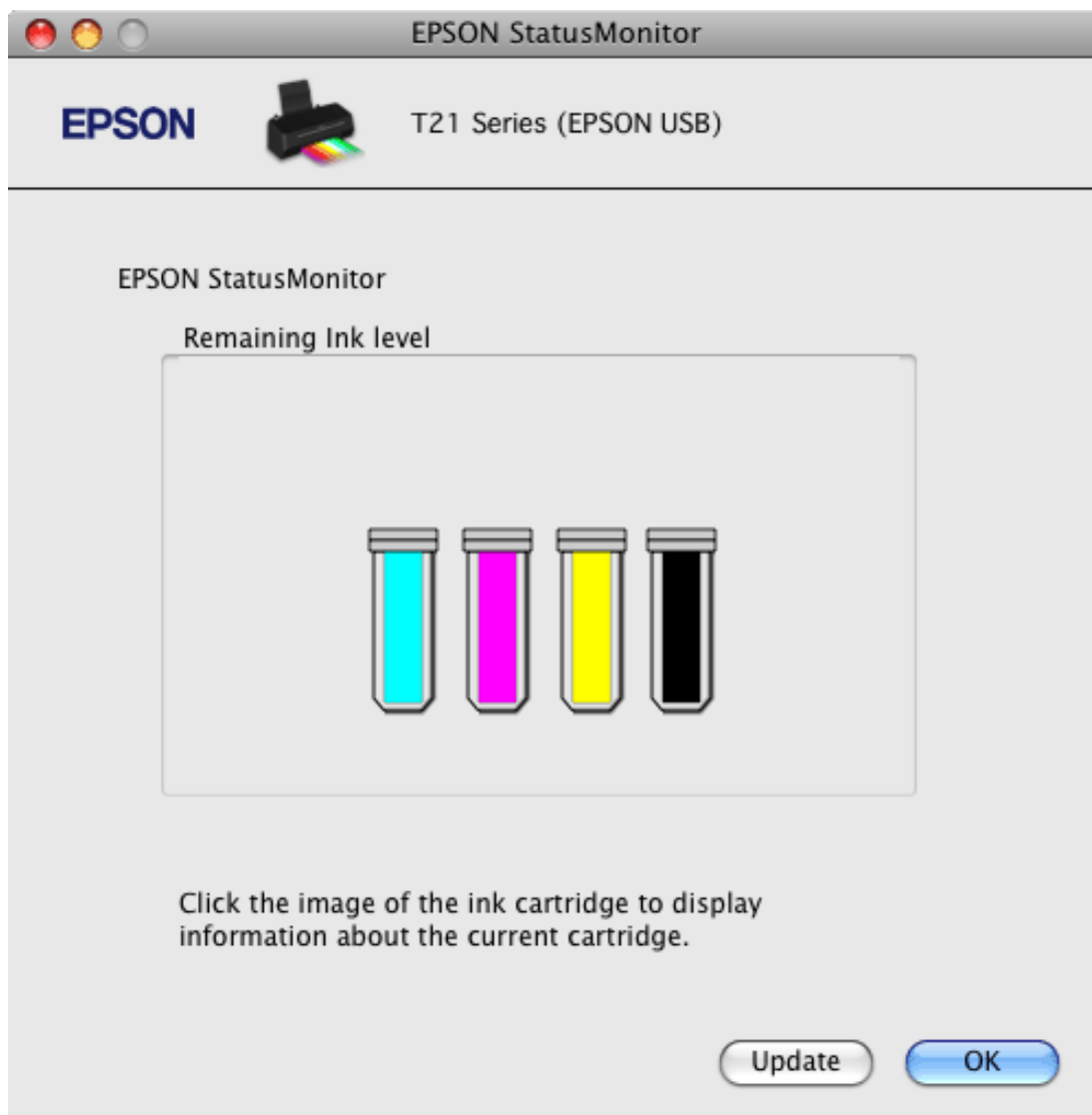

 **Note:**

- - The graphic displays the ink cartridge status when EPSON StatusMonitor was first opened. To update the ink cartridge status, click **Update**.
- - Epson cannot guarantee the quality or reliability of non-genuine ink. If non-genuine ink cartridges are installed, the ink cartridge status may not be displayed.
- - If any of the ink cartridges installed in the printer is broken, incompatible with the printer model, or improperly installed, EPSON StatusMonitor will not display an accurate status of the ink cartridge. Be sure to replace or reinstall any ink cartridge indicated by the EPSON StatusMonitor.

 **Note for Mac OS X 10.5.x**

The printer monitor window appears automatically when you start a print job. You can check the ink cartridge status from this window.

[Home](#) > [Replacing Ink Cartridges](#)

■ Precautions on Ink Cartridge Replacement

Read all of the instructions in this section before replacing the ink cartridges.

- - This printer uses ink cartridges equipped with an IC chip that monitors the amount of ink used by each cartridge. Cartridges are usable even if they are removed and reinserted.
- - Some ink is consumed from all cartridges during the following operations: print head cleaning and ink charging when an ink cartridge is installed.
- - If you need to remove an ink cartridge temporarily, be sure to protect the ink supply area from dirt and dust. Store the ink cartridge in the same environment as the printer. When storing the cartridge, be sure that its label identifying the color of the ink cartridge is facing upward. Do not store ink cartridges upside down.
- - The valve in the ink supply port is designed to contain any excess ink that may be released. However, careful handling is recommended. Do not touch the supply port of the ink cartridge or its surrounding area.
- - For maximum ink efficiency, only remove an ink cartridge when you are ready to replace it. Ink cartridges with low ink status may not be used when reinserted.
- - Other products not manufactured by Epson may cause damage that is not covered by Epson's warranties, and under certain circumstances, may cause erratic printer behavior.
- - Keep ink cartridges out of the reach of children. Do not allow children to drink from or handle the cartridges.
- - Be careful when you handle used ink cartridges, as there may be some ink around the ink supply port. If ink gets on your skin, wash the area thoroughly with soap and water. If ink gets into your eyes, flush them immediately with water. If discomfort or vision problems continue after a thorough flushing, see a doctor immediately.
- - Epson recommends the use of genuine Epson ink cartridges. Epson cannot guarantee the quality or reliability of non-genuine ink. The use of non-genuine ink may cause damage that is not covered by Epson's warranties, and under certain circumstances, may cause erratic printer behavior. Information about non-genuine ink levels may not be displayed, and use of non-genuine ink is recorded for possible use in service support.
- - Do not open the ink cartridge package until you are ready to install it in the printer. The cartridge is vacuum packed to maintain its reliability.
- - Leave the old cartridge installed in the printer until you have obtained a replacement; otherwise, ink remaining in the print head nozzles may dry out.
-
-

- You cannot continue printing with one ink cartridge expended, even if the other cartridges still contain ink. Before printing, replace the expended cartridge.

[Home](#) > [Replacing Ink Cartridges](#)

■ Conserving Black Ink When the Cartridge Is Low (Windows Only)

The window below appears when black ink runs low and there is more color ink than black ink. It appears only when **Plain paper / Bright White Paper** is selected as the paper type, and **Text** is selected as the Quality Option.

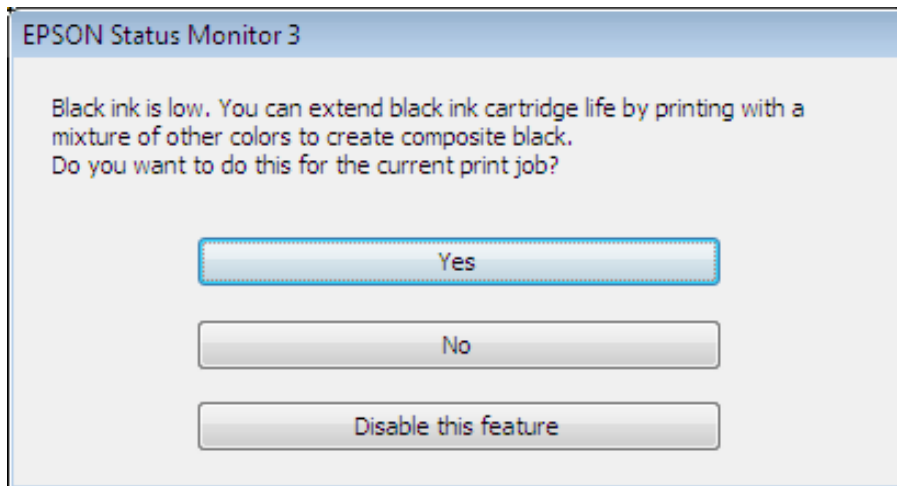

The window gives you the option to either continue using black ink normally or conserve black ink by using a mixture of color inks to create black.

- Click the **Yes** button to use a mixture of color inks to create black. You will see the same window the next time you print a similar job.
- Click the **No** button to continue using the remaining black ink for the job you are printing. You will see the same window the next time you print a similar job, and again have the option to conserve black ink.
- Click **Disable this feature** to continue using the remaining black ink.

Home > Replacing Ink Cartridges

■ Replacing an Expended Ink Cartridge

 [Using the Printer Buttons](#)

 [Using Your Computer](#)



You can replace an ink cartridge using the printer buttons or using your computer. Refer to the appropriate section below for instructions.

 **Note:**

Do not open the ink cartridge package until you are ready to install it in the printer. The cartridge is vacuum packed to maintain its reliability.

Using the Printer Buttons

This table describes the status of the lights and the actions you need to take.

Lights	Action
	Obtain a replacement ink cartridge.
	Replace the expended ink cartridge.

 flashing,  on

 **Note:**

If an ink cartridge is low, you may continue to use it until it is expended. To confirm the status of each ink cartridge, see one of the following sections:

 See [Using EPSON Status Monitor 3 \(Windows\)](#)

 See [Using EPSON StatusMonitor \(Mac OS X\)](#)





To replace an ink cartridge using the  maintenance button, follow the steps below.

 **Caution:**

Do not remove the cartridge from the printer until you are ready to replace it with another.

 **Note:**

The illustrations show replacement of the cyan ink cartridge, but the instructions are the same for all the cartridges.

- 1 Make sure the  power light is on, but not flashing.
- 2 Open the printer cover.
- 3 Press the  maintenance button. The print head moves to the ink cartridge check position and the  power light begins to flash. The ink cartridge indicated by the  mark is expended.

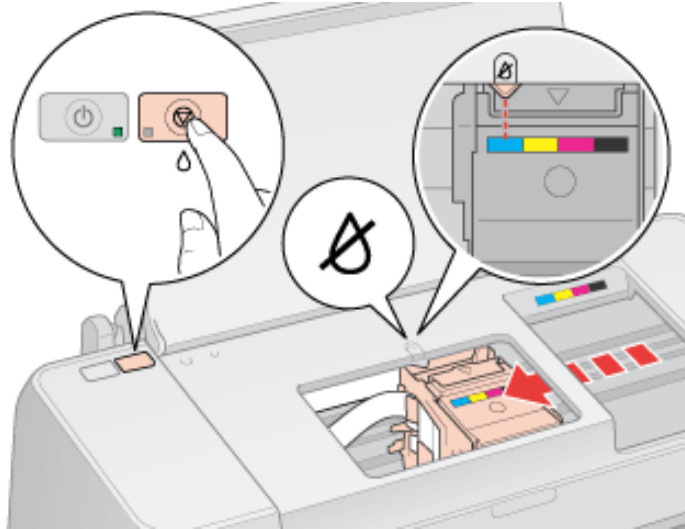

 **Caution:**

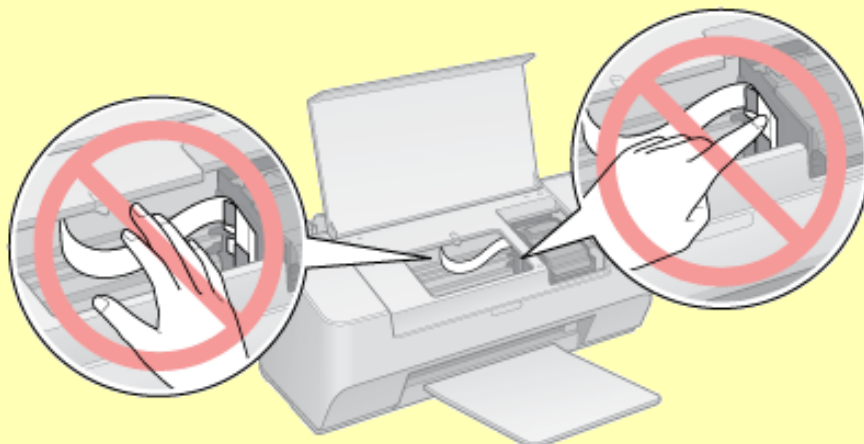

- - Do not move the print head by hand, as this may damage the printer. Always press the  maintenance button to move it.
- - Be careful not to touch the white flat cable inside the printer.



 **Note:**

Do not hold the  maintenance button for more than three seconds, or the printer may start cleaning the print head.

4 Press the  maintenance button again.

If more than one ink cartridge is expended, the print head moves to the  mark. This occurs each time you press the  maintenance button until all expended ink cartridges have been indicated.

Once all of the expended ink cartridges have been indicated, the print head moves to the ink cartridge replacement position when you press the  maintenance button.

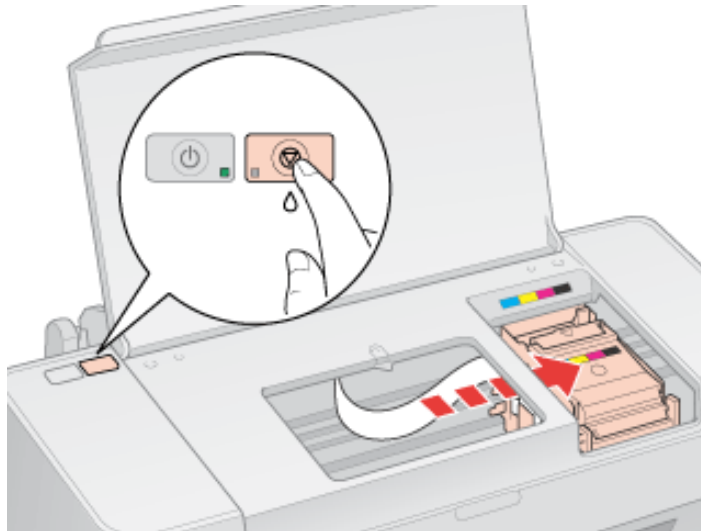

5 For best results, shake the new ink cartridge four or five times before opening the package.



6 Remove the new ink cartridge from the package.

 **Caution:**

- - Be careful not to break the hooks on the side of the ink cartridge when you remove it from the package.
- - Do not touch the green IC chip on the side of the cartridge. This can damage the ink cartridge.



- - Always install an ink cartridge immediately after removing the old cartridge. If the cartridge is not installed promptly, the print head may dry out and be unable to print.

7 Remove the yellow tape from the bottom of the ink cartridge.



 **Caution:**

- - You must remove the yellow tape from the cartridge before installing it; otherwise, print quality may decline or you may not be able to print.
- - If you have installed an ink cartridge without removing the yellow tape, take the cartridge out of the printer, remove the yellow tape, and then reinstall it.
- - Do not remove the transparent seal from the bottom of the cartridge; otherwise, the cartridge may become unusable.

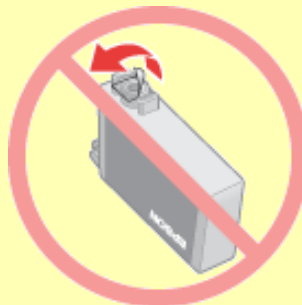

- Do not remove or tear the label on the cartridge; otherwise, ink will leak.

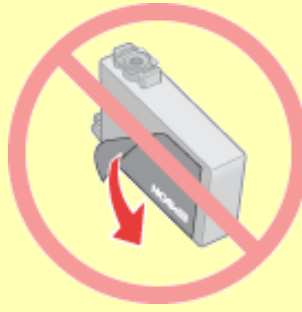

- 8 Open the cartridge cover.

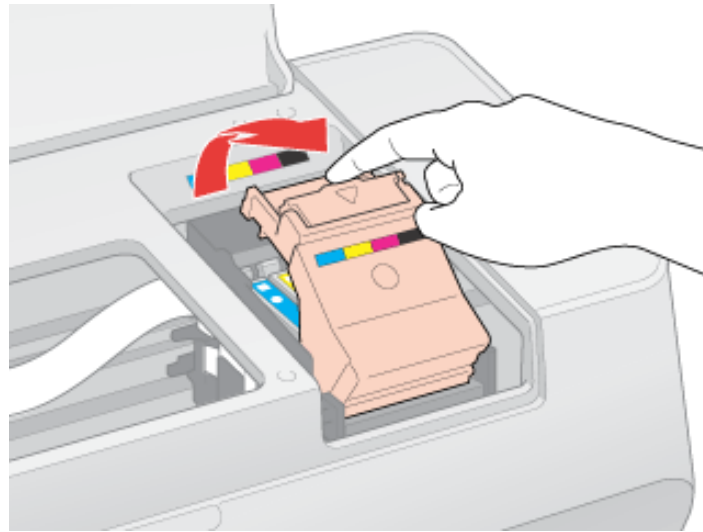

 **Caution:**

Be careful not to touch the parts highlighted below.

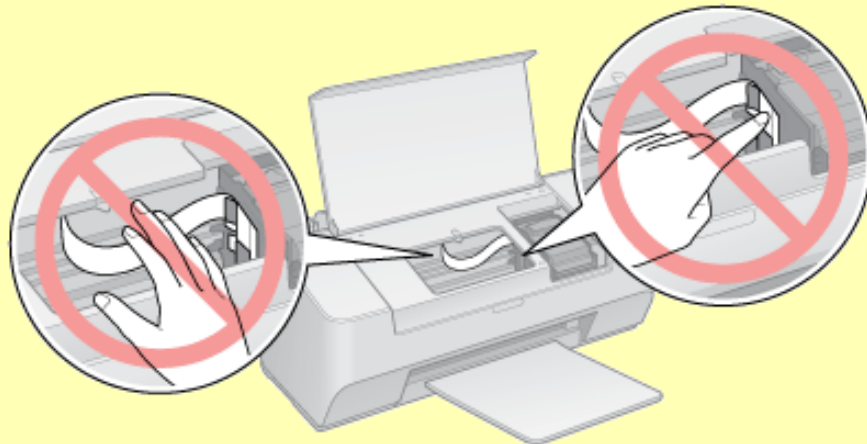

- 9 Squeeze the tab at the back of the ink cartridge that you want to replace. Lift the cartridge straight up and out of the printer. Dispose of it properly.

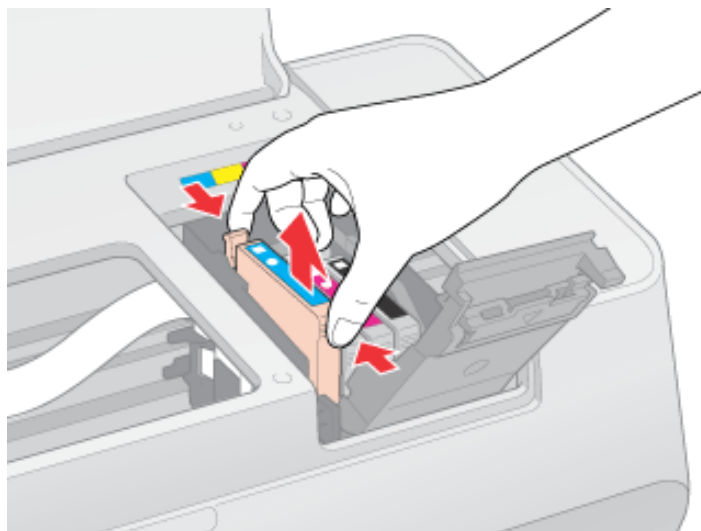

 **Note:**

If it is difficult to remove the cartridge, lift the cartridge with more force until it comes out.

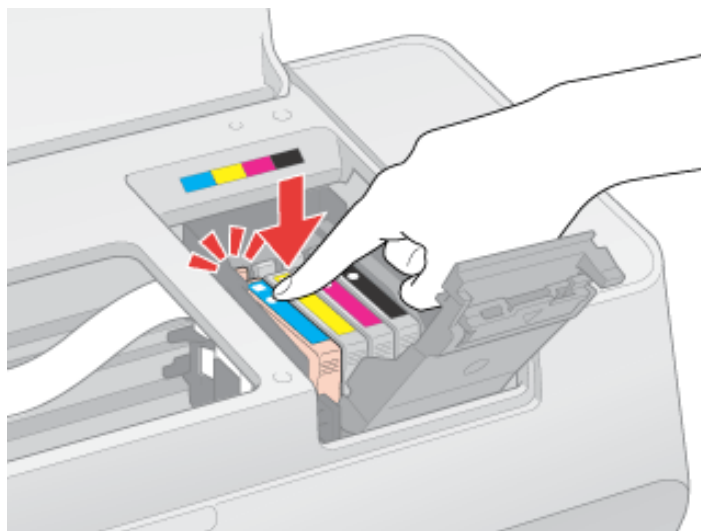

- 10 Place the ink cartridge into the cartridge holder with the bottom down. Then push down the ink cartridge until it clicks into place.

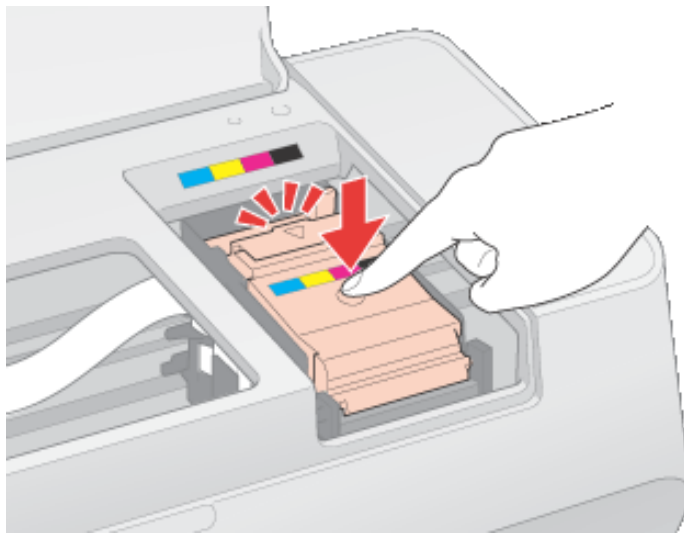

- 11 When you are finished replacing cartridges, close the cartridge cover and the printer cover.



12 Press the  maintenance button.

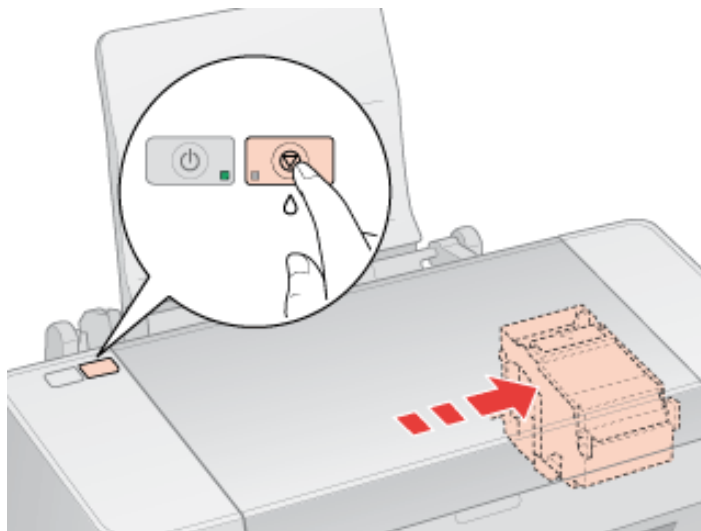

The printer moves the print head and begins charging the ink delivery system. This process takes about one and a half minutes to complete. When ink charging is finished, the print head returns to its home position. The  power light stop flashing and remains on, and the  error light goes out.



 **Caution:**

The  power light continues to flash while the printer is charging ink. Never turn off the printer while this light is flashing. Doing so can result in incomplete charging of ink.

 **Note:**

If the  error light is flashing or is on after the print head moves to its home position, the ink cartridge may not be installed properly. Press the  maintenance button again, press the ink cartridge down until it clicks into place, and then close the cartridge cover firmly.

Using Your Computer

You can monitor the ink cartridge status from your computer and view on-screen instructions for replacing a low or expended ink cartridge.

When you need to replace an ink cartridge, click **How to** in the EPSON Status Monitor window. Follow the on-screen instructions to replace the cartridge.

For more information on using your computer to replace ink cartridges, see the section below.

 See [Using EPSON Status Monitor 3 \(Windows\)](#)

 See [Using EPSON StatusMonitor \(Mac OS X\)](#)

[Home](#) > [Replacing Ink Cartridges](#)

Replacing an Ink Cartridge Before It Is Expended

 [Using Your Computer for Windows](#)

 [Using Your Computer for Mac OS X](#)

You may need to replace an ink cartridge before it is expended if it has been installed in your printer for more than six months and print quality declines.

To replace an ink cartridge before the  error light turns on or EPSON Status Monitor notifies you that the cartridge is expended, follow the instructions in this section.

Note:

- - You can only replace an ink cartridge by using the printer buttons when an ink cartridge is expended.
- - Do not open the ink cartridge package until you are ready to install it in the printer. The cartridge is vacuum packed to maintain its reliability.

Using Your Computer for Windows

You can view on-screen instructions for replacing an ink cartridge using the printer maintenance utilities.

If you need to replace an ink cartridge before it is low or expended, click the button on the **Maintenance** tab.

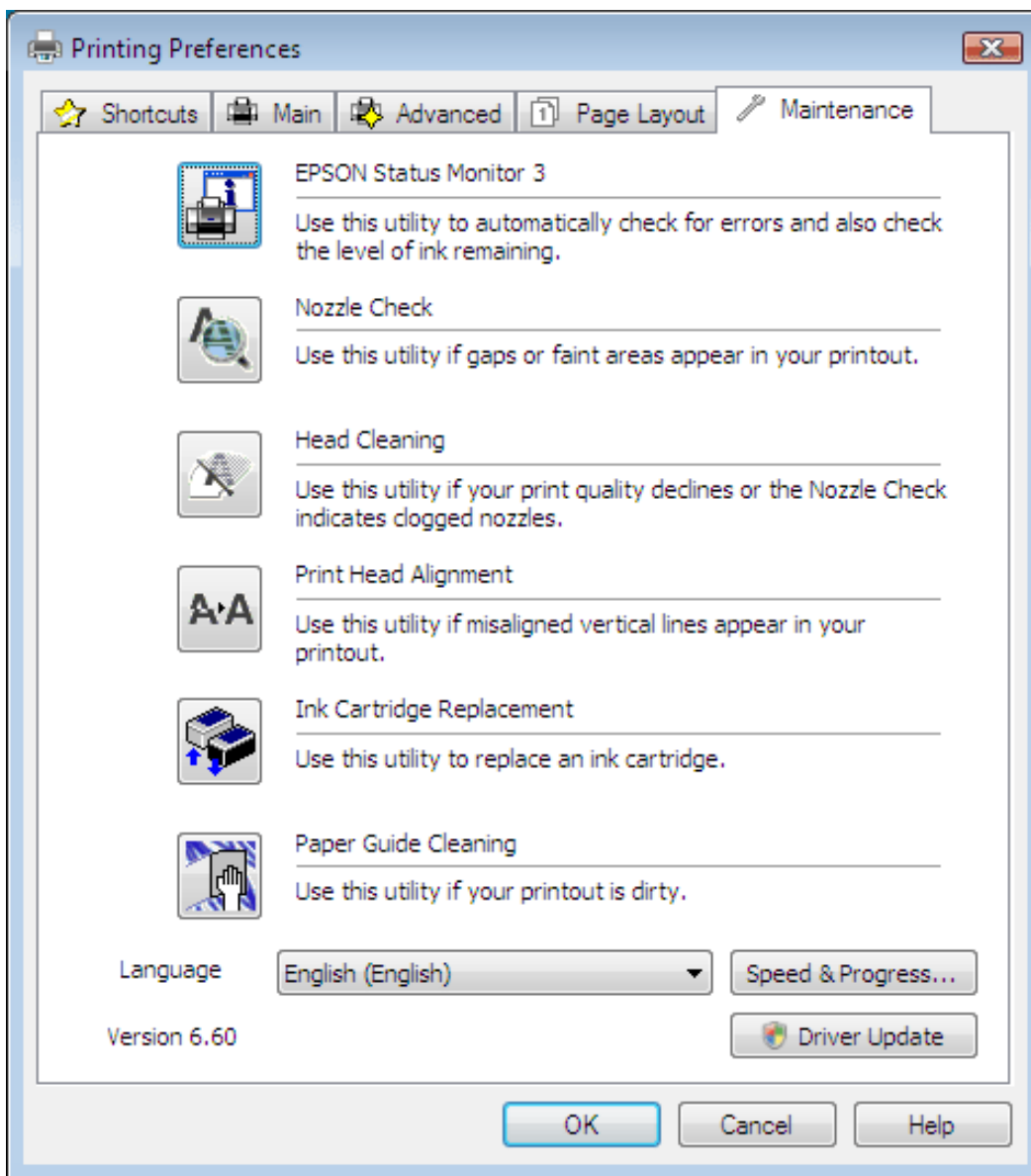

For more information on using the printer utilities, see the online help.

[Top](#) 

Using Your Computer for Mac OS X

If you need to replace an ink cartridge before it is low or expended, access the EPSON Printer Utility3 dialog box.

 [Accessing the printer driver for Mac OS X](#)

EPSON Printer Utility3

EPSON  T21 Series (EPSON USB)

 **EPSON StatusMonitor**
Use this utility to automatically check for errors and also check the level of ink remaining.

 **Nozzle Check**
Use this utility if gaps or faint areas appear in your printout.

 **Head Cleaning**
Use this utility if your print quality declines or the Nozzle Check indicates clogged nozzles.

 **Print Head Alignment**
Use this utility if misaligned vertical lines appear in your printout.

 **Paper Guide Cleaning**
Use this utility if your printout is dirty.

 **Ink Cartridge Replacement**
Use this utility to replace an ink cartridge.

[Home](#) > [Maintaining Your Printer](#)

■ Checking the Print Head Nozzles

- [Using the Nozzle Check Utility for Windows](#)
- [Using the Nozzle Check Utility for Mac OS X](#)
- [Using the Printer Buttons](#)

If you find that the printout is unexpectedly faint or that dots are missing, you may be able to identify the problem by checking the print head nozzles.

You can check the print head nozzles from your computer by using the Nozzle Check utility or from the printer by using the buttons.

Using the Nozzle Check Utility for Windows

Follow the steps below to use the Nozzle Check utility.

- 1 Make sure that no lights are indicating errors.
- 2 Make sure that Letter- or A4-size paper is loaded in the sheet feeder.
- 3 Right-click the printer icon on the taskbar, then select **Nozzle Check**.

If the printer icon does not appear, refer to the following section to add the icon.

 [From the Shortcut Icon on the Taskbar](#)

- 4 Follow the on-screen instructions.

[Top](#) 

Using the Nozzle Check Utility for Mac OS X

Follow the steps below to use the Nozzle Check utility.

- 1 Make sure that no lights are indicating errors.
- 2 Make sure that Letter- or A4-size paper is loaded in the sheet feeder.
- 3 Access the EPSON Printer Utility3 dialog box.



 [Accessing the Printer Driver for Mac OS X](#)

- 4 Click the **Nozzle Check** button in the Utility dialog box.

- 5 Follow the on-screen instructions.

Using the Printer Buttons

Follow the steps below to check the print head nozzles using the printer buttons.

- 1 Make sure that no lights are indicating errors.
- 2 Turn off the printer.
- 3 Make sure that Letter- or A4-size paper is loaded in the sheet feeder.
- 4 Hold down the  maintenance button and press the  power button to turn on the printer.

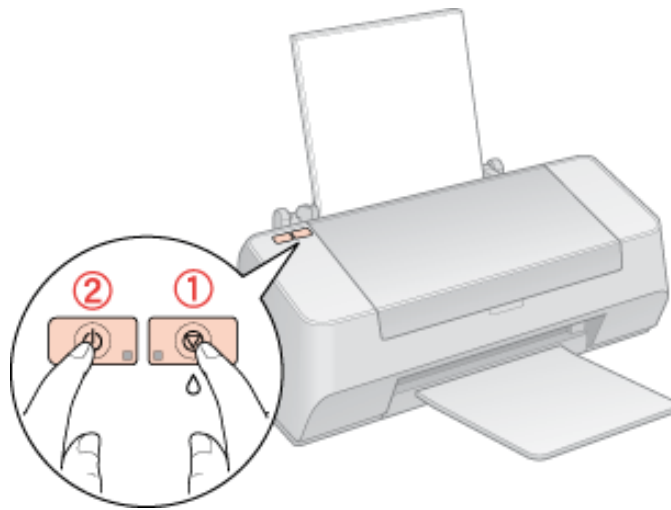

- 5 When the printer turns on, release both the buttons. The printer prints the nozzle check pattern.

Below are two sample nozzle check patterns.

Compare the quality of the printed check page with the sample shown below. If there are no print quality problems, such as gaps or missing segments in the test lines, the print head is fine.

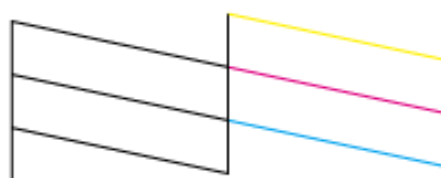

If any segment of the printed lines is missing, as shown below, this could mean a clogged ink nozzle or a misaligned print head.

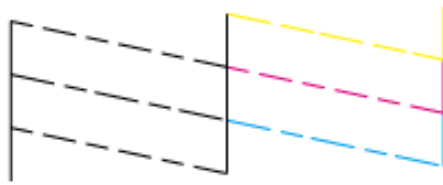

 See [Cleaning the Print Head](#)

 See [Aligning the Print Head](#)

Home > Maintaining Your Printer

Cleaning the Print Head

 [Using the Head Cleaning Utility for Windows](#)

 [Using the Head Cleaning Utility for Mac OS X](#)

 [Using the Printer Buttons](#)

If you find that the printout is unexpectedly faint or that dots are missing, you may be able to solve these problems by cleaning the print head, which ensures that the nozzles are delivering ink properly.

You can clean the print head from your computer using the Head Cleaning utility in the printer driver or from the printer by using the buttons.

Note:

- - Because print head cleaning uses ink from all cartridges, clean the print head only if print quality declines; for example, if the printout is blurry or the color is incorrect or missing.
- - Use the Nozzle Check utility first to confirm that the print head needs to be cleaned. This saves ink.
- - When ink is low you may not be able to clean the print head. When ink is expended you cannot clean the print head. Replace the appropriate ink cartridge first.

Using the Head Cleaning Utility for Windows

Follow the steps below to clean the print head using the Head Cleaning utility.

- 1 Make sure the printer is turned on.
- 2 Make sure that no lights are indicating errors.
- 3 Right-click the printer icon on the taskbar, then select **Head Cleaning**.

If the printer icon does not appear, refer to the following section to add the icon.

 [From the shortcut icon on the taskbar](#)

- 4 Follow the on-screen instructions.

The  power light flashes while the printer performs the cleaning cycle.

Caution:

Never turn off the printer while the  power light is flashing. Doing so may damage the printer.

 **Note:**

- - If print quality has not improved after repeating this procedure about four times, turn the printer off and wait for at least six hours. Then run the nozzle check again and repeat the head cleaning if necessary. If print quality has still not improved, contact Epson support.
- - To maintain print quality, we recommend printing a few pages on a regular basis.

Top 

Using the Head Cleaning Utility for Mac OS X

Follow the steps below to clean the print head using the Head Cleaning utility.

- 1 Make sure the printer is turned on.
- 2 Make sure that no lights are indicating errors.
- 3 Access the EPSON Printer Utility3.
 [Accessing the Printer Driver for Mac OS X](#)
- 4 Click the **Head Cleaning** button in the Utility dialog box.
- 5 Follow the on-screen instructions.

The  power light flashes while the printer performs the cleaning cycle.

 **Caution:**

Never turn off the printer while the  power light is flashing. Doing so may damage the printer.

 **Note:**

- - If print quality has not improved after repeating this procedure about four times, turn the printer off and wait for at least six hours. Then run the nozzle check again and repeat the head cleaning if necessary. If print quality has still not improved, contact Epson support.
- - To maintain print quality, we recommend printing a few pages on a regular basis.

Top 

Using the Printer Buttons

Follow the steps below to clean the print head using the printer buttons.

- 1 Make sure that no lights are indicating errors.
- 2 Make sure that Letter- or A4-size paper is loaded in the sheet feeder.
- 3 Press and hold down the  maintenance button for three seconds.

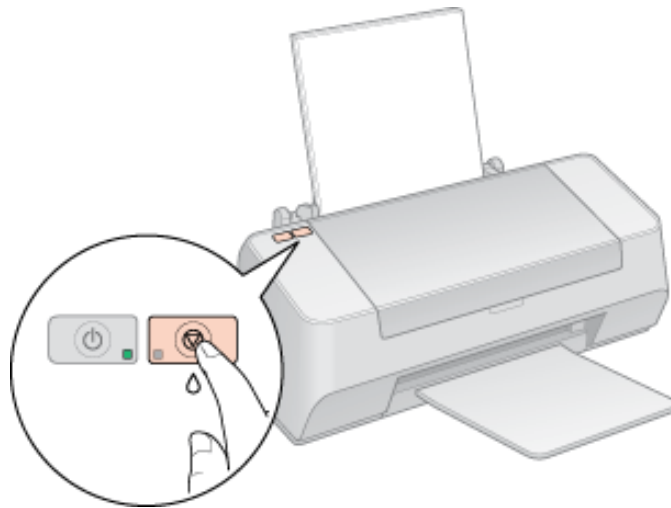

The printer starts cleaning the print head and the  power light begins flashing.

Caution:

Never turn off the printer while the  power light is flashing. Doing so may damage the printer.

- 4 When the  power light stops flashing, print a nozzle check pattern to confirm that the head is clean.

 [Checking the Print Head Nozzles](#)

Note:

- - If print quality has not improved after repeating this procedure about four times, turn the printer off and wait for at least six hours. Then run the nozzle check again and repeat the head cleaning if necessary. If print quality has still not improved, contact Epson customer support.

 See [Contacting Technical Support](#)

- - To maintain print quality, we recommend printing a few pages on a regular basis.

[Home](#) > [Maintaining Your Printer](#)

Aligning the Print Head

 [Using the Print Head Alignment Utility for Windows](#)

 [Using the Print Head Alignment Utility for Mac OS X](#)

If you notice a misalignment of vertical lines or horizontal banding, you may be able to solve this problem by using the Print Head Alignment utility in your printer driver.

Refer to the appropriate section below.



Note:

Do not press the  maintenance button to cancel printing while printing a test pattern with the Print Head Alignment utility.

Using the Print Head Alignment Utility for Windows

Follow the steps below to align the print head using the Print Head Alignment utility.

- 1 Make sure that no lights are indicating errors.
- 2 Make sure Letter- or A4-size paper is loaded in the sheet feeder.
- 3 Right-click the printer icon on the taskbar, then select **Print Head Alignment**.

If the printer icon does not appear, refer to the following section to add the icon.

 [From the Shortcut Icon on the Taskbar](#)

- 4 Follow the on-screen instructions to align the print head.

[Top](#) 

Using the Print Head Alignment Utility for Mac OS X

Follow the steps below to align the print head using the Print Head Alignment utility.

- 1 Make sure that no lights are indicating errors.
- 2 Make sure Letter- or A4-size paper is loaded in the sheet feeder.
- 3 Access the EPSON Printer Utility³ dialog box.

 [Accessing the Printer Driver for Mac OS X](#)

4 Click the **Print Head Alignment** button in the Utility dialog box.

5 Follow the on-screen instructions to align the print head.

[Home](#) > [Maintaining Your Printer](#)

Cleaning the Paper Guide

 [Using the Paper Guide Cleaning Utility for Windows](#)

 [Using the Paper Guide Cleaning Utility for Mac OS X](#)

You may see a smudge on the back of the printout when excessive ink remains on the paper guide. The paper guide is the dark plastic strip inside the printer. In this case, you can solve the problem by using the Paper Guide Cleaning utility in your printer driver.

Refer to the appropriate section below.



Note:

Repeat the procedure until the inside of the printer is cleaned.

Using the Paper Guide Cleaning Utility for Windows

Follow the steps below to clean the paper guide using the Paper Guide Cleaning utility.

- 1 Make sure that no lights are indicating errors.
- 2 Make sure Letter- or A4-size paper is loaded in the sheet feeder.
- 3 Open the printer driver, click the **Maintenance** tab, then click the **Paper Guide Cleaning** button.



[Accessing the Printer Driver for Windows](#)

- 4 Follow the on-screen instructions to clean the paper guide.

[Top](#) 

Using the Paper Guide Cleaning utility for Mac OS X

Follow the steps below to clean the paper guide using the Paper Guide Cleaning utility.

- 1 Make sure that no lights are indicating errors.
- 2 Make sure Letter- or A4-size paper is loaded in the sheet feeder.
- 3 Access the EPSON Printer Utility3 dialog box.



[Accessing the Printer Driver for Mac OS X](#)

4 Click the **Paper Guide Cleaning** button in the Utility dialog box.

5 Follow the on-screen instructions to clean the paper guide.

[Home](#) > [Maintaining Your Printer](#)

■ **Cleaning Your Printer**

 [Cleaning the Exterior of the Printer](#)

 [Cleaning the Interior of the Printer](#)

Cleaning the Exterior of the Printer

To keep your printer operating at its best, clean it thoroughly several times a year by using the following instructions.



Caution:

Never use alcohol or thinner to clean the printer. These chemicals can damage the printer.

[Top](#) 

Cleaning the Interior of the Printer

To keep your printouts at their best, clean the roller inside by using the Paper Guide Cleaning utility.

 [Cleaning the Paper Guide](#)

[Top](#) 

[Home](#) > [Maintaining Your Printer](#)

■ Transporting Your Printer

If you need to transport your printer some distance, carefully prepare and repack it as described below. Use the original box and packing materials, or a similar box that holds the printer snugly.

 **Caution:**

- - When storing or transporting the printer, avoid tilting it, placing it vertically, or turning it upside down; otherwise ink may leak from the cartridges.
- - Leave the ink cartridges installed. Removing the cartridges can dehydrate the print head and may prevent the printer from printing.

- 1** Plug in the printer and turn it on. Wait until the ink cartridge holder returns to the home position, then close the printer cover.
- 2** Turn off the printer and unplug its power cord.
- 3** Disconnect the USB cable.
- 4** Remove all paper from the sheet feeder.
- 5** Open the printer cover. Secure the ink cartridge holder with tape, as shown below, then close the printer cover.

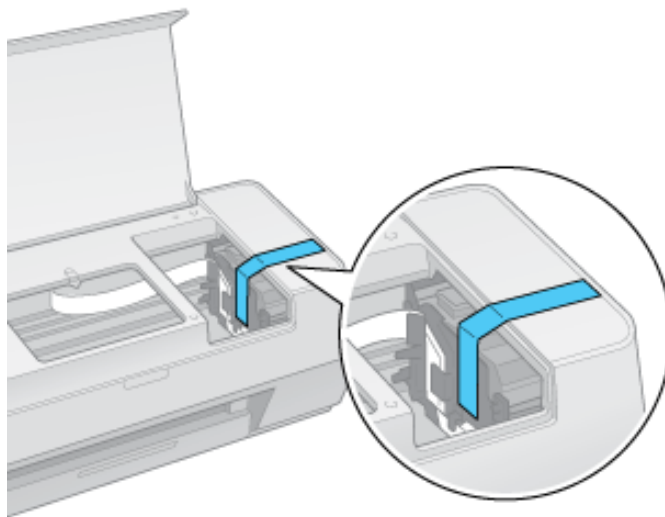

- 6** Remove the output tray and paper support.

7 Attach the protective materials to both sides of the printer.

8 Repack the printer and power cord in the original box.

 **Note:**

- - Keep the printer level during transport.
- - Be sure to remove the protective materials and tape from the printer before using it again.

Home > Doing More with Your Printer

Setup for Windows

- ▾ [Setting up the Printer as a Shared Printer](#)
- ▾ [Adding the Printer to the Other Network Computers](#)

These instructions tell you how to set up your printer so other users on the network can share it.

First you will set up the printer as a shared printer on the computer directly connected to it. Then you will add the printer to each network computer that will access it.

Note:

- - ▣ These instructions are for small networks only. To share the printer on a large network, consult your network administrator.
- - ▣ To uninstall programs in Windows Vista, you need an administrator account and the password if you log on as a standard user.
- - ▣ You must log on to a Computer Administrator account to install software on Windows XP. After you install Windows XP, the user account is set as Computer Administrator.
- - ▣ You must log on to Windows 2000 as a user with administrative privileges (belonging to the Administrators group) to install software.
- - ▣ The illustrations in the following section are from Windows Vista.

Setting Up the Printer as a Shared Printer

Follow the steps below on the computer that is connected directly to the printer:

1 Windows Vista:

Click the  button, select **Control Panel**, and then select **Printer** from the **Hardware and Sound** category.

Windows XP:

Click **Start** and select **Control Panel**, and then select **Printers and Faxes**, from the **Printers and Other Hardware** category.

Windows 2000:

Click **Start**, point to **Settings**, and click **Printers**.

- 2 Right-click the icon for your printer, then click **Sharing**. For Windows Vista, click the **Change sharing options** button and then click **Continue**.

- 3 **Windows Vista and XP:**
Select **Share this printer**, then type a Share name.

Windows 2000:
Select **Shared as**, then type a name for the shared printer.

 **Note:**

Do not use spaces or hyphens in the share name.

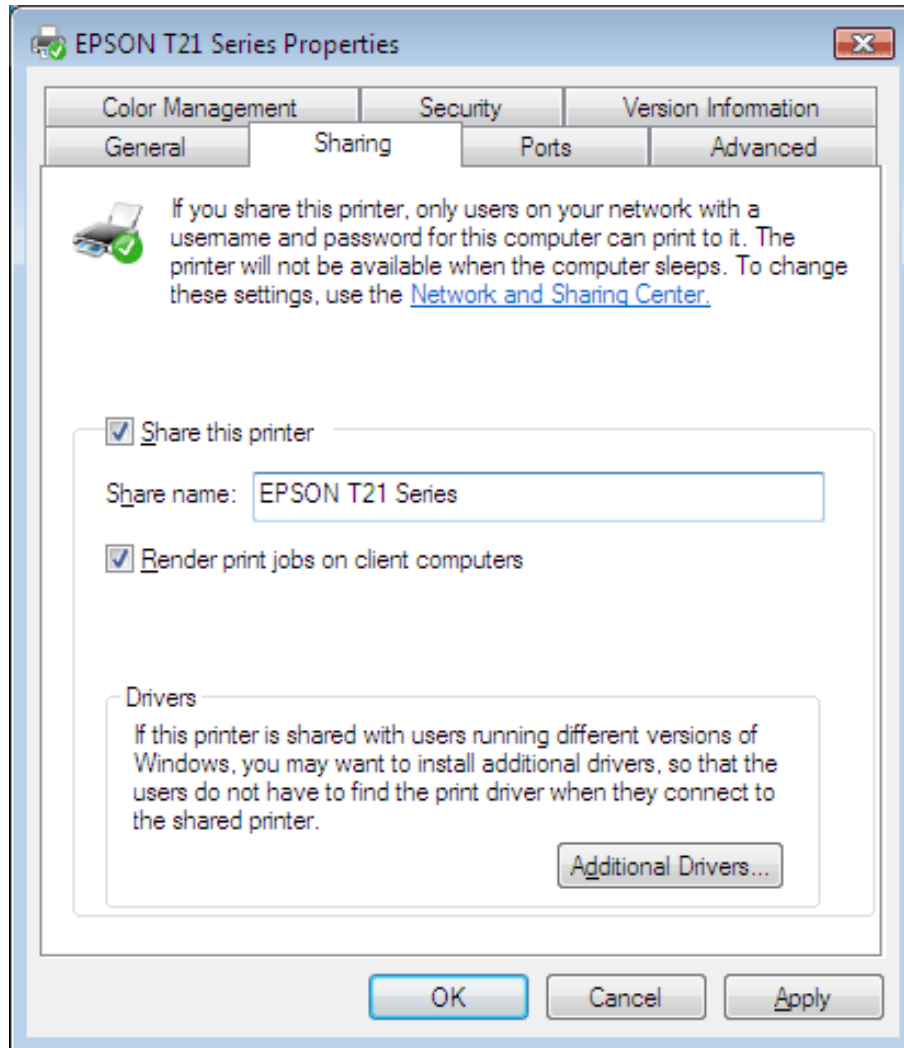

If you want Windows Vista, Windows XP, and Windows 2000 to automatically download printer drivers for computers that are running different versions of Windows, click **Additional Drivers** and select the environment and the operating systems of the other computers. Click **OK**, then insert the printer software CD into the CD-ROM drive.

- 4 Click **OK** or **Close** (if you installed additional drivers).

Top 

Adding the printer to the other network computers

Follow these steps to add the printer to each network computer that will access it.

 **Note:**

Your printer must be set up as a shared printer on the computer to which it is connected before you can access it from another computer.

 See [Setting up the Printer as a Shared Printer](#)

1 Windows Vista:

Click the  button, select **Control Panel**, and then select **Printer** from the **Hardware and Sound** category.

Windows XP:

Click **Start** and select **Control Panel**, and then select **Printers and Faxes**, from the **Printers and Other Hardware** category.

Windows 2000:

Click **Start**, point to **Settings**, and click **Printers**.

2 Windows Vista:

Click the **Add a Printer** button.

Windows XP and 2000:

Double-click the **Add Printer** icon. The Add Printer Wizard appears. Click the **Next** button.

3 Windows Vista:

Click **Add a network, wireless or Bluetooth printer**, and then click **Next**.

Windows XP:

Select **A network printer, or a printer attached to another computer**, then click **Next**.

Windows 2000:

Select **Network printer**, then click **Next**.

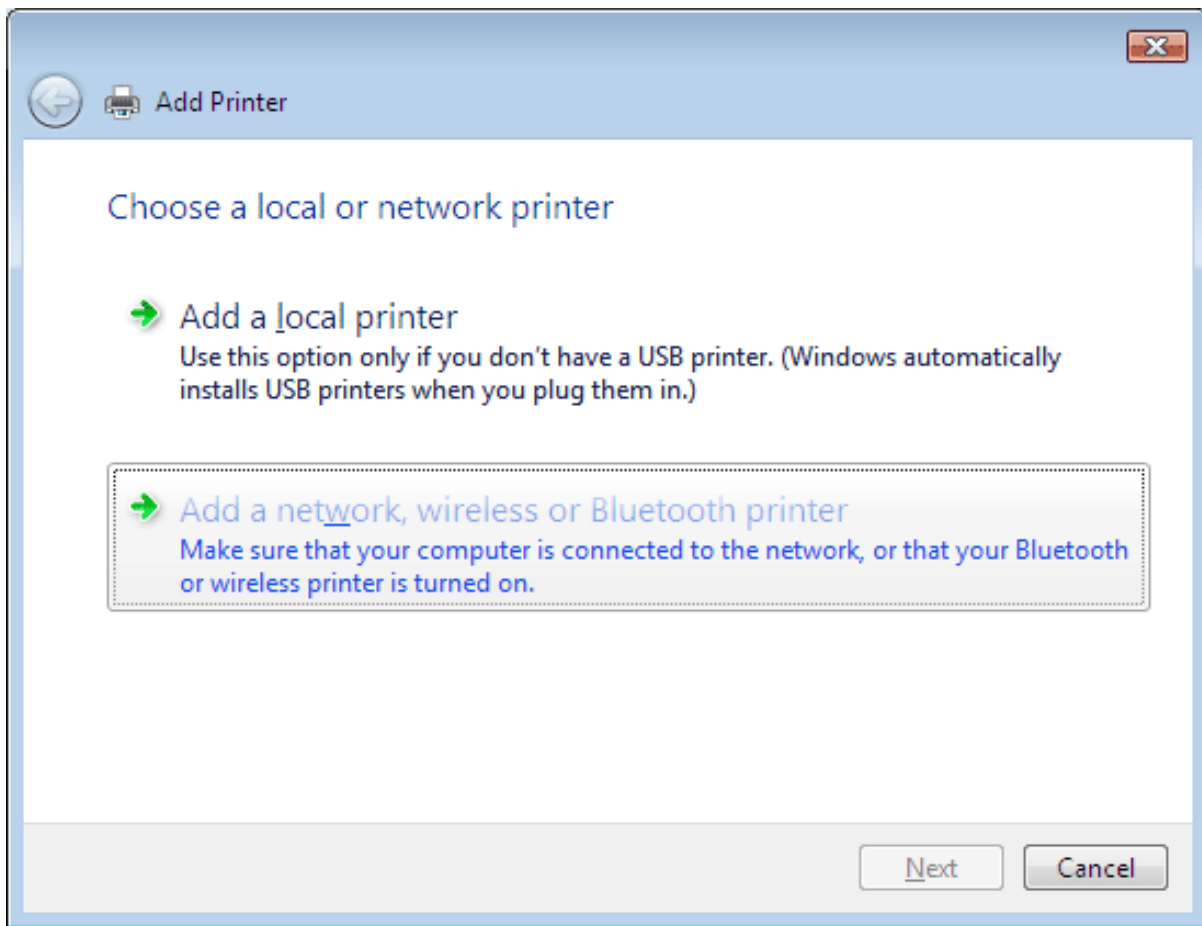

4 Follow the on-screen instructions to select the printer you want to use.

 **Note:**

Depending on the operating system and the configuration of the computer to which the printer is connected, the Add Printer Wizard may prompt you to install the printer driver from the printer software CD-ROM. Click the **Have Disk** button and follow the on-screen instructions.

[Home](#) > [Doing More with Your Printer](#)

■ Setup for Mac OS X

To set up your printer on a Mac OS X network, use the Printer Sharing setting. See your Macintosh documentation for details.

 **Note:**

When your printer is shared on a Mac OS X network, the  EPSON Printer Utility3 icon does not appear in the Print window.

 **Note for Mac OS X 10.5.x:**

When your printer is shared on a Mac OS X network, the Low Ink Reminder screen does not appear.

[Home](#) > [Problem Solver](#)

Diagnosing the Problem

-  [Error Indicators](#)
-  [EPSON Status Monitor 3 \(Windows Only\)](#)
-  [Running a Printer Operation Check](#)

Troubleshooting printer problems is best handled in two steps: first diagnose the problem, then apply likely solutions until the problem is fixed.

The information that you need to diagnose and solve most common problems is provided by online problem solving, the control panel, the Status Monitor utility, or by running a printer operation check. Refer to the appropriate section below.







If you have a specific problem relating to print quality, a printout problem not related to print quality, or a paper feeding problem, or if the printer does not print at all, refer to the appropriate section.









To solve a problem, you may need to cancel printing.





 [Canceling Printing](#)

Error Indicators

You can identify many common printer problems using the lights on your printer. If the printer stops working and the lights are on or flashing, use the following table to diagnose the problem, then follow the recommended corrective measures.

Lights	Problem and solution	
  	Paper out	
	No paper is loaded.	Load paper into the sheet feeder, and then press the  maintenance button. The printer resumes printing and the light goes out.
	Paper jam	
	Paper has jammed in the printer.	 See The Paper Jams
	Ink expended	
	An ink cartridge is expended or not installed.	Replace the ink cartridge with a new one. If the light is still on after you have replaced the cartridge, it may not be installed correctly. Reinstall the ink cartridge so that it clicks into place.  See Replacing an Expended Ink Cartridge
Wrong cartridge		
The currently installed ink cartridge cannot be used with the printer.	Replace the incompatible cartridge with an appropriate ink cartridge.  See Replacing an Ink Cartridge Before It Is Expended	

	Incorrectly installed ink cartridge	
	An ink cartridge is not installed correctly.	Reinsert the ink cartridge.  See The ink light is flashing or is on after you replace the cartridge
	Multiple feed error	
	During 2-sided printing, the printer feeds more than one sheet of paper at a time.	Load paper in the sheet feeder and press the  maintenance button to resume printing.
	Ink low	
	An ink cartridge is nearly expended.	Obtain a replacement ink cartridge. To determine which cartridge is nearly expended, check the ink cartridge status.  See Checking the Ink Cartridge Status
	Cartridge holder in the wrong position	
	The print head is obstructed by jammed paper or other foreign material and cannot return to the home position.	Turn off the printer. Open the printer cover and remove any paper or other obstructions from the paper path. Then turn the printer back on. If the error does not clear, contact Epson customer support.  See Contacting Technical Support
	Maintenance	
Flashing alternately	The printer's ink pads are at the end of their service life.	Contact Epson support to replace ink pads.  See Contacting Technical Support

  : on,  : off,   : flashing

Top 

EPSON Status Monitor 3 (Windows Only)

If a problem occurs while printing, an error message will appear in the Status Monitor window.

When you need to replace an ink cartridge, click the **How To** button on the window, and EPSON Status Monitor 3 will lead you step-by-step through the cartridge replacement procedure.

If an error message appears indicating the printer's ink pads are nearing the end of their service life, contact Epson support to replace them. When the printer's ink pads are saturated, the printer stops and Epson support is required to continue printing.



Top 

Running a Printer Operation Check

If you are unable to determine the source of the problem, run a printer operation check to help you determine whether the problem comes from the printer or your computer.

To run a printer operation check, follow these steps.

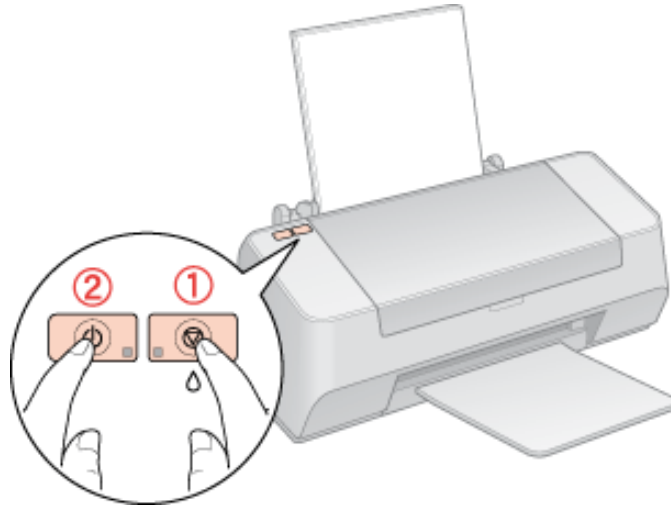

- 1 Make sure both the printer and computer are turned off.

- 2 Disconnect the USB cable.
- 3 Make sure that Letter- or A4- size paper is loaded in the sheet feeder.
- 4 Hold down the  maintenance button and press the  power button to turn on the printer. When the printer turns on, release both the buttons.



A test page prints showing a nozzle check pattern. If the pattern has gaps, you need to clean the print head.

[Cleaning the Print Head](#)

- If the test page prints, the problem probably lies in your software settings, the cable, or your computer. It is also possible that your software may not be installed correctly. Try uninstalling your software and reinstalling it.
 -  See [Uninstalling the Printer Software](#)
- If the test page does not print, you may have a problem with your printer. Try the suggestions in the following section.
 -  See [The printer does not print](#)

[Home](#) > [Problem Solver](#)

■ Checking Printer Status

[For Windows](#)[For Mac OS X](#)

For Windows

Using the progress meter

When you send a print job to the printer, the progress meter appears, as shown in the illustration below.

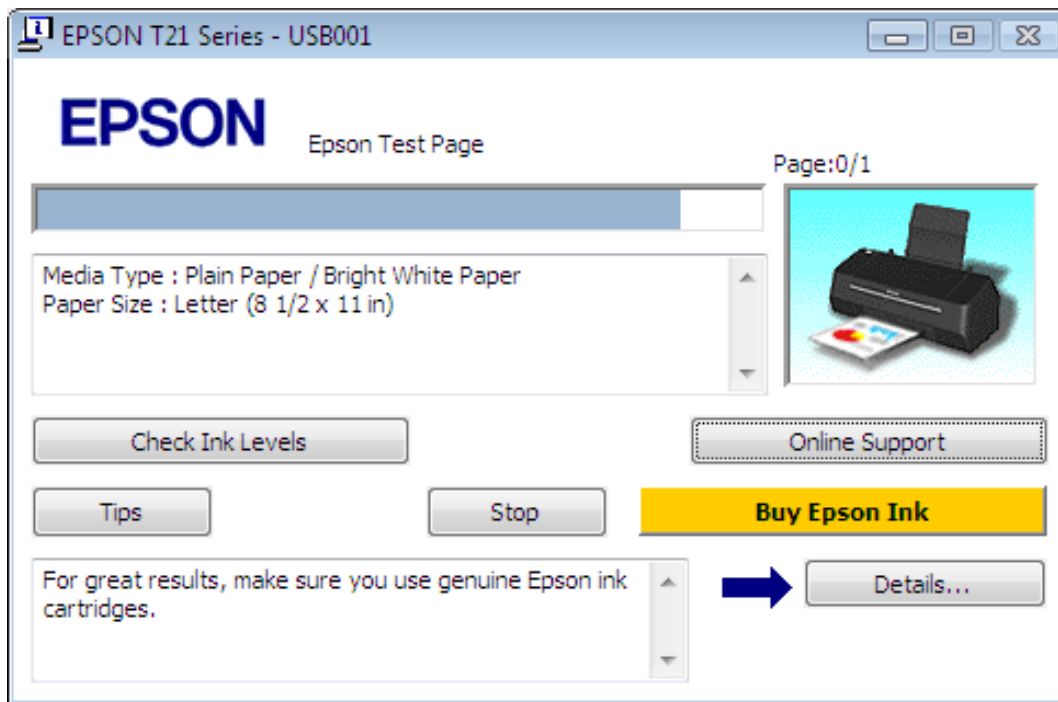

The progress meter indicates the progress of the current print job and provides printer status information. This window also displays error messages as well as helpful tips for better printing. Refer to the appropriate section below.

■ Tips

Various tips for getting the most out of your Epson printer driver appear in the text box of the progress meter window. For more details on the tip displayed in the window, click the **Details** button.

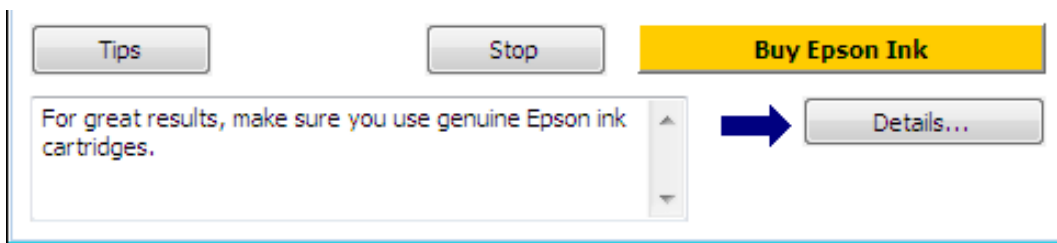

Error messages

If a problem occurs during printing, an error message appears in the text box of the progress meter window. For more detailed information, click **Online Support** to access the online *User's Guide*.

When the ink is low or expended, a **How to** button appears. Click **How to**, and EPSON Status Monitor 3 will lead you step-by-step through the cartridge replacement procedure.

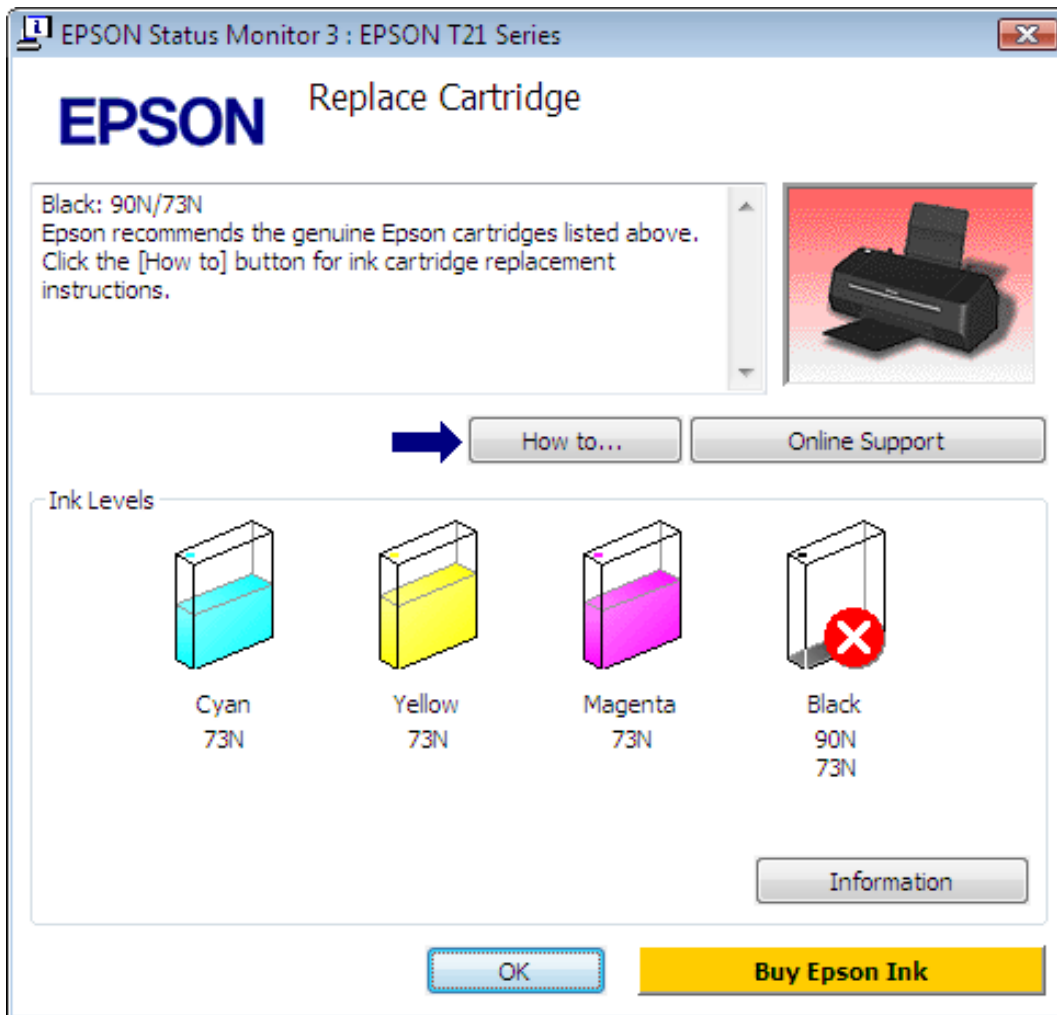

Using EPSON Status Monitor 3

EPSON Status Monitor 3 displays detailed information on the printer status.

There are two ways to access EPSON Status Monitor 3:

- Double-click the printer shortcut icon on the Windows taskbar.
 - ☞ See [From the Shortcut Icon on the Taskbar](#) to add short cut icon on the Windows taskbar.
- Open the printer driver, click the **Maintenance** tab, then click the **EPSON Status Monitor 3** button.

When you access EPSON Status Monitor 3, the following window appears:

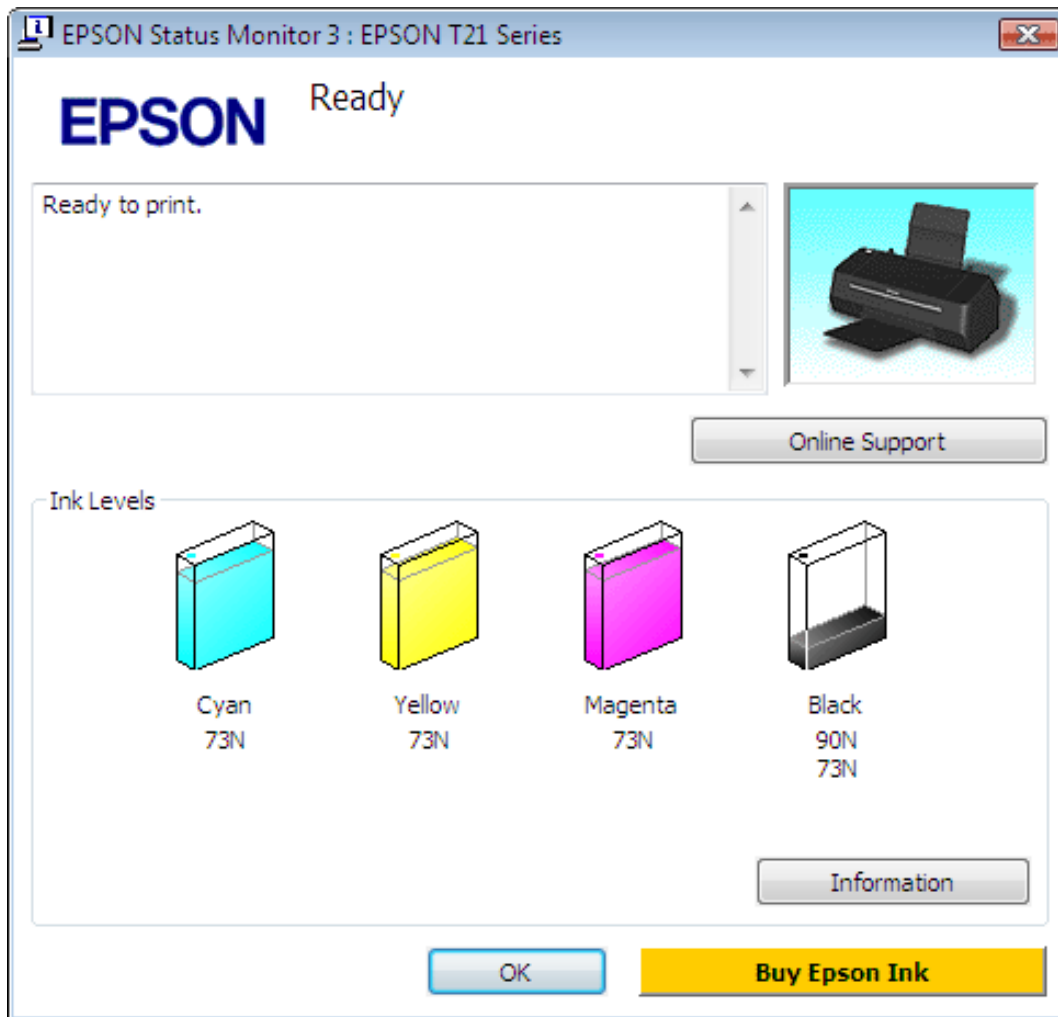

EPSON Status Monitor 3 provides the following information:

- **Current Status:**
If the ink is low or expended, the **How to** button appears in the EPSON Status Monitor 3 window. Clicking **How to** displays ink cartridge replacement instructions and moves the print head to the ink cartridge replacement position.
- **Ink Levels:**
EPSON Status Monitor 3 provides a graphic display of the ink cartridge status.
- **Information:**
You can view information about the installed ink cartridges by clicking **Information**.
- **Online Support:**
You can access Epson's global website from EPSON Status Monitor 3. If you encounter a problem, click **Online Support** in the EPSON Status Monitor 3 window then select your country and go to the Technical Support section of your country's website.

[Top](#)

For Mac OS X

Using EPSON StatusMonitor

If EPSON StatusMonitor detects a printer problem, it will inform you with an error message.

Follow these steps to access EPSON StatusMonitor.

- 1 Access the EPSON Printer Utility3.

 [Accessing the Printer Driver for Mac OS X](#)

- 2 Click the **EPSON StatusMonitor** button. The EPSON StatusMonitor appears.

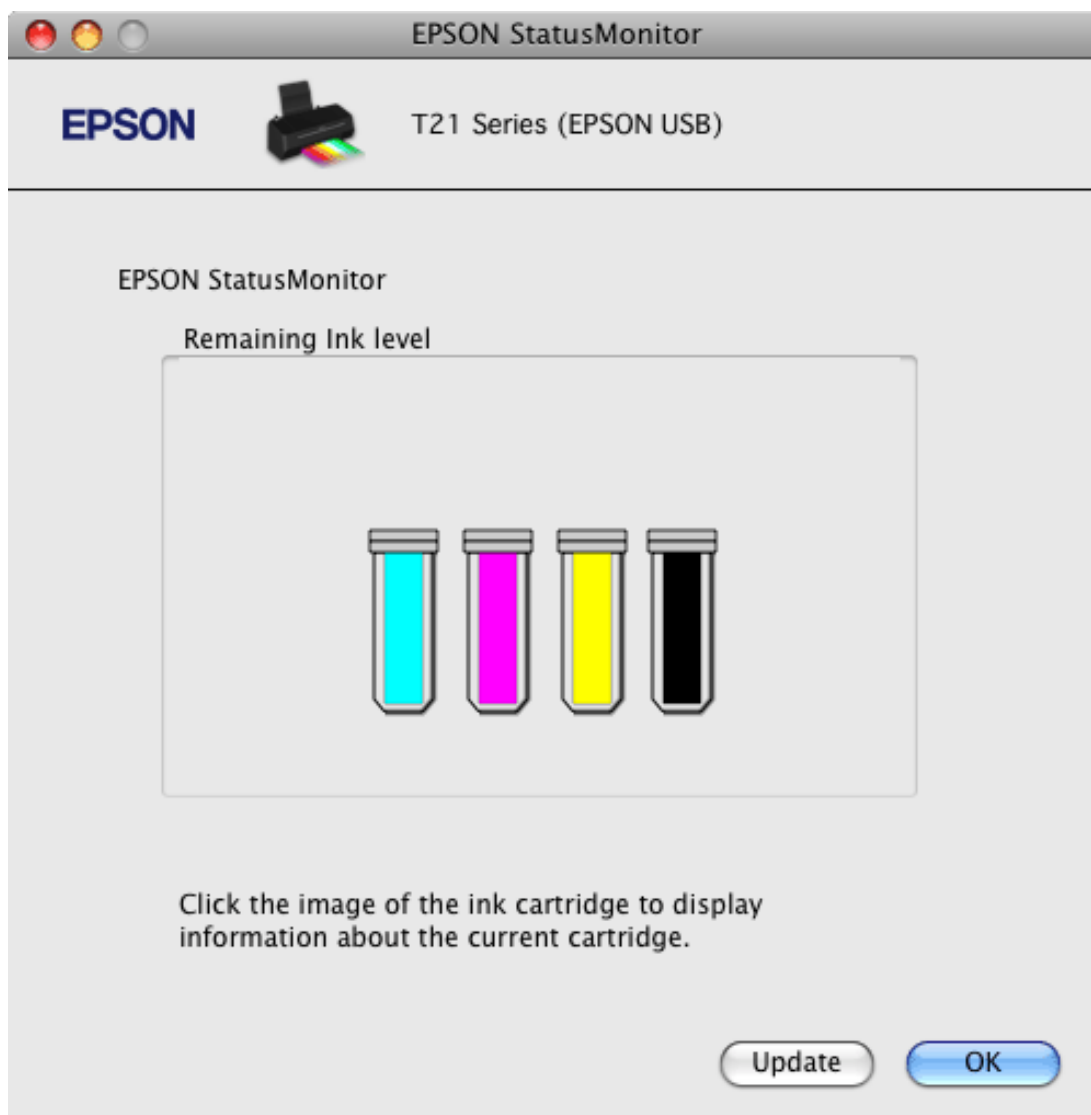

When ink is low or expended, a **How to** button appears. Click **How to**, and EPSON StatusMonitor will lead you step by step through the ink cartridge replacement procedure.

EPSON



T21 Series (EPSON USB)

Status description
Replace Cartridge
Black: 90N/73N



Actions to take

Epson recommends the genuine Epson cartridges listed above. Click the [How to] button for ink cartridge replacement instructions.

How to...

Continue

Abort





You can also use this utility to check the ink cartridge status before printing. EPSON StatusMonitor displays the ink cartridge status at the time it was opened. To update the ink cartridge status, click **Update**.

[Home](#) > [Problem Solver](#)

Print Quality Problems

- [Horizontal Banding](#)
- [Vertical Misalignment or Banding](#)
- [Incorrect or Missing Colors](#)
- [Blurry or Smearred Printout](#)

If you are having print quality problems, then compare it with the illustrations below. Click the caption under the illustration that best resembles your printout.

<p>enthalten alle Aufdruck. W 5008 "Regel</p> <p>Good sample</p>	 <p>Good sample</p>
<p>enthalten alle Aufdruck. W 5008 "Regel</p> <p>Horizontal banding</p>	<p>enthalten alle Aufdruck. W 5008 "Regel</p> <p>Vertical misalignment or banding</p>
 <p>Horizontal banding</p>	 <p>Vertical misalignment or banding</p>
 <p>Incorrect or missing colors</p>	 <p>Blurry or smeared printout</p>

Horizontal Banding



• Make sure the printable side of the paper is face up in the sheet feeder.

• Run the Head Cleaning utility to clear any clogged ink nozzles.

 See [Cleaning the Print Head](#)

• Use up ink cartridge within six months of opening vacuum package.

• Use genuine Epson ink cartridges.

• Check the  error light. If the light is flashing, replace the appropriate ink cartridge.

 See [Replacing an Ink Cartridge Before it Is Expended](#)

• Make sure the paper type selected in the printer driver is appropriate for the type of paper loaded in the printer.

 See [Selecting the Correct Paper Type](#)

[Top](#) 

Vertical Misalignment or Banding

• Make sure the printable side of the paper is face up in the sheet feeder.

• Run the Head Cleaning utility to clear any clogged ink nozzles.

 See [Cleaning the Print Head](#)

• Run the Print Head Alignment utility.

 See [Aligning the Print Head](#)

• Clear the **High Speed** check box from the Advanced window in your printer driver (Windows). See the online help for details.

• Make sure the paper type selected in the printer driver is appropriate for the type of paper loaded in the printer.

 See [Selecting the Correct Paper Type](#)

[Top](#) 

Incorrect or missing colors

• For Windows, clear **Grayscale** from Print Options in the Main window in your printer driver. For Mac OS X, change the Color setting to **Color** in Print Settings in the Print dialog box in your printer driver. See the printer driver online help for details.

- - Adjust the color settings in your application or in your printer driver settings. For Windows, check the Advanced window. For Mac OS X, check the Print Settings dialog box from the Print dialog box. See the printer driver online help for details.

- - Run the Head Cleaning utility.

 See [Cleaning the Print Head](#)

- - Check the  error light. If the light is flashing, replace the appropriate ink cartridge.

 See [Replacing an Ink Cartridge Before it is Expended](#)

- - If you have just replaced an ink cartridge, make sure the date on the box has not expired.

- - If you have not used the printer for a long time, replace the ink cartridges.

 See [Replacing an Ink Cartridge Before it is Expended](#)

Top 

Blurry or smeared printout

- - Use only paper recommended by Epson.

 See [Paper](#)

- - Try to use genuine Epson ink cartridges.

- - Make sure the printer is on a flat, stable surface that extends beyond the base in all directions. The printer will not operate properly if it is tilted.

- - Make sure your paper is not damaged, dirty, or too old.

- - Make sure your paper is dry and the printable side is facing up.

- - Make sure your paper is dry and the printable side is face down in the paper cassette.

- - If the paper is curled toward the printable side, flatten it or curl it slightly in the opposite direction.

- - Make sure the paper type selected in the printer driver is appropriate for the type of paper loaded in the printer.

 See [Selecting the Correct Paper Type](#)

- - Remove each sheet from the output tray as it is printed.

- - If you are printing on glossy media, place a support sheet (or a sheet of plain paper) beneath the stack, or load only one sheet at a time.

- Do not touch or allow anything to come into contact with the printed side of paper with a shiny finish. To handle your printouts, follow the instructions of the paper.

-

- Run the Head Cleaning utility.

-  See [Cleaning the Print Head](#)

[Top](#) 

[Home](#) > [Problem Solver](#)

Miscellaneous Printout Problems

- [Incorrect or Garbled Characters](#)
- [Incorrect Margins](#)
- [Printout Has a Slight Slant](#)
- [Inverted Image](#)
- [Blank Pages Print](#)
- [Printed Side is Smeared or Scuffed](#)
- [Printing Is Too Slow](#)

Incorrect or Garbled Characters

- - Clear any stalled print jobs from the Windows Spooler (Windows only).
[See Canceling Printing](#)
- - Turn off the printer and computer. Make sure the printer's USB cable is securely plugged in.
- - Uninstall the printer driver, then reinstall it.
[See Uninstalling the Printer Software](#)

[Top](#) 

Incorrect Margins

- - Check the margin settings in your application. Make sure that the margins are within the printable area of the page.
[See Printable area](#)
- - Make sure the printer driver settings are appropriate for the paper size you are using. For Windows, check the Main window. For Mac OS X, check the Page Setup dialog box or Print dialog box. See the printer driver online help for details.
- - Uninstall the printer driver, then reinstall it.
[See Uninstalling the Printer Software](#)

Printout Has a Slight Slant

- If **Fast Economy** is selected in **Paper & Quality Options** in the Advanced window in your printer driver (for Windows), or in **Print Quality** which is available when you select **Advanced** mode in **Print Settings** (for Mac OS X), change it to **Economy**. (**Fast Economy** is only available when the paper type is **Plain paper/Bright White Paper**.)
- Make sure that the paper is loaded into the sheet feeder correctly.

 See [Loading Paper](#)

Top 

Inverted Image

- - For Windows, clear the **Mirror Image** check box from the Page Layout window of your printer driver, or turn off the Mirror Image setting in your application.
For Mac OS X, clear the **Mirror Image** check box in **Print Settings** in the Print dialog box of your printer driver, or turn off the Mirror Image setting in your application.
For instructions, see the online help for your printer driver or for your application.

- - Uninstall the printer driver, then reinstall it.

 See [Uninstalling the Printer Software](#)

Top 

Blank Pages Print

- - Make sure the printer driver settings are appropriate for the paper size you are using.
For Windows, check the Main window.
For Mac OS X, check the Page Setup dialog box or Print dialog box.
See the printer driver online help for details.
- - For Windows, check the **Skip Blank Page** setting by clicking the **Speed & Progress** button on the Maintenance window of the printer driver.
For Mac OS X, check the **Skip Blank Page** setting in Extension Settings in the Print dialog box of your printer driver. If it is selected, blank pages in your data are not printed.
- - Uninstall the printer driver, then reinstall it.



 See [Uninstalling the Printer Software](#)

After trying one or more of these solutions, run a printer operation check to check your results.

 [Running a printer operation check](#)





Top 

Printed Side Is Smearred or Scuffed

- - If the paper is curled toward the printable side, flatten it or curl it slightly in the opposite direction.
- - Clear the **High Speed** check box in the settings from your printer driver.
For Windows, check the Advanced window.
For Mac OS X, check the Print Settings dialog box from the Print dialog box.
See the printer driver online help for details.
- - Load and eject plain paper several times.
 See [Cleaning Your Printer](#)
- - Uninstall the printer driver, then reinstall it.
 See [Uninstalling the Printer Software](#)

Top 

Printing is Too Slow





- Make sure the paper type selected in the printer driver is appropriate for the type of paper loaded in the printer.
 See [Selecting the Correct Paper Type](#)
- For Windows, clear all customized settings and select **Text** as the Quality Option from your printer driver's Main window.
 See [Accessing the printer driver for Windows](#).
For Mac OS X, clear all customized settings and select **Automatic** as the Mode and move the slider to **Speed** in the Print Settings dialog box from your printer driver's Print dialog box. See the printer driver online help for details.
 See [Accessing the printer driver for Mac OS X](#)
- Close any unnecessary applications.
- If you print continuously for an extended period, the paper may temporarily stop feeding or the print head may pause for a while. This is to slow down the printing speed and prevent the printer mechanism from overheating and being damaged. If this happens, you can continue to print, but we recommend stopping and leaving the printer for about thirty minutes with the power on. (The printer does not recover with the power off.) After you restart, the printer will print at normal speed.
- Uninstall the printer driver, then reinstall it.
 See [Uninstalling the Printer Software](#)

If you try all of the methods above and cannot solve the problem, see the following:

 [Increasing the Print Speed \(Windows only\)](#)





[Home](#) > [Problem Solver](#)

Paper Does Not Feed Correctly



-  [Paper Does not Feed](#)
-  [Multiple Pages Feed](#)
-  [The Paper Jams](#)
-  [Paper Is Improperly Loaded](#)
-  [Paper Is not Ejected fully or Is Wrinkled](#)

Paper Does not Feed

Remove the stack of paper and make sure of the following:

- The paper is not curled or creased.
- The paper is not too old. See the instructions that came with the paper for more information.
- The paper fits under the  arrow mark inside the edge guide.
- The number of sheets in the paper stack does not exceed the limit specified for the media.
 See [Loading Capacities for Epson Special Media](#)
- Paper is not jammed inside the printer. If it is, remove the jammed paper.
 See [The Paper Jams](#)
- The ink cartridges are not expended. If a cartridge is expended, replace it.
 See [Replacing an Expended Ink Cartridge](#)
- You have followed any special loading instructions that came with your paper. Load the paper again.
 See [Loading Paper](#)
- The paper does not have any binder holes.

Multiple Pages Feed

- - Make sure the paper stack fits under the  arrow mark inside the edge guide.
- - Make sure the edge guide is snug against the left edge of the paper.
- - Make sure the paper is not curled or folded. If so, flatten it or curl it slightly toward the opposite side before loading.
- - Remove the stack of paper and make sure that the paper is not too thin.
 See [Paper](#)
- - Fan the edges of the stack to separate the sheets, then reload the paper.
- - If too many copies of a file are being printed, check the Copies setting in your printer driver as follows, and also check in your application.
For Windows, check the Copies setting on the Page Layout window.
For Mac OS X 10.3.9 and 10.4.x, check the Copies setting in the Copies & Pages setting in the Print dialog box.
For Mac OS X 10.5.x, check the Copies setting in the Print dialog box.
See the printer driver online help for details.

Top 

The Paper Jams

If the paper is stuck inside the printer, open the printer cover, then remove all of the paper inside, including any torn pieces. Close the printer cover. If paper remains near the sheet feeder, gently pull it out. Then carefully reload paper and press the  maintenance button to resume printing.



Note:

If you cannot easily remove a foreign object, do not use force and do not disassemble the printer. Call Epson customer support.

 See [Contacting Technical Support](#)

If your paper jams frequently, make sure of the following:

- The paper is smooth, not curled or wrinkled.
- You are using high quality paper.
- The printable side of the paper is face up in the sheet feeder.
- The paper stack was fanned before loading.

- The paper is not loaded above the  arrow mark inside the edge guide.
- The number of sheets in the paper stack does not exceed the limit specified for that paper.
 See [Loading Capacities for Epson Special Media](#)
- The edge guide is snug against the left edge of the paper.
- The printer is on a flat, stable surface that extends beyond the base in all directions. The printer will not operate properly if it is tilted.

Top 

Paper Is Improperly Loaded

If you have loaded the paper too far into the printer, the printer cannot feed the paper correctly. Turn the printer off and gently remove the paper. Then turn the printer on and reload the paper correctly.

Top 

Paper is not ejected fully or is wrinkled

- - If the paper does not eject fully, press the  maintenance button, then open the printer cover and remove the paper. Also, check the Paper Size setting in your application or printer settings. See the online help for details.
- - If the paper is wrinkled when it comes out, it may be damp or too thin. Load a new stack of paper.

 **Note:**

Store any unused paper in its original packaging in a dry area.

[Home](#) > [Problem Solver](#)

■ The Printer Does Not Print

- [All lights Are Off](#)
- [Lights Came On and then Went Out](#)
- [Only the Power Light Is On](#)
- [The Ink Light Is Flashing or Is On After You Replace the Cartridge](#)

All Lights Are Off

- - Press the  power button to make sure the printer is on.
- - Turn off the printer and make sure that the power cord is securely plugged in.
- - Make sure that your outlet works and is not controlled by a wall switch or timer.

[Top](#) 

Lights Came On and then Went Out

The printer's voltage may not match the outlet rating. Turn off the printer and unplug it immediately. Then check the label on the back of the printer.

 **Caution:**

If the voltage does not match, DO NOT PLUG YOUR PRINTER BACK IN. Contact Epson customer support.

 See [Contacting Technical Support](#)

[Top](#) 

Only The Power Light Is On

- - Turn off the printer and the computer. Make sure the printer's USB cable is securely plugged in.
- - If you are using the USB interface, make sure your cable meets the USB 1.1 or 2.0 standards.
-

- If you are connecting the printer to your computer via a USB hub, connect the printer to the first-tier hub from your computer. If the printer driver is still not recognized on your computer, try to directly connect the printer to your computer without the USB hub.

•

- If you are connecting the printer to your computer via a USB hub, make sure the USB hub device is recognized by your computer.

•

- Turn off the printer and the computer, disconnect the printer's interface cable, then print an operation check page.

 See [Running a Printer Operation Check](#)

•

- If the check page prints correctly, make sure the printer driver and your application are installed correctly.

•

- If you are trying to print a large image, your computer may not have enough memory. Try reducing the resolution of your image or printing the image at a smaller size. You may need to install more memory in your computer.

•

- Users of Windows can clear any stalled print jobs from the Windows Spooler.

 See [Canceling Printing](#)

•

- Uninstall the printer driver, then reinstall it.

 See [Uninstalling the Printer Software](#)

N

Top 

The Ink Light Is Flashing or Us On After You Replace the Cartridge

- 1 Make sure the print head is at the ink cartridge replacement position.

 **Note:**

If the print head is at the far right position, press the  maintenance button to move it to the ink cartridge replacement position.

- 2 Remove and reinsert the ink cartridge and then continue with the ink cartridge installation.

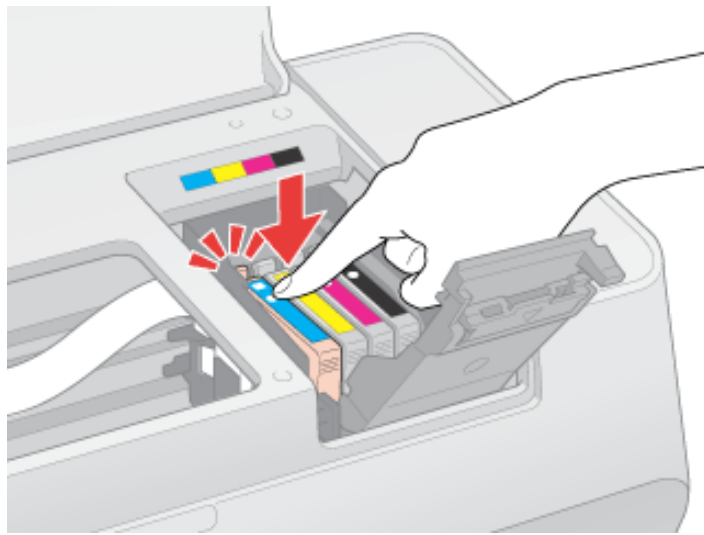

3 Close the ink cartridge cover firmly.

Home > Problem Solver

■ Increasing the Print Speed (Windows Only)

You can increase print speed by selecting certain settings in the Speed & Progress window. Click the **Speed & Progress** button on your printer driver's Maintenance window.

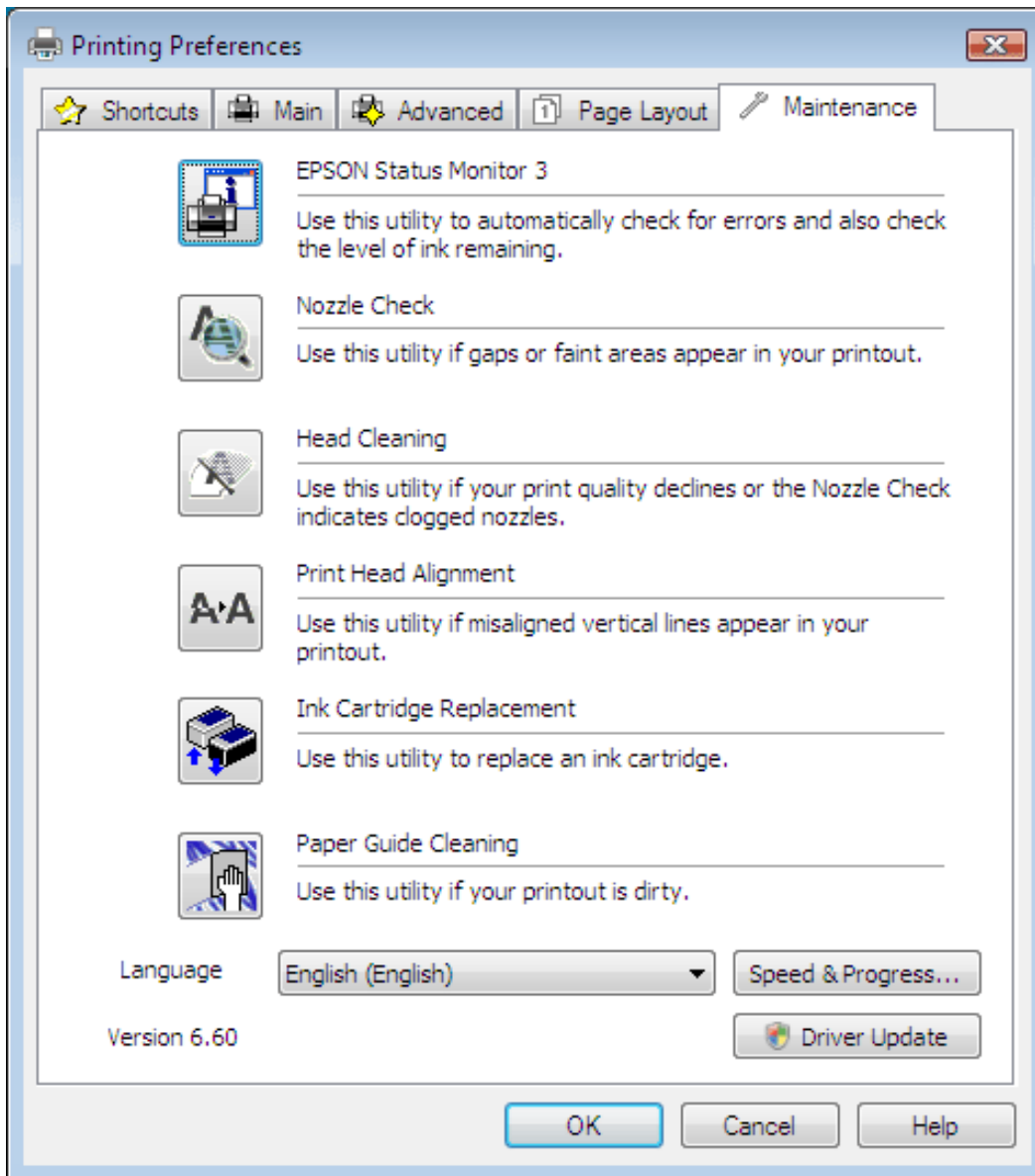

The following dialog box appears.

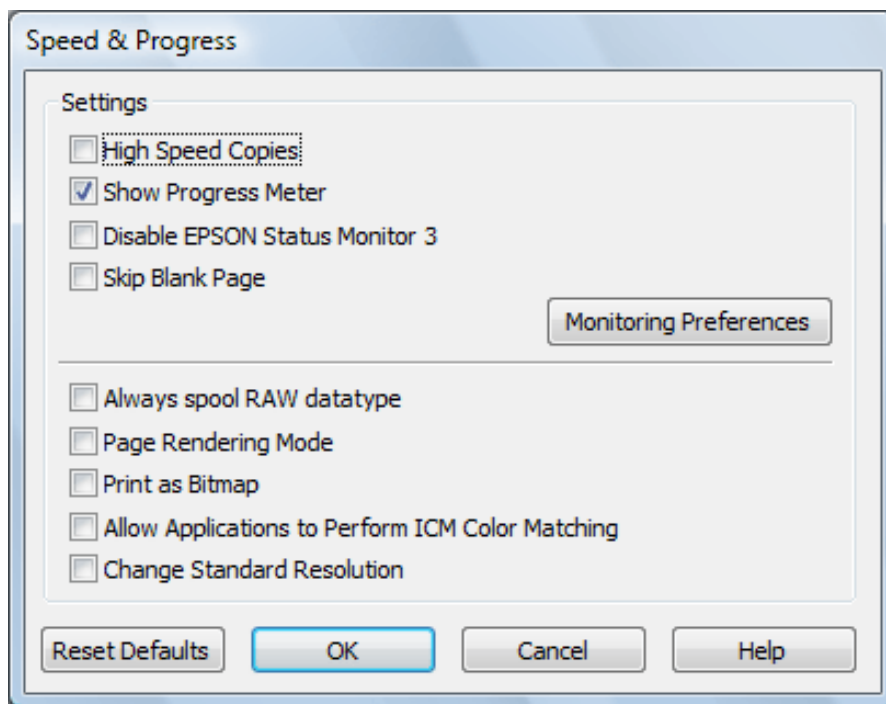

The table below lists the factors affecting print speed.

Print speed	Faster	Slower
High Speed Copies	On	Off
Always spool RAW datatype	On	Off
Page Rendering Mode	On	Off
Print as Bitmap	On	Off

For more details on each item, see the online help.

[Home](#) > [Problem Solver](#)

■ **Technical Support Web Site**

Epson's Technical Support Web Site provides help with problems that cannot be solved using the troubleshooting information in your product documentation. If you have a Web browser and can connect to the Internet, access the site at:

<http://www.latin.epson.com>

[Home](#) > [Problem Solver](#)

■ Contacting Customer Support

[Before You Contact Epson](#)[Telephone Support for Users in Latin America](#)

Before You Contact Epson

If your Epson product is not operating properly and you cannot solve the problem using the troubleshooting information in your product documentation, contact Epson's customer support services for assistance. If customer support for your area is not listed below, contact the nearest Epson sales office for referral information.

Customer support will be able to help you much more quickly if you give them the following information:

- Product serial number
(The serial number label is usually on the back of the product.)
- Product model
- Product software version
(Click **About**, **Version Info**, or similar button in the product software.)
- Brand and model of your computer
- Your computer operating system name and version
- Names and versions of the software applications you normally use with your product

[Top](#) 

Telephone Support for Users in Latin America

Argentina	(54 11) 5167-0300
Brazil	(55 11) 3956-6868
Chile	(56 2) 230-9500
Colombia	(57 1) 523-5000
Costa Rica	(50 6) 210-9555 (800) 377-6627

Mexico	
Mexico City:	(52 55) 1323-2052
Other cities:	01-800-087-1080
Peru	(51 1) 418-0210
Venezuela	(58 212) 240-1111

[Home](#) > [Product Information](#)

Printer Parts and Control Panel Functions

[Printer Parts](#)

[Control Panel](#)

Printer Parts

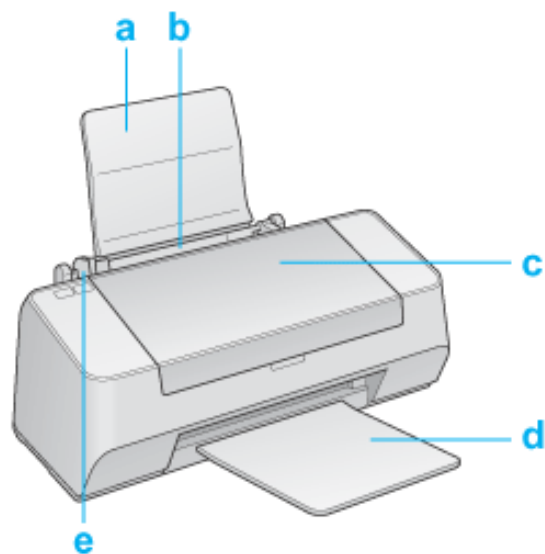

- a. Paper support: Supports the paper loaded in the sheet feeder.
- b. Sheet feeder: Holds your paper and feeds it for printing.
- c. Printer cover: Covers the printing mechanism. Open only when installing or replacing ink cartridges.
- d. Output tray: Holds the ejected paper.
- e. Edge guide: Holds your paper straight in the sheet feeder. Move the edge guide to the edge of your paper.

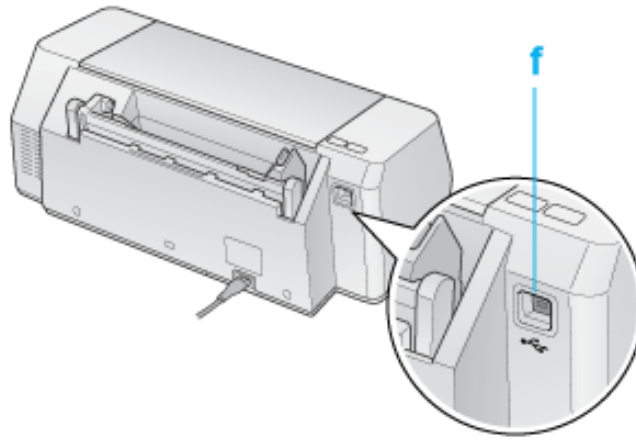

f. USB port: Connects the USB cable from your computer to the printer.

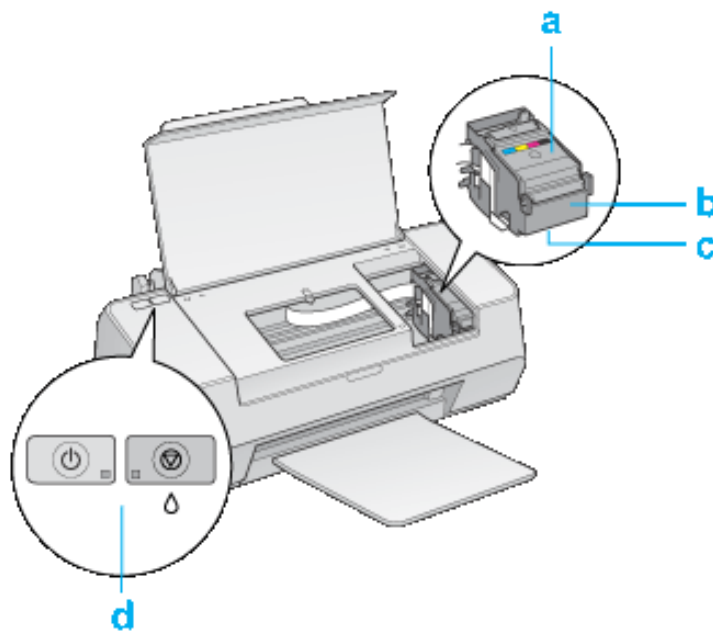



- a. Cartridge cover: Secures the ink cartridges. Open only when installing or replacing ink cartridges.
- b. Ink cartridge holder: Holds the ink cartridges.
- c. Print head: Prints ink on your paper.
- d. Control panel: Use the buttons and monitor the lights to control your printer. See the next section for details.

[Top](#)

Control Panel

Buttons

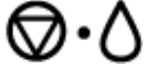
Button	Function

 power	Press to turn the printer on and off.
 maintenance	<p>Press to load paper when the printer is out of paper. Press to eject paper when paper is jammed.</p> <p>Press to resume printing after a paper out error or multiple page feed error.</p> <p>Press to cancel printing during a print job.</p> <p>Press to move the ink cartridge holder to the ink cartridge replacement position when an ink cartridge needs to be replaced.</p> <p>When an expended ink cartridge is detected, press to move the ink cartridge holder to the ink check position.</p> <p>After ink cartridge replacement, press to return the ink cartridge holder to its home position.</p> <p>When the  error light is off, press and hold for 3 seconds to clean the print head.</p>

Lights

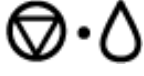
Light	Description
 power	<p>On when the printer is on.</p> <p>Flashes when the printer is receiving data, printing, replacing an ink cartridge, charging ink, or cleaning the print head.</p>
 error	<p>On when the printer is out of paper or paper is jammed.</p> <p>On when an ink cartridge is expended.</p> <p>Flashes when an ink cartridge is nearly expended.</p>

For details on the error status, see the following instructions.

 See [Error Indicators](#)

[Home](#) > [Product Information](#)

Ink and Paper

 [Ink Cartridges](#)

 [Paper](#)

Ink cartridges

You can use the following ink cartridges with this printer:

Ink cartridge color	Part numbers for Epson Stylus T21
Black	90N 73N
Cyan	73N
Magenta	73N
Yellow	73N

[Top](#) 

Paper

Epson offers specially-designed paper and other print media for all your printing needs.

 **Note:**

You can find the part numbers for the following Epson special papers on the Epson support Web site.

 See [Technical Support Web Site](#)

Paper	Size
Epson Bright White Paper	Letter (8,5 × 11 in. [21.59 × 27.94 cm])
Epson Premium Photo Paper Glossy	Letter (8,5 × 11 in. [21.59 × 27.94 cm])
	4 × 6 in. (10 × 15 cm)
	5 × 7 in. (13 × 18 cm)
	16:9 wide size (102 × 181 mm)

Epson Premium Photo Paper Semi-gloss	Letter (8,5 × 11 in. [21.59 × 27.94 cm])
	4 × 6 in. (10 × 15 cm)
Epson Ultra Premium Photo Paper Glossy	Letter (8,5 × 11 in. [21.59 × 27.94 cm])
	4 × 6 in. (10 × 15 cm)
	5 × 7 in. (13 × 18 cm)
Epson Photo Paper Glossy	Letter (8,5 × 11 in. [21.59 × 27.94 cm])
	4 × 6 in. (10 × 15 cm)
Epson Premium Presentation Paper Matte	A4 (210 × 297 mm [8.3 × 11.7 in.]) Letter (8,5 × 11 in. [21.59 × 27.94 cm])
Epson High Quality Ink Jet Paper	A4 (210 × 297 mm; 8.3 × 11.7 in)



Note:

The availability of paper varies by location.

[Home](#) > [Product Information](#)

■ System Requirements

 [Windows System Requirements](#)

 [Macintosh System Requirements](#)

Windows System Requirements

To use this printer, your system should include:

- A Microsoft Windows compatible PC with an 800 MHz or faster processor
- Microsoft Windows 2000, XP, XP Professional x64, or Windows Vista
- 256MB RAM for Windows 2000, Windows XP, and Windows XP Professional Edition (512MB recommended)
512MB RAM for Windows Vista (1GB recommended)
- 300MB free hard disk space (550MB recommended)
- 4× or faster CD-ROM drive for installing the software
- A Windows-compliant UBS port and shielded USB "AB" cable up to 2 m long. Using an improperly shielded USB cable may cause the printer to malfunction

Macintosh System Requirements

To use this printer, your system should include:

- - An Apple Macintosh with a PowerPC or Intel processor
- - Mac OS X 10.3.9, 10.4.x - 10.5.x
- - 256MB RAM (512MB recommended)

- - 300MB free hard disk space (550MB recommended)
- - 4× or faster CD-ROM drive for installing the software
- - A Macintosh-compliant UBS port and shielded USB "AB" cable up to 2 m long. Using an improperly shielded USB cable may cause the printer to malfunction

[Top](#) 

[Home](#) > [Product Information](#)

Technical Specifications

-  Paper
-  Ink Cartridges
-  Mechanical
-  Electrical
-  Environmental
-  Standards and Approvals
-  Interface

Paper



Note:

- Since the quality of any particular brand or type of paper may be changed by the manufacturer at any time, Epson cannot attest to the quality of any non-Epson brand or type of paper. Always test samples of paper stock before purchasing large quantities or printing large jobs.
- Poor quality paper may reduce print quality and cause paper jams or other problems. If you encounter problems, switch to a higher grade of paper.
- Use paper under normal conditions:
Temperature 15 to 25 °C (59 to 77 °F)
Humidity 40 to 60% RH

Single sheets:

Size	A4 (210 × 297 mm) 4 × 6 in. (10.2 × 15.2 cm) 5 × 7 in. (12.7 × 17.8 cm) A6 (105 × 148 mm) A5 (148 × 210 mm) B5 (182 × 257 mm) 3.5 × 5 in. (8.9 × 12.7 cm) 13 × 20 cm 8 × 10 in. (20.3 × 25.4 cm) 16:9 wide size (102 × 181 mm) Letter 8 1/2 × 11 in. (21.6 × 27.9 cm) Legal 8 1/2 × 14 in. (21.6 × 35.6 cm)
Paper types	Plain paper or special paper distributed by Epson
Thickness (for plain paper)	0.08 to 0.11 mm (0.003 to 0.004 in.)
Weight (for plain paper)	64 g/m ² (17 lb) to 90 g/m ² (24 lb)

Envelopes:

Size	Envelope #10 4 1/8 × 9 1/2 in. Envelope DL 110 × 220 mm Envelope C6 114 × 162 mm
Paper types	Plain paper
Weight	75 g/m ² (20 lb) to 90 g/m ² (24 lb)

Printable Area

Highlighted portions show printable area.

Single sheets:

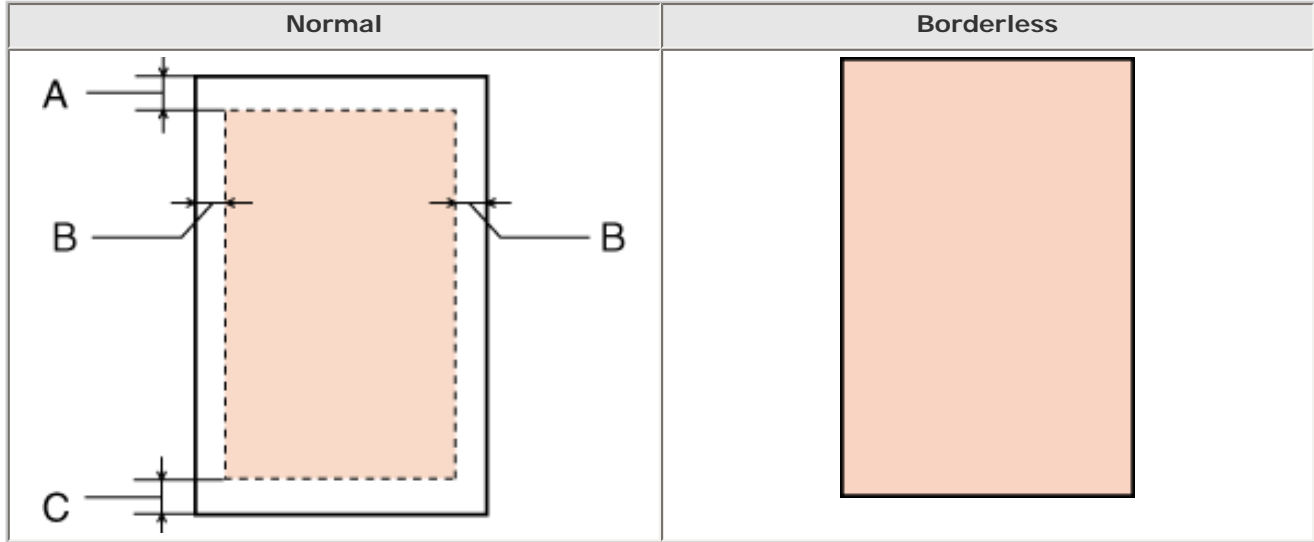

Envelopes:

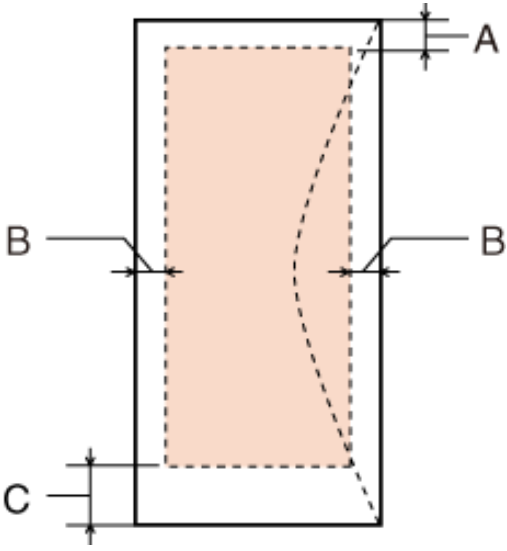

	Minimum margin	
Media type	Single sheets	Envelopes
A	3.0 mm (0.12 in.)	3.0 mm (0.12 in.)
B	3.0 mm (0.12 in.)	5.0 mm (0.20 in.)
C	3.0 mm (0.12 in.)	20 mm (0.78 in.)

 **Note:**

Depending on the type of paper, print quality may decline in the top and bottom areas of the printout, or the area may be smeared.

Top 

Ink Cartridges

Color	Yellow (73N), Magenta (73N), Cyan (73N), Black (90N or 73N)
Cartridge life	Use within 6 months of opening the package.
Temperature	Storage: -20 to 40 °C (-4 to 104 °F) 1 month at 40 °C (104 °F) Freezing: * -16 °C (3.2 °F)

* Ink thaws and is usable after approximately 3 hours at 25 °C (77 °F).

 **Caution:**

- Epson recommends the use of genuine Epson ink cartridges. Epson cannot guarantee the quality or reliability of non-genuine ink. The use of non-genuine ink may cause damage that is not covered by Epson's warranties, and under certain circumstances, may cause erratic printer behavior. Information about non-genuine ink levels may not be displayed.
- Use the ink cartridge before the date printed on its package.

 **Note:**

- The ink cartridges packaged with your printer are partly used during initial setup. In order to produce high quality printouts, the print head in your printer will be fully charged with ink. This one-off process consumes a quantity of ink and therefore these cartridges may print fewer pages compared to subsequent ink cartridges.
- Quoted yields may vary depending on the images that you are printing, the paper type that you are using, the frequency of your prints and environmental conditions such as temperature.
- To ensure you receive premium print quality and to help protect your print head, a variable ink safety reserve remains in the cartridge when your printer indicates to replace the cartridge. The yields quoted for you do not include this reserve.
- Although the ink cartridges may contain recycled materials, this does not effect product function or performance.

Top 

Mechanical

Paper path	Sheet feeder, top entry
Sheet feeder capacity	About 80 sheets at 90 g/m ² (24 lb) paper*

Dimensions	Storage Width: 435 mm (17.3 inches) Depth: 219 mm (8.6 inches) Height: 165 mm (6.5 inches)
	Printing Width: 435 mm (17.3 inches) Depth: 418 mm (16.5 inches) Height: 289 mm (11.4 inches)
Weight	Approx. 2.8 kg (6.16 lb) without the ink cartridges

* For Legal and User Defined sizes, load one sheet at a time.

[Top](#) 

Electrical

		100-120 V Model	220-240 V Model
Input voltage range		90 to 132 V	198 to 264 V
Rated frequency range		50 to 60 Hz	
Input frequency range		49.5 to 60.5 Hz	
Rated current		0.4 A	0.2 A
Power consumption	Printing	Approx. 11 W (ISO/IEC24712)	Approx. 11 W (ISO/IEC24712)
	Ready mode	Approx. 3.0 W	Approx. 3.5 W
	Sleep mode	Approx. 2.5 W	Approx. 3.0 W
	Power off	Approx. 0.2 W	Approx. 0.4 W

Note:

Check the label on the back of the printer for its voltage.

[Top](#) 

Environmental

Temperature	Operation: 10 to 35 °C (50 to 95 °F) Storage: -20 to 40 °C (-4 to 104 °F) 1 month at 40 °C (104 °F)
Humidity	Operation: * 20 to 80% RH Storage: * 5 to 85% RH

* Without condensation

[Top](#) 

Standards and approvals

European model:

Low voltage directive 2006/95/EC	EN60950-1
EMC directive 2004/108/EC	EN55022 Class B EN61000-3-2 EN61000-3-3 EN55024

[Top](#) 

Interface

USB 1.1 (Device Class for computers)
